

Gas Forced Air Furnace Systems

Forced air natural gas heating remains the most popular method of heating the majority of new homes in Manitoba.

Designed and installed properly, forced air gas heating remains one of the best choices for consumers to heat their new homes. It allows for easy interconnection with an HRV system, central air conditioning, and a central air filtration device. As it is one of the most frequently installed heating systems, it is dealt with in significant detail later in this section.

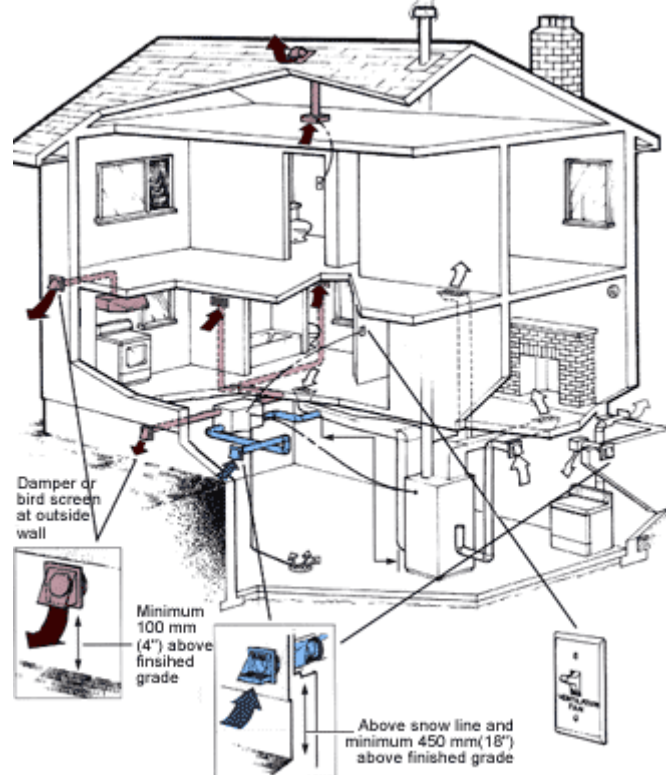

Propane Fired Forced Air Furnace Systems

Propane fired furnaces operate in almost every respect, similar to natural gas forced air furnace systems. They are popular in rural and northern Manitoba - in locations that are not serviced by natural gas in their communities.

Instead of having a main natural gas line running down your street and into your home, a propane storage tank is installed above grade on your property somewhere outside the house and is piped directly into the furnace. A local supply truck attends to the house to refill the tank as required.

Wood / Electric Forced Air Furnace Systems

As the name implies, combination wood burning/electric forced air furnaces can use either wood or electricity as a fuel source for heat. These furnaces combine a conventional wood-burning firebox with electric resistance coils above. A fan moves air over the firebox to absorb heat and distribute it around the house through conventional air distribution ductwork. Filled full of wood, these furnaces can burn a number of hours without attention to provide adequate heat for the house. Once the fire burns down and is not able to provide adequate heat, the electric resistance coils turn on to supply heat for the system.

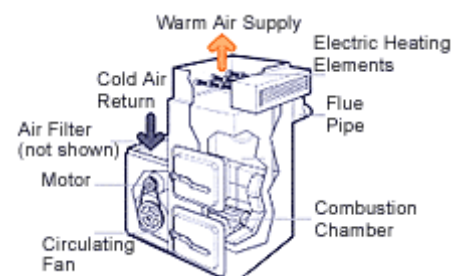

Depending on homeowner dedication to maintenance of the wood burning cycle, this heating system can significantly reduce consumption of electricity for heating the house and save money. The economic benefit analysis though depends on whether the wood is purchased or not, at what price the

wood is purchased, the type of wood used and the value the homeowner places on their time and effort.

As most wood/electric furnaces are manufactured locally on a small-scale basis, none of the models seem to have been tested and rated for combustion efficiency. Their combustion efficiency process may be as low as 50%.

If a homeowner has to purchase wood at about \$150 a cord, considering the heat content of various wood species, it is almost as costly to burn wood for heat as heating with electricity and therefore, makes little economic sense. If wood can be purchased at a lower cost or obtained for free and the homeowner enjoys the daily work entailed in burning wood, then this system is worth considering for your new house.

The Basic Requirements for an Effective Forced Air Heating System

One of the most important but most over looked components of any heating system is the design. Before the contract is signed for the supply and installation of the forced air gas heating system, a homeowner is best served by having a proper design completed.

If all system components and details are clearly laid out to all subcontractors to tender on because they were designed beforehand, chances are better that a high quality furnace and ductwork distribution system will be priced out and installed. If, as is the industry norm, an architectural set of floor plans is given out to mechanical subtrades for them to select components and design the heating system for pricing, a "lowest price mentality" may drive the process. Components, materials, and workmanship may be reduced to meet General Contractor and consumer demands for a low price and you may not end up with a heating system that meets your expectations.

Selection of a Gas Furnace

There are currently three basic types of gas fired furnaces to select from within the Manitoba market.

- Mid-efficiency furnaces burn gas at about 80% efficiency. This furnace type is generally vented up a chimney and uses room air for the combustion process. The gas burner is usually a conventional, naturally aspirating type but does not have a continuous pilot light.

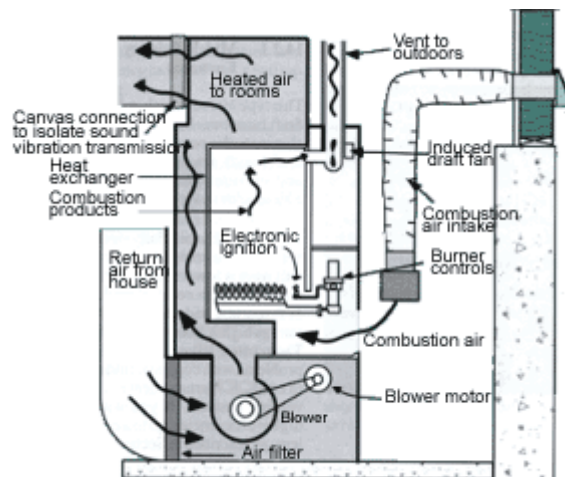

- High-efficiency condensing furnaces burn gas at about 90% - 92% efficiency. This furnace type is vented out the sidewall of the home through piping that both brings in combustion air and exhausts the products of combustion. Because the combustion efficiency of this furnace goes beyond 80%, the additional heat removed from the combustion gas cools it to a point where water vapour condenses out within the system. Because the condensate is corrosive, most of the heat exchangers are made out of higher-grade stainless steel.

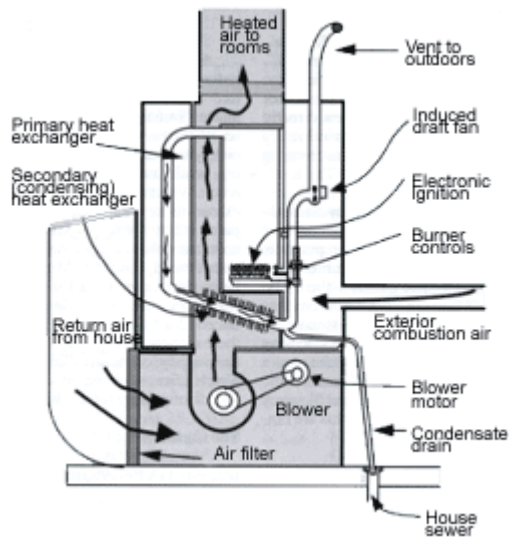

- The most recent addition to the market is the high-efficiency condensing furnace with a two-stage gas burner, which takes the seasonal efficiency rating up to around 94%. The burner initially comes on at about 40% - 60% of its capacity, which suits cooler temperature spring and fall conditions. If the initial stage cannot warm the house, the burner upgrades to 100% capacity to meet colder winter conditions. This furnace is generally associated with an energy efficient DC blower motor to save on electrical consumption.

Installation

The location of the furnace should take into account ease of access for future maintenance and eventual replacement at some date. A more central location makes for moving air through shorter duct runs to all areas of the house.

Duct runs should be in accordance with the design and completed as smooth as possible with minimum use of elbows and fitting. Each 90-degree elbow adds as much resistance to airflow as 10 feet of straight duct.

It is a good idea to seal all ductwork joints with paint on duct sealer or foil type tape. Note that "duct tape" (the gray material type) is not a very good product for sealing heating ducts. Over time, under heat, the solvents disburse from the glue and the tape falls off. Sealing ducts insures that air gets to its intended location rather than leaking out along the way.

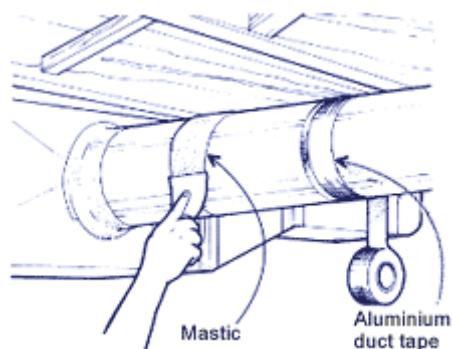

Balancing dampers should be installed in all branch duct runs, ideally just after the main trunk. Balancing dampers allow for the adjustment of airflow to all areas of the house. Dampers are especially important in two story homes, which need to adjust airflow volumes between the main and second floor each winter and summer for the different requirements of heating and air conditioning.

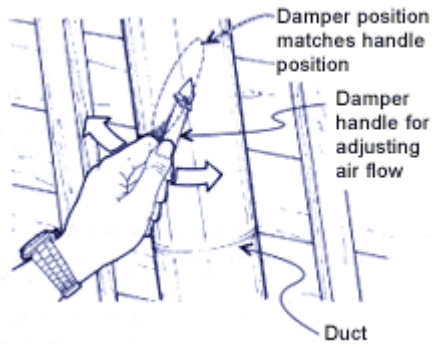

Commissioning

Commissioning, or confirmation of the correct operation of the heating and ductwork distribution system in accordance with the design, is rarely done on new homes in Manitoba. As most homeowners do not realize the value of commissioning, they're not willing to pay their contractor for it.

A short system commissioning procedure will identify obvious problems for correction before they become a comfort complaint requiring a service call.

Once the entire system is installed and operational, a system of checks and adjustments needs to be done to bring the installed heating and distribution system into compliance with the original design. HRAI offers a training course for commissioning residential heating systems in which contractors learn all the detailed quality checking procedures from confirming gas pressures to balancing air flows.



Commissioning can be as simple as measuring air flows on a room by room basis and adjusting them to meet the design requirements. If the design calls for 25 cfm to be delivered by the bedroom floor grill and it measured to only be delivering 10 cfm, it will result in a cold bedroom in the winter months. One of the simplest methods of measuring relative air flow is with a garbage bag. By holding a garbage bag over an air supply grill and timing how long it takes to fill up with air, a rough approximation of air flow can be calculated. Experience has shown that major problems are quickly identified for correction when one supply grill fills the bag in three seconds and the next takes 12 seconds.

Reference:

http://www.r2000manitoba.com/heating_heat_dist5.shtml