

Power Factor— The Basics

OK. I've heard a lot about this power factor stuff. What exactly is it?

We hope to give you an easy explanation of what power factor is, and to answer the following most asked questions:

Question #1: **What is Power Factor?**

Question #2: **What Causes Low Power Factor?**

Question #3: **Why Should I Improve My Power Factor?**

Question #4: **How Do I Correct (Improve) My Power Factor?**

Question #5: **How Long Will It Take My Investment in Power Factor Correction to Pay for Itself?**

Question #6: **What is the Next Step?**

Question #1: What is Power Factor?

Super. I'm ready to find out what power factor is.

To understand power factor, we'll first start with the definition of some basic terms:

KW is Working Power (also called Actual Power or Active Power or Real Power).
It is the power that actually powers the equipment and performs useful work.

KVAR is Reactive Power.
It is the power that magnetic equipment (transformer, motor and relay) needs to produce the magnetizing flux.

KVA is Apparent Power.
It is the "vectorial summation" of KVAR and KW.

Let's look at a simple analogy in order to better understand these terms....

Let's say you are at the ballpark and it is a really hot day. You order up a mug of your favorite brewsky. The thirst-quenching portion of your beer is represented by **KW** (Figure 1).

Unfortunately, life isn't perfect. Along with your ale comes a little bit of foam. (And let's face it...that foam just doesn't quench your thirst.) This foam is represented by **KVAR**.

The total contents of your mug, **KVA**, is this summation of KW (the beer) and KVAR (the foam).

The Beer Analogy

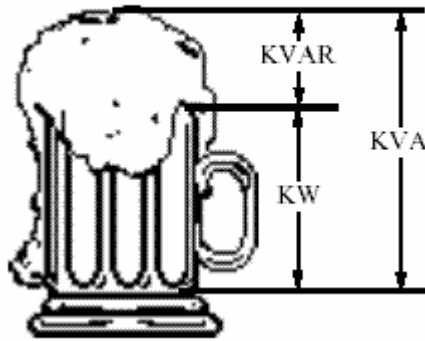

Figure 1

So, now that we understand some basic terms, we are ready to learn about power factor:

Power Factor (P.F.) is the ratio of Working Power to Apparent Power.

$$\text{P.F.} = \frac{\text{KW}}{\text{KVA}}$$

Looking at our beer mug analogy above, power factor would be the ratio of beer (KW) to beer plus foam (KVA).

$$\text{P.F.} = \frac{\text{KW}}{\text{KW} + \text{KVAR}}$$

$$. = \frac{\text{Beer}}{\text{Beer} + \text{Foam}}$$

Thus, for a given KVA:

- The more foam you have (the higher the percentage of KVAR), the lower your ratio of KW (beer) to KVA (beer plus foam). Thus, the lower your power factor.
- The less foam you have (the lower the percentage of KVAR), the higher your ratio of KW (beer) to KVA (beer plus foam). In fact, as your foam (or KVAR) approaches zero, your power factor approaches 1.0.

Our beer mug analogy is a bit simplistic. In reality, when we calculate KVA, we must determine the “vectorial summation” of KVAR and KW. Therefore, we must go one step further and look at the angle between these vectors.

Let’s look at another analogy

Mac here is dragging a heavy load (Figure 2). Mac’s Working Power (or Actual Power) in the forward direction, where he most wants his load to travel, is **KW**.

Unfortunately, Mac can’t drag his load on a perfect horizontal (he would get a tremendous backache), so his shoulder height adds a little Reactive Power, or **KVAR**.

The Apparent Power Mac is dragging, **KVA**, is this “vectorial summation” of KVAR and KW.

Dragging Mac's BMI Analogy

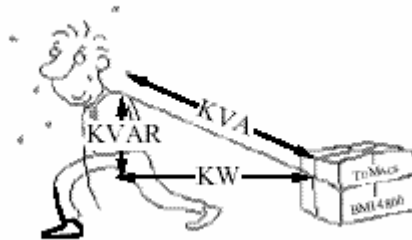
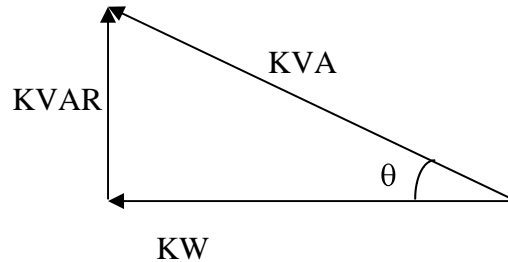

Figure 2

The “Power Triangle” (Figure 3) illustrates this relationship between KW, KVA, KVAR, and Power Factor:

The Power Triangle



$$\text{P.F.} = \frac{\text{KW}}{\text{KVA}} = \cos \theta$$

$$\frac{\text{KVAR}}{\text{KVA}} = \sin \theta$$

$$\text{KVA} = \sqrt{\text{KW}^2 + \text{KVAR}^2} = \text{KV} * \text{I} * \sqrt{3}$$

Figure 3

Note that...in an ideal world...looking at the beer mug analogy:

- KVAR would be very small (foam would be approaching zero)
- KW and KVA would be almost equal (more beer; less foam)

Similarly...in an ideal world...looking at Mac's heavy load analogy:

- KVAR would be very small (approaching zero)
- KW and KVA would be almost equal (Mac wouldn't have to waste any power along his body height)
- The angle θ (formed between KW and KVA) would approach zero
- Cosine θ would then approach one
- Power Factor would approach one

So....

In order to have an "efficient" system (whether it is the beer mug or Mac dragging a heavy load), we want power factor to be as close to 1.0 as possible.

Sometimes, however, our electrical distribution has a power factor much less than 1.0. Next, we'll see what causes this.

Question #2: What Causes Low Power Factor?

Great. I now understand what power factor is. But I've been told mine is low. What did I do to cause this?

Since power factor is defined as the ratio of KW to KVA, we see that low power factor results when KW is small in relation to KVA. Remembering our beer mug analogy, this would occur when KVAR (foam, or Mac's shoulder height) is large.

What causes a large KVAR in a system? The answer is...**inductive loads**.

Inductive loads (which are sources of Reactive Power) include:

- ❑ **Transformers**
- ❑ **Induction motors**
- ❑ **Induction generators (wind mill generators)**
- ❑ **High intensity discharge (HID) lighting**

These inductive loads constitute a major portion of the power consumed in industrial complexes.

Reactive power (KVAR) required by inductive loads increases the amount of apparent power (KVA) in your distribution system (Figure 4). This increase in reactive and apparent power results in a larger angle θ (measured between KW and KVA). Recall that, as θ increases, cosine θ (or power factor) decreases.

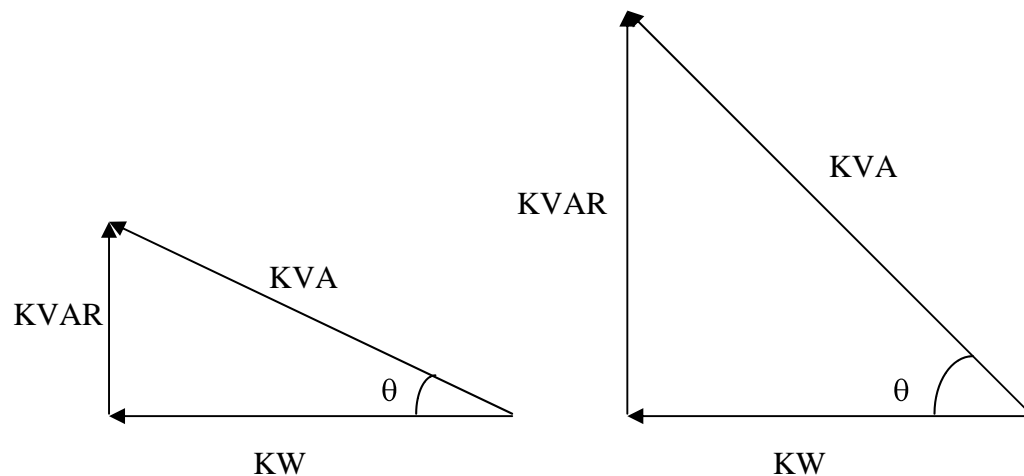

Figure 4

So, inductive loads (with large KVAR) result in low power factor.

Question #3:

Why Should I Improve My Power Factor?

Okay. So I've got inductive loads at my facility that are causing my power factor to be low. Why should I want to improve it?

You want to improve your power factor for several different reasons. Some of the benefits of improving your power factor include:

1) **Lower utility fees** by:

a. Reducing peak KW billing demand

Recall that inductive loads, which require reactive power, caused your low power factor. This increase in required reactive power (KVAR) causes an increase in required apparent power (KVA), which is what the utility is supplying.

So, a facility's low power factor causes the utility to have to increase its generation and transmission capacity in order to handle this extra demand.

By lowering your power factor, you use less KVAR. This results in less KW, which equates to a dollar savings from the utility.

b. Eliminating the power factor penalty

Utilities usually charge customers an additional fee when their power factor is less than 0.95. (In fact, some utilities are not obligated to deliver electricity to their customer at any time the customer's power factor falls below 0.85.) Thus, you can avoid this additional fee by increasing your power factor.

2) **Increased system capacity and reduced system losses** in your electrical system

By adding capacitors (KVAR generators) to the system, the power factor is improved and the KW capacity of the system is increased.

For example, a 1,000 KVA transformer with an 80% power factor provides 800 KW (600 KVAR) of power to the main bus.

$$1000 \text{ KVA} = \sqrt{(800 \text{ KW})^2 + (? \text{ KVAR})^2}$$

$$\text{KVAR} = 600$$

By increasing the power factor to 90%, more KW can be supplied for the same amount of KVA.

$$1000 \text{ KVA} = \sqrt{(900 \text{ KW})^2 + (? \text{ KVAR})^2}$$

$$\text{KVAR} = 436$$

The KW capacity of the system increases to 900 KW and the utility supplies only 436 KVAR.

Uncorrected power factor causes power system losses in your distribution system. By improving your power factor, these losses can be reduced. With the current rise in the cost of energy, increased facility efficiency is very desirable. And with lower system losses, you are also able to add additional load to your system.

3) Increased voltage level in your electrical system and cooler, more efficient motors

As mentioned above, uncorrected power factor causes power system losses in your distribution system. As power losses increase, you may experience voltage drops. Excessive voltage drops can cause overheating and premature failure of motors and other inductive equipment.

So, by raising your power factor, you will minimize these voltage drops along feeder cables and avoid related problems. Your motors will run cooler and be more efficient, with a slight increase in capacity and starting torque.

Question #4

How Do I Correct (Improve) My Power Factor?

All right. You've convinced me. I sure would like to save some money on my power bill and extend the life of my motors. But how do I go about improving (i.e., increasing) my power factor?

We have seen that **sources of Reactive Power** (inductive loads) decrease power factor:

- ❑ **Transformers**
- ❑ **Induction motors**
- ❑ **Induction generators (wind mill generators)**
- ❑ **High intensity discharge (HID) lighting**

Similarly, **consumers of Reactive Power** increase power factor:

- ❑ **Capacitors**
- ❑ **Synchronous generators (utility and emergency)**
- ❑ **Synchronous motors**

Thus, it comes as no surprise that one way to increase power factor is to add capacitors to the system. This--and other ways of increasing power factor--are listed below:

1) **Installing capacitors (KVAR Generators)**

Installing capacitors decreases the magnitude of reactive power (KVAR or foam), thus increasing your power factor.

Here is how it works (Figure 5)...

Reactive power (KVARs), caused by inductive loads, always acts at a 90-degree angle to working power (KW).

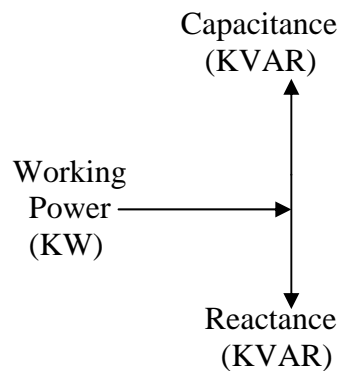

Figure 5

Inductance and capacitance react 180 degrees to each other. Capacitors store KVARs and release energy opposing the reactive energy caused by the inductor.

The presence of both a capacitor and inductor in the same circuit results in the continuous alternating transfer of energy between the two.

Thus, when the circuit is balanced, all the energy released by the inductor is absorbed by the capacitor.

Following is an example of how a capacitor cancels out the effect of an inductive load....

2) Minimizing operation of idling or lightly loaded motors.

We already talked about the fact that low power factor is caused by the presence of induction motors. But, more specifically, low power factor is caused by running induction motors lightly loaded.

3) Avoiding operation of equipment above its rated voltage.

4) Replacing standard motors as they burn out with energy-efficient motors.

Even with energy-efficient motors, power factor is significantly affected by variations in load. A motor must be operated near its rated load in order to realize the benefits of a high power factor design.

Question #5

How Long Will It Take my Investment in Power Factor Correction to Pay for Itself?

Super, I've learned that by installing capacitors at my facility, I can improve my power factor. But buying capacitors costs money. How long will it take for the reduction in my power bill to pay for the cost of the capacitors?

A calculation can be run to determine when this payoff will be. As an example, assume that a portion of your facility can be modeled as in Figure 6 below. Your current power factor is 0.65.

Following are the parameters for your original system:

- 163 KW load
- 730 hours per month
- 480 Volt, 3 phase service
- 5% system losses
- Load PF = 65%
- PSE Rate Schedule:
 - Energy Rate = \$4.08 per KWH
 - Demand Charge = \$2.16 per KW
 - PF Penalty = \$0.15 per KVARH

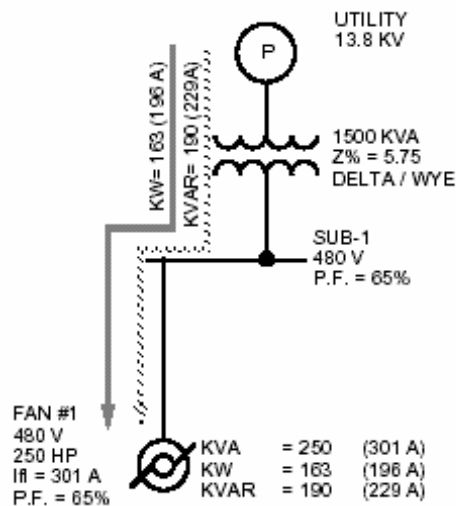

Figure 6

We'll calculate the total amount the utility charges you every month as follows:

First, we'll calculate your **energy usage**:

$$163 \text{ KW} \times 730 \text{ Hours/Month} \times \$4.08/\text{KWH} = \$4,854.79/\text{Month}$$

Next, we'll calculate your **demand charge**:

$$163 \text{ KW} \times \$2.16/\text{KW} = \$352.08/\text{Month}$$

Finally, we'll calculate your **Power Factor Penalty**:

$$190 \text{ KVAR} \times 730 \text{ Hours/Month} \times \$0.15/\text{KVARH} = \$208/\text{Month}$$

Now, let's say that you decide to install a capacitor bank (Figure 7). The 190 KVAR from the capacitor cancels out the 190 KVAR from the inductive motor. Your power factor is now 1.0.

Following are your parameters for your system with capacitors:

- Corrected PF = 1.0

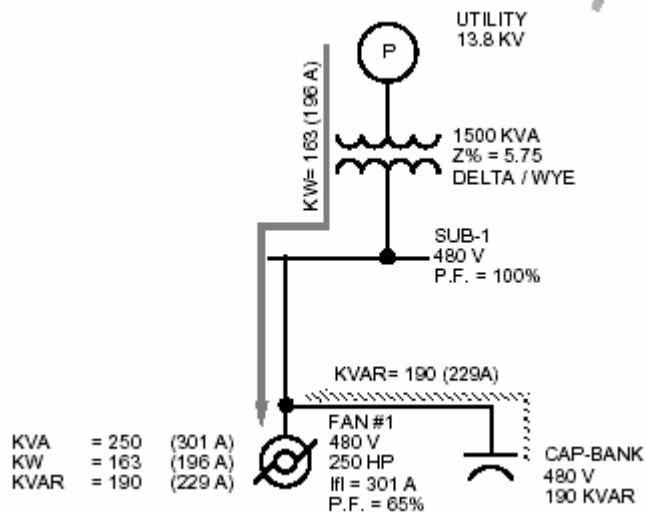

Figure 7

You can calculate your loss reduction:

$$\text{Loss Reduction} = 1 - (0.65^2 / 1.00^2) = 0.58$$

Therefore, your system loss reduction will be as follows:

$$0.58 \times 0.05 \text{ (losses)} = 0.029 \text{ System Loss Reduction}$$

Your total KW load will be reduced as follows:

$$163 \text{ KW} \times 0.029 = 4.7 \text{ KW}$$

Now we can calculate your savings in **energy usage**:

$$4.7 \text{ KW} \times 730 \text{ Hours/Month} \times \$4.08/\text{KWH} = \$141.00/\text{Month}$$

Next, we'll calculate your savings in **demand charge**:

$$4.7 \text{ KW} \times \$2.16/\text{KW} = \$10.15/\text{Month}$$

Finally, remember that your **Power Factor Penalty** is zero.

Let's calculate how long it will take for this capacitor bank to pay for itself.

- Capacitor Cost = \$30.00/KVAR

Your savings per month are as follows:

| | | |
|---|-----------------|-------------------|
| ◆ | \$141.00 | Energy Usage |
| ◆ | \$ 10.15 | Demand Charge |
| ◆ | <u>\$208.00</u> | PF Penalty Charge |
| | \$359.15 | Total |

Your payback will be at the following time:

$$\$30.00/\text{KVAR} \times 190 \text{ KVAR}/\$359/\text{Month} = 16 \text{ Months}$$

Installation of your capacitors will pay for themselves in 16 months.

Question #6

What is the next step?

Terrific. I think I should take a look at the power factor at my facility and see what I can do to improve it. So what do I do next?

Power Systems Engineering can assist you in determining the optimum power factor correction for your facility. We can also help you to correctly locate and provide tips on installing capacitors in your electrical distribution system.

Feel free to call us, fax us, e-mail us, and continue to check us out on the web. We would be happy to talk to you about your specific application.

Telephone: (253) 639-8535
Fax: (253) 639-8685
E-mail: fuhr@powerstudies.com
Web: www.powerstudies.com