



ITC Maurya, New Delhi

Acknowledged as the preferred residence of visiting heads of state and global business leaders for over 25 years – ITC Maurya epitomizes the luxury hotel experience. The Hotel has started its operation in the year 1977.

The Maurya is a luxury business hotel with modern and contemporary facilities, located in the heart of the exclusive Diplomatic Enclave, approximately 14 k.m. (25 min) from the International Airport; offering a superb view of Delhi's green belt – the forested ridge.

Named after the Mauryan Dynasty of the 3rd century, B.C. it is an imposing structure of superb luxury with 440 Rooms, inclusive of 29 uniquely designed Suites. The striking pyramidal architecture of the hotel inspired by the Buddhist stupas and ambiance are a tribute to the age of the great Mauryan Dynasty, which gave Indian history its golden era. The hotel offers a bouquet of room categories; the **Executive Club**, pioneers a tradition in corporate hospitality, the **Towers**, presents eight luxurious floors of elegance and tranquility, the **Luxury Room**, Combines the best of luxury, space and service standards & the **ITC One**, our premium room category offers magnificent decor, impeccable service & the latest in modern conveniences / amenities. Behind the lavishness is a crisp efficiency and a deep understanding of the needs of *“The discerning Global Traveller”*. *The hotel has 07 food and beverage outlets in the building.*



The total area of the hotel is 6 acres; air-conditioned area being 41283 sq meters and total built up area 55044 sq meters. Temperature maintained through out the air-conditioned space is 22 degree. The connected load of the hotel is approximately 4657 KW.

AWARDS & ACCOLADES

- Energy Conservation Award 2006-07 awarded by BEE Government of India.
- National Tourism Award 2006-07 – Best Eco-Friendly Hotel Awarded by National tourism Department Government of India
- ITC Hotels awarded the PATA green Gold award 2005 in Corp. Environment category.
- **“Greentech Safety Platinum Award”** for the year 2003-04 amongst ‘Services Sector’ for outstanding achievement in EHS Management, from the **Greentech Foundation**.
- **“Greentech Safety Gold Award”** for the year 2002-03 amongst ‘Services Sector’ for excellence in EHS Management, from the **Greentech Foundation**.
- **“Environment Champion Hotel of the Year 2002”** (among Large Hotels) across the country by the **Federation of Hotel & Restaurant Association of India (FHRAI)**.
- IH & RA Environment Award 2002 (Corp. Category) - Runners Up, for: **"Energy and Indoor Air Quality in Hotels & Restaurants"**.
- **Golden Peacock Environment Award 2001** (Category : Large Service Industry) from **World Environment Foundation, U.K.**
- **Best Green Hotel** for the year **2000** from **Pacific Asia Travel Writers Association**, World Travel Market, London, U.K.
- **Environment Good Practices in Hotels-1997** Case study: Maurya Sheraton Published by International Hotels and Restaurant Association (IH&RA).
- **Green Hotelier and Most Eco Friendly Hotel** for the year 1997 from **International Hotels & Restaurant Association (IH&RA)**.
- **Corporate Award for the Most Eco-friendly Hotel** : across the globe, for the year **1997** and **2000** from **IH&RA**.

Energy consumption trends for ITC Maurya

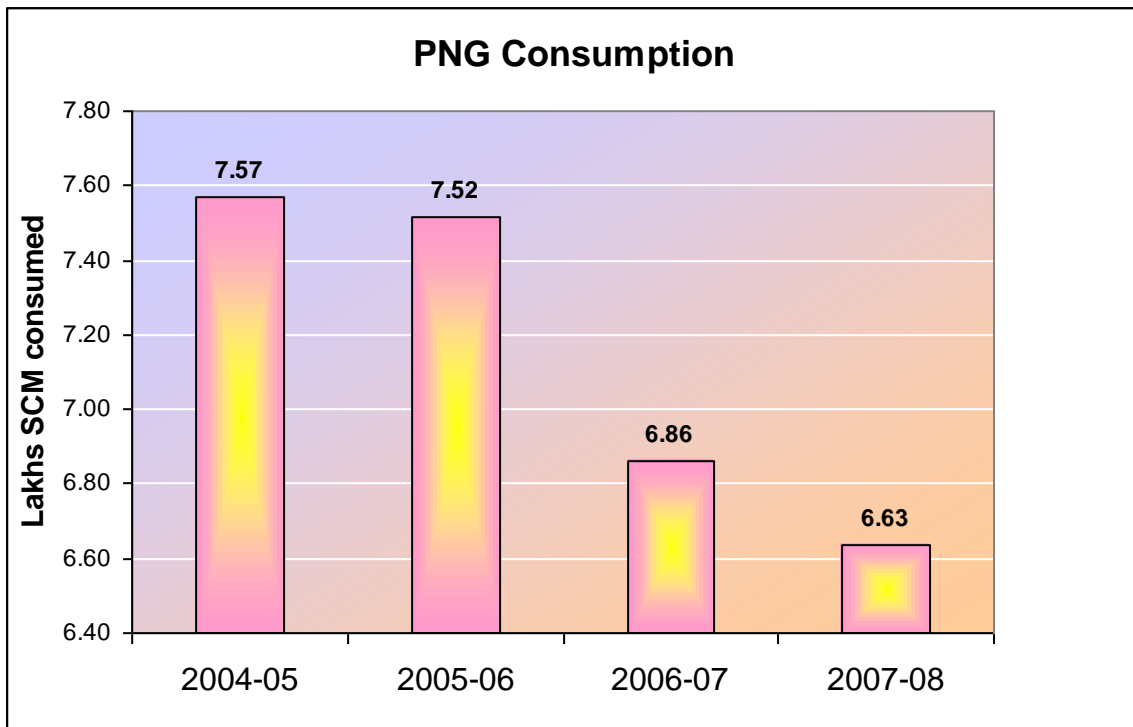
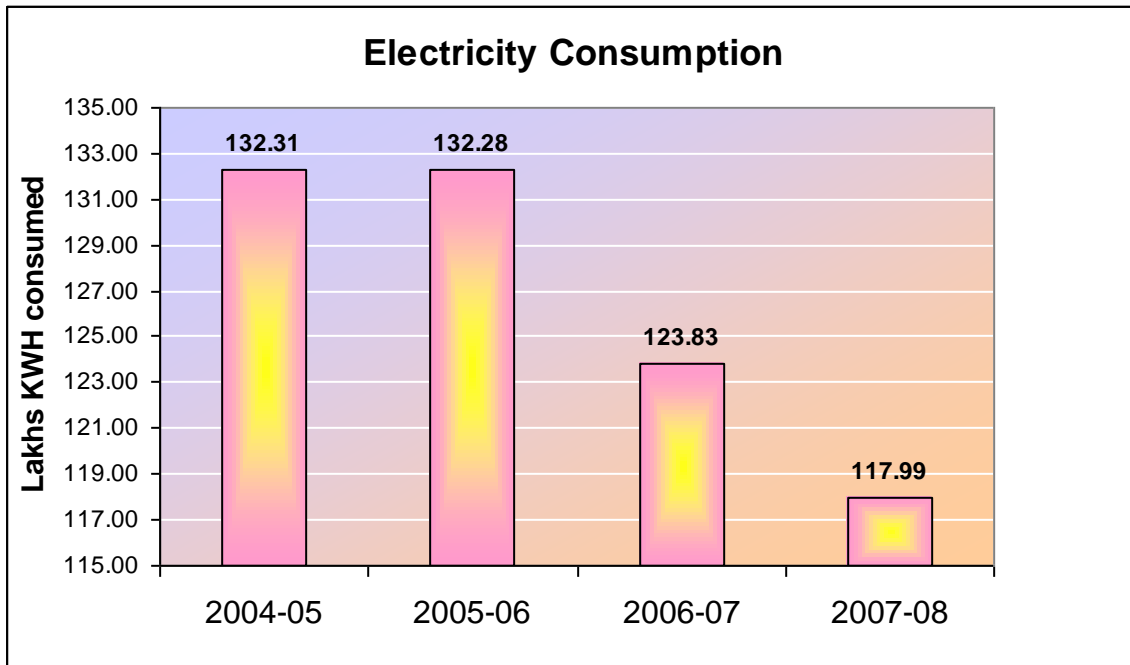

Energy Consumption (Kcal/Sqmt/day)

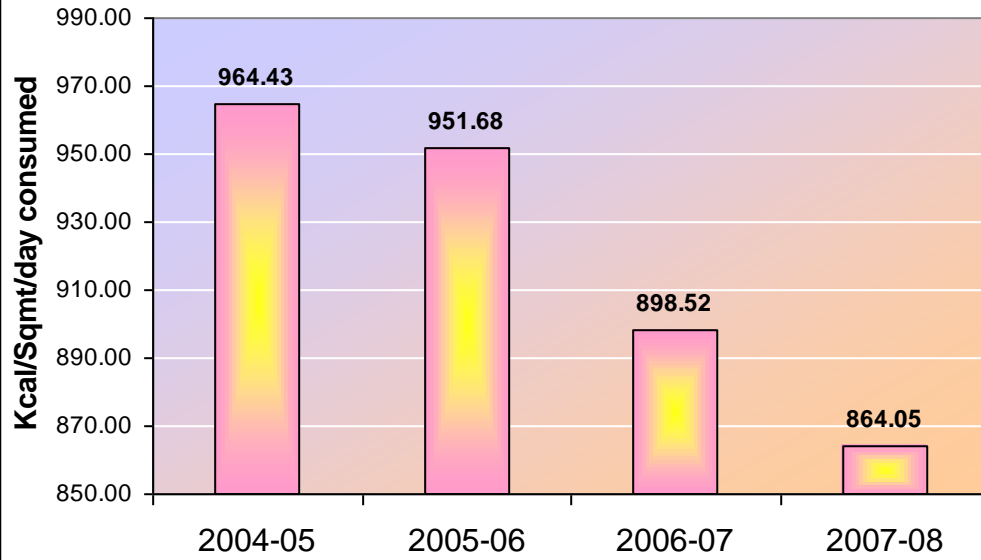

Electricity Cost (in Lakhs)

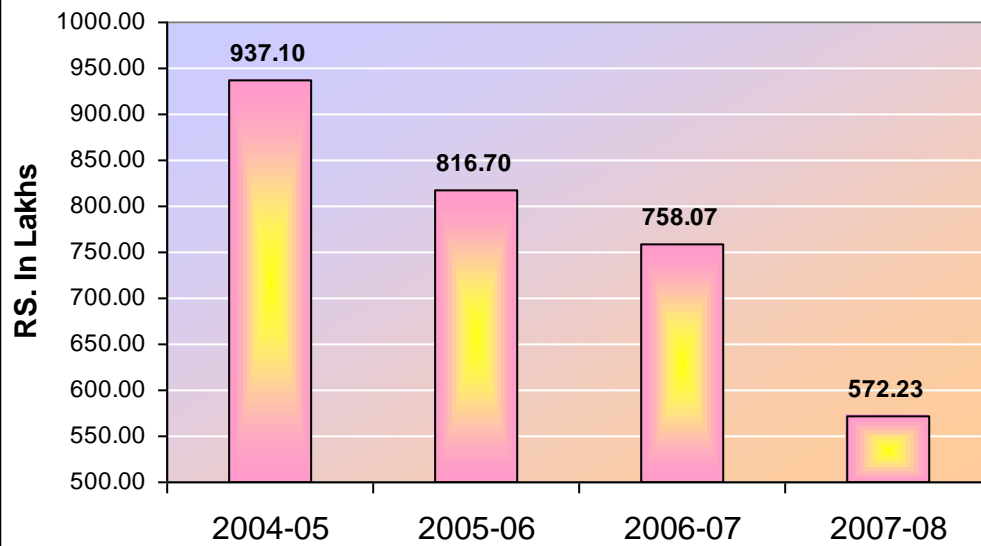

Major Energy Conservation measures implemented at ITC Maurya during 2007-08

1. Replacement of two more fixed speed centrifugal chillers with Variable Speed Screw Chillers(Commissioned Sept 07 and is yielding good results)



Energy Efficient VFD Screw Chillers (02 Nos)

2. Existing EFF-2 motors has been replaced with energy efficient NEMA premium super E Baldor Motors in all the AHU's and TFA's.
3. Installation of State of the art energy efficient PNG fired Gen Set with exhaust heat recovery through exhaust gas boiler to generate steam to operate existing double effect vacuum absorption chiller. (PNG fired generator has been commissioned in Jan'o8 & Exhaust Gas Boiler is under commissioning stage)



Energy efficient PNG fired Engine



Exhaust Gas Boiler

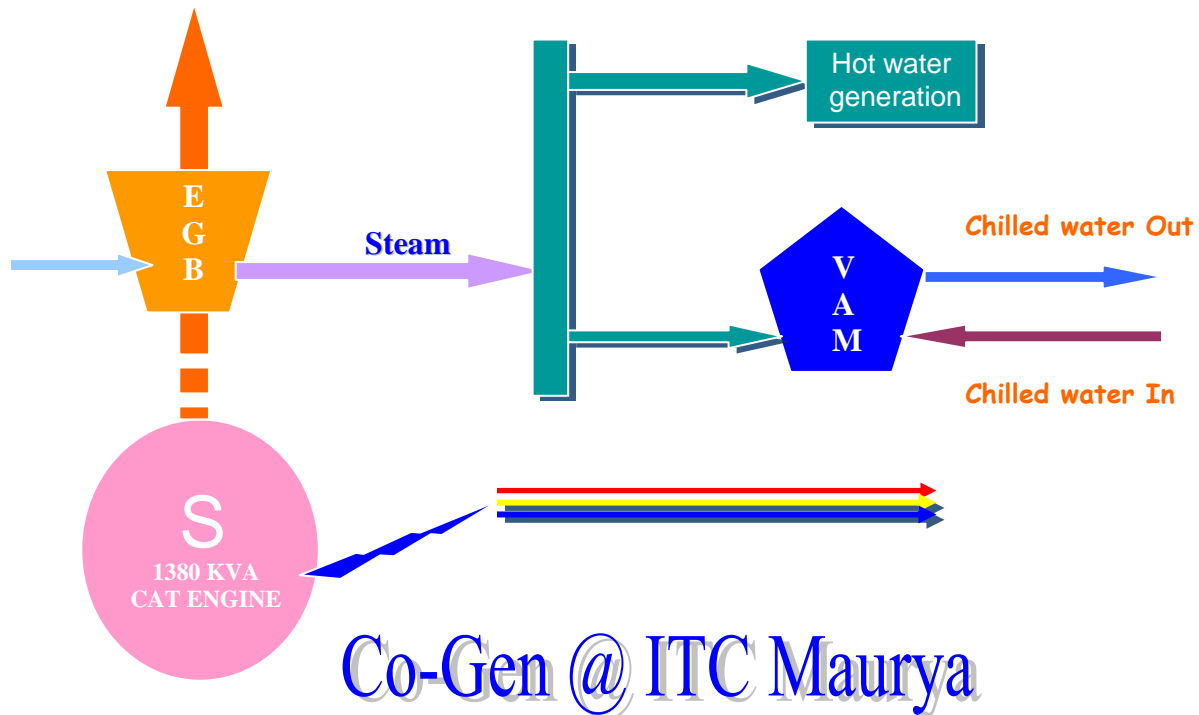

4. **Energy efficient steam boilers in place of old VINTAGE boilers with total steam engineering RE DONE along with state of the art skid mounted plate heat exchangers in place of old shell and tube heat exchangers with proper automation (Commissioned in February-2008 and is yielding good results).**



5. Centralized voltage regulation for lighting circuits in order to save energy.
6. Occupancy Sensors for all guest room bathrooms and public areas.
7. Energy efficient motors for Airconditioning plant.
8. VFD installation(14 Nos) for Exhausts, AHU Motors, Air washers Etc

9. Bifurcation of water line as lower head and higher head requirement to save the pumping energy and for water conservation. (approximate savings of 50 KL water per day)

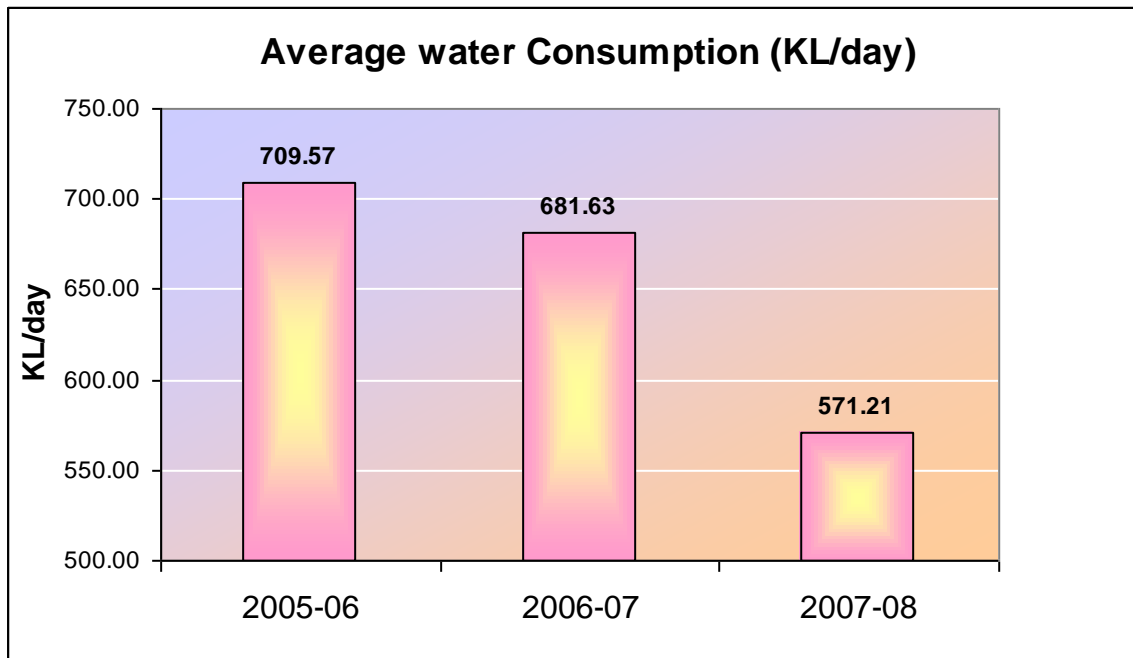

10. As part of Tower block (111 rooms) renovation bed side CFL's have been replaced with energy efficient LED's and also LED's based lights in lift landings corridors etc.
11. Ozone Injection System to Use in the Laundry for Reduction the Chemical and energy.
12. Ozone injection thus reducing fresh air in intake in to AHU's –reduction in air-conditioning load.



13. Old washer extractor have been replaced with energy efficient washers, operated with Variable Frequency Drives.

14. Condensate / Flash steam recovery from Laundry ensures no wastage of energy



Energy conservation measures under implementation during 2008-09

1. All Cold Storages in Main Kitchen Will Be of CFC Free and energy efficient – Stand Alone Cooling Unit.
2. Enhancement of ETP to STP Plant with energy efficient pumps blowers etc
3. Energy efficient PNG fired Calendar machine in place of existing steam heated calendar machine (commissioned in July' 2008 and yielding good results).
4. Direct PNG Fired energy efficient Tumbler Dryer for laundry. (Commissioned in July' 2008).



5. Conversion of the entire Electrical Oven to PNG Oven in kitchen.
6. **Heat Pipes** : for TFA's for RH management and reduction of airconditioning load.
7. Conversion of the entire Electrical Oven to PNG Oven in kitchen.
8. Zonal segregation of chilled water lines to save airconditioning load.
9. Air Separator and expansion tanks in the chilled water loop for effective utilization

10. Dublin airconditioning enhancement.
11. Cooling tower replacement from forced draft to induced draft so as to increase efficiency of air-conditioning system.
12. IBMS for better management of utilities through sensors thus achieving energy savings
13. **HEAT WHEELS:** It is proposed recover wasted thermal energy through Heat wheels from the bath rooms exhaust and re- cool the fresh air entering the building (proposed for two tower buildings)
14. **Project Surya Mukhi:** Solar Concentrator installation to generate steam for steam utilities. It is proposed to install 02 nos of Arun 160 Sqmtr. Solar dishes to generate 400 Kgs of steam per hour during sunny days/time and 12nos of Dishes from Thermax on various loacations on the terraces to generate steam of 75 Kgs/ hour on sunny days/time as shown in the pictures given below:

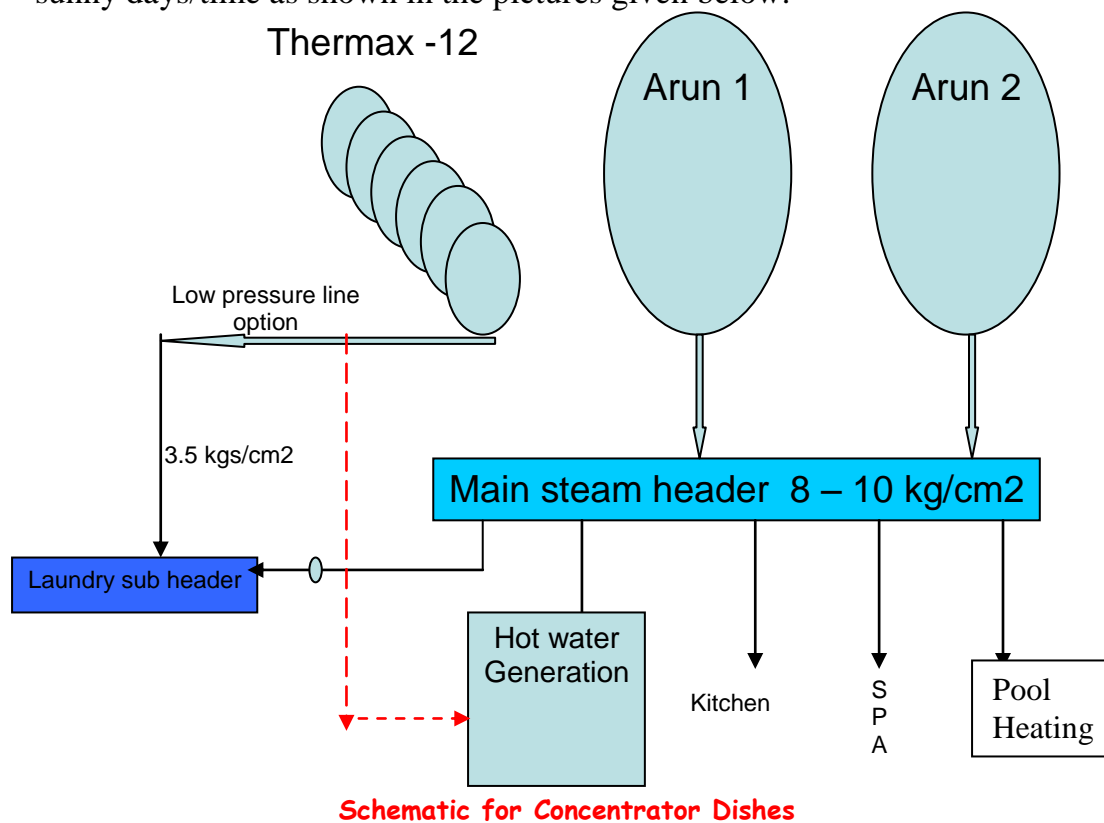

Solar concentrators

1. Thermax dishes-12 nos @ 76 kgs/ Hr each
2. Arun Solar dishes-2 nos @ 200 kgs/ Hr each

Project cost Rs 112 lacs, Commencement- November 08, Completion- January 09, Pay back period-4.8 years

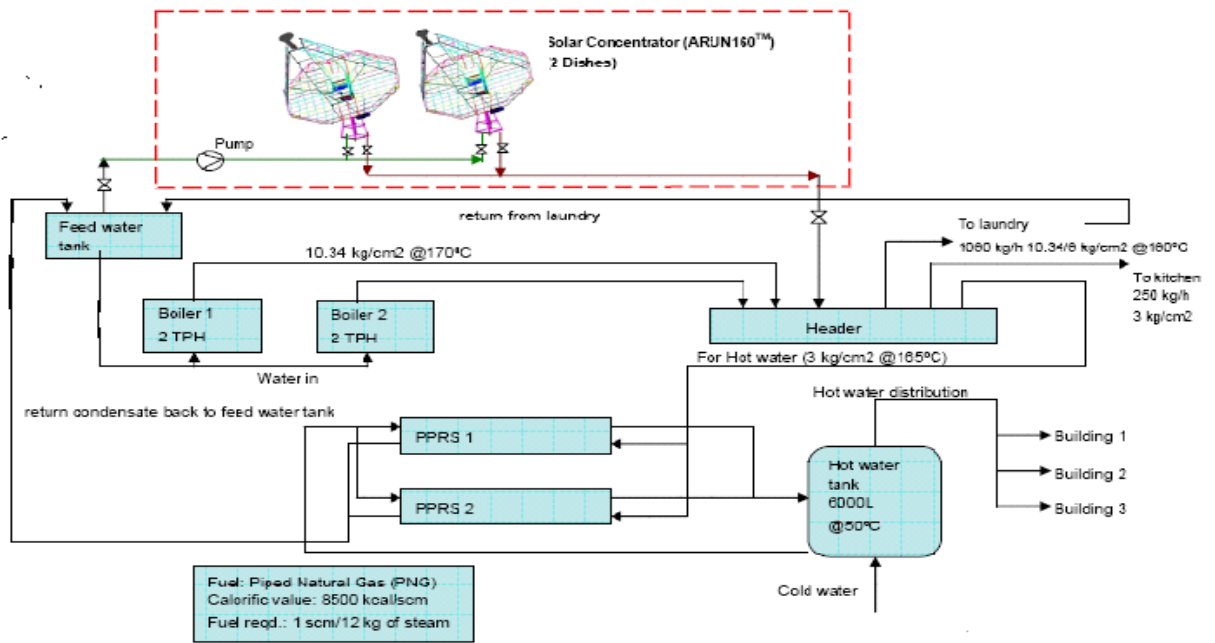

Schematic for ARUN Dishes





Major Energy Conservation measures implemented at ITC Maurya during 2006-07

1. Installation of two nos of VFD operated energy efficient and eco-friendly 19 XR centrifugal compressors chillers. These new chillers were installed replacing two of the existing fixed speed centrifugals which were in good working condition.



2. Installation of primary and secondary chilled water system with highly efficient motors (EFF 1) for airconditioning plant in place of conventional direct pumping..

3. Screw air compressors in place of old reciprocating compressors for laundry air requirement.



4. All transfer pumps and fountain pumps were replaced with energy efficient pumps .
5. Replacement of three way valves to two way valves for all guest room FCUs to work in tandem with the secondary system of pumping. This has resulted in saving energy thru slowing down of the secondary pumps during low load conditions.
6. Rationalization of two transformers as part of electrical system revamp. The reduced number of transformers resulted in energy saving by eliminating the fixed losses
7. Replacement of tri port valves into bi port valves in guest rooms with state of the art thermostats in guest rooms and offices for better energy efficiency.
8. As part of main building room renovation state of the art energy efficient lighting, electronic bed side control panel for the control of lighting and Air conditioning in the guest rooms.
9. Upgradation of automised Capacitor Banks to Maintain Unity Power Factor.
10. Two way Automatic Balancing chilled water valve for Basement /Ground Floor AHU's. operated with thermostats.
11. Usage of Flow Regulating Devices to Extend To All Taps to Reduce Water Consumption thus saving pumping energy
12. New energy efficient cooling towers in place of old cooling towers with VFD operated motors..
13. VFD installation(15 Nos) for DG Exhaust, AHU Motors Etc
14. Installation of kitchen energy star rating equipments during Fist phase of renovation.
15. Saving in PNG achieved by adopting following measure- repairing of pipe line with proper insulation, changed all the steam traps for better utilization of steam and energy.

Energy Conservation at ITC Maurya during 2004-05 & 2005-06

The following energy efficient measures have been implemented in the following areas

1. Building Management System (PC based):- The Building Management System is key centre for retrieving the datas of all AHUs, TFAs & exhaust used for kitchen. It uses DP sensor for sending the details of for eg. For AHU / TFA the load conditions of the corresponding area in terms of return air and supply air temperature, accordingly adjust the frequency for the drive. For the exhaust, being the most essential part for the kitchen operation DP sensor gives the running condition of the exhaust.

2. Energy management strategy for Airconditioning:-

a. Chilled water flow for the all AHUs and TFAs is adjusted by the use of two way **valves** in the pipeline which according to the load adjust the flow of water through the coils.

b. Cooling Towers fans speed is adjusted according to the return water temperature from the Tower and hence, save lots of energy.

c. VFD's for Condenser & Chilled Water Pumps

3. Lighting Upgrade/ Modification: - Extensive use of CFLs and PL bulbs in place of incandescent bulbs. Use of T5 28 watts tube lights in place of ordinary 40 w tubes.

4. Modernization of Elevators:- Hotel has total 14 elevators out of which it has replaced 12 numbers with VVF (variable voltage and frequency) Mitsubishi elevators which according to the load and call adjust its operations.

5. Up gradation of generators: - Installation of 2 numbers 1500 KVA diesel generator which are in accordance with EURO NORMS for environment and energy saving.

6. Installation of Capacitor banks for improving power factor.

7. Installation of Water & Energy Meters for tracking water and electrical consumption.

8. Installation of burners for boilers to use PNG as fuel for energy conservation with almost negligible smoke.

9. Solar Photovoltaic panels for lighting of Hotel sinage generates electricity of 15000 watts per day (a pilot project)

