

HOT ROLLING PROCESS

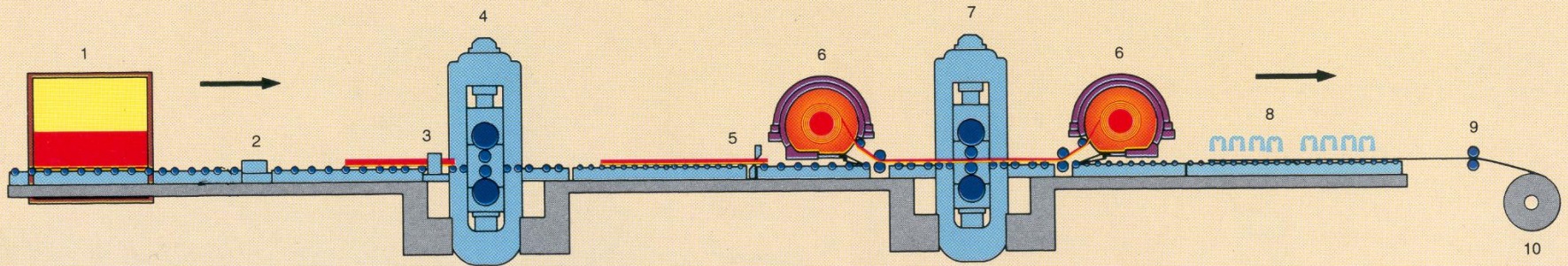

1. Reheating Furnace
2. Descaler
3. Edger

4. Roughing Mill
5. Crop Shear
6. Coiler Furnace

7. Steckel Mill
8. Laminar Cooling
9. Pinch Roll

10. Down Coiler

BLANKING LINE

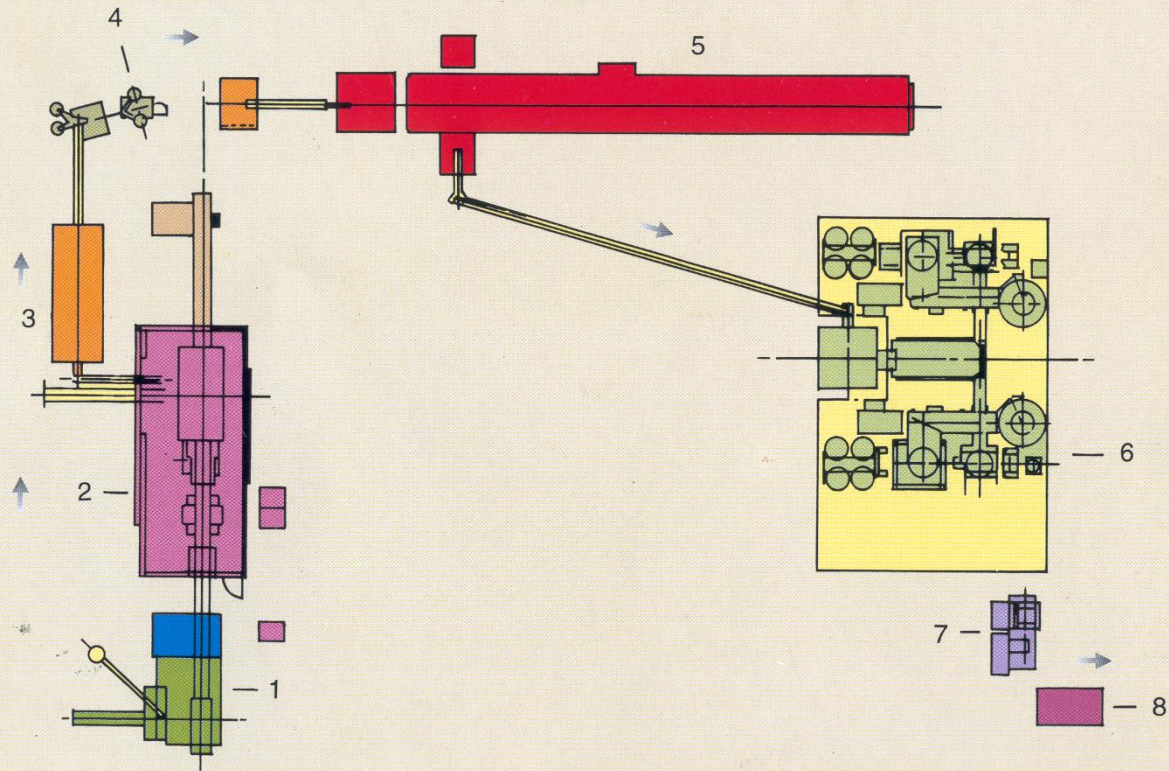

1. Uncoiler
2. Press
3. Drier
4. Rimming Machine

5. Rotary Annealing Furnace
6. Pickling & Polishing Units
7. Counting & Packing
8. Despatch

COLD ROLLING PROCESS

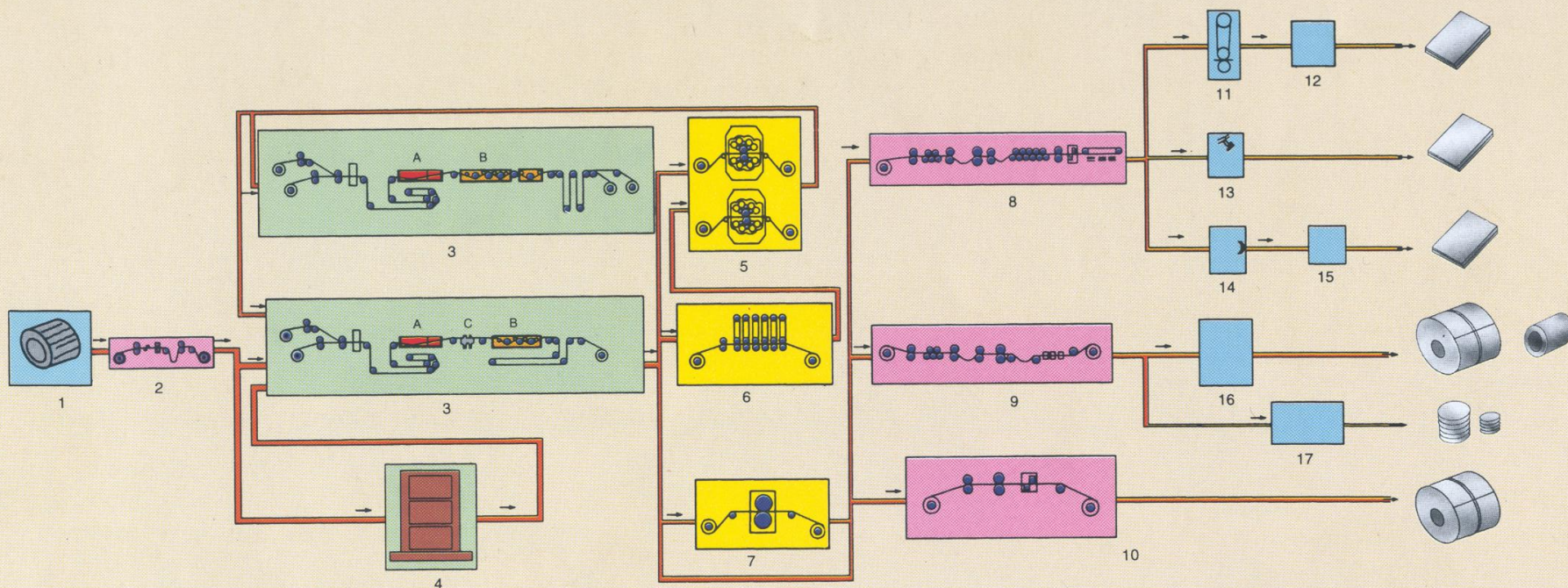

- 1. Hot Rolled Coil
- 2. Coil Buildup Line
- 3. Annealing & Pickling Line
 - A - Annealing
 - B - Pickling
 - C - Shot Blasting
- 4. Bell Annealing Furnace

- 5. Sendzimir Mills
- 6. Strip Grinding Line
- 7. Skinpass Mill
- 8. Shearing Line
- 9. Slitting Line
- 10. Coil Inspection & Dividing Line
- 11. Sheet Grinding & Polishing Line

- 12. PVC Coating Unit
- 13. Sheet Packing Line
- 14. Stretcher Leveller
- 15. Resquaring Shear
- 16. Coil Packing Line
- 17. Blanking Line