

Energy Conservation Measure implemented in 2006-2007

(To be filled up separately for each Energy Conservation Measure)

ID to be filled by BEE	Title of the measure Installation of bagasse silos and boiler automation	Sector Sugar			
Year to be filled by BEE		Technology			
<p>Description of the energy conservation measure:</p> <p>Before installation of bagasse silos, Boiler excess air was fluctuating as indicated by the fluctuation of O₂ in flue gas between 4 – 12 % due to air ingress through the earlier bagasse feeding system.</p> <p>After silos were installed, proper sealing enabled excess air to be optimally controlled (4.5% O₂ in flue gas as indicated by online oxygen analyzer).</p> <p>The project brought improvement in boiler efficiency evident from the increment in steam to fuel ratio, i.e. 2.067 in 2005-06 to 2.185 in 2006-07.</p>					
Picture/ sketch/ drawing before modification (if available)			Picture/ sketch/ drawing after modification		
Not Available					
Agency that executed the project (with complete address and email): In-house					
Total investment, Rs. 147.50 Lakhs			Year of implementation: 2006-07		
First year energy cost savings, Rs. 43.51 Lakhs					
First year other savings, Nil					
On annual basis	kWh 000'	Bagasse (Tons)	Gas Nm ³	Oil (kL)	Other
Energy consumption before	Nil	115291	Nil	Nil	Nil
Energy consumption after	Nil	109065	Nil	Nil	Nil
Energy tariff, Rs/ kWh/ Ton/ Nm ³ / kL ...	Nil	698.8	Nil	Nil	Nil
Company complete address: Nava Bharat Ventures Ltd, Sugar Division, Samalkot East Godavari District, Andhra Pradesh Ph: 0884 - 2327384, Fax: 0884 – 2327587 E - mail: mail@deccansugars.in Contact person who could be contacted for more information: Mr. DVLN Raju, Plant Manager Mail: dvlnr@deccansugars.in				<p>We authorize Bureau to use this information for dissemination</p> <p>Signature</p> <p>Date</p>	

Energy Conservation Measure implemented in 2006-2007

(To be filled up separately for each Energy Conservation Measure)

ID to be filled by BEE	Title of the measure Raise in syrup brix	Sector Sugar			
Year to be filled by BEE		Technology			
Description of the energy conservation measure: Syrup brix at the outlet of quintuple evaporators was increased from 57.23 deg to 65.39 deg maintaining the sugar quality and bold grain percentage. This resulted in reduction in steam consumption at pan floor and hence in the LP steam consumption					
Picture/ sketch/ drawing before modification (if available)			Picture/ sketch/ drawing after modification		
Not applicable			Not applicable		
Agency that executed the project (with complete address and email): In-house					
Total investment, Rs. Nil			Year of implementation: 2006-07		
First year energy cost savings, Rs. 9.44 Lakhs					
First year other savings, Nil					
On annual basis	kWh 000'	Bagasse (Tons)	Gas Nm ³	Oil (kL)	Other
Energy consumption before	Nil	31271.06	Nil	Nil	Nil
Energy consumption after	Nil	29919.57	Nil	Nil	Nil
Energy tariff, Rs/ kWh/ Ton/ Nm ³ / kL ...	Nil	698.8	Nil	Nil	Nil
Company complete address: Nava Bharat Ventures Ltd, Sugar Division, Samalkot East Godavari District, Andhra Pradesh Ph: 0884 - 2327384, Fax: 0884 – 2327587 E - mail: mail@deccansugars.in Contact person who could be contacted for more information: Mr. M. Pandu Ranga Rao, Manager - Process Mail: mpr@deccansugars.in				We authorize Bureau to use this information for dissemination Signature Date	

Energy Conservation Measure implemented in 2006-2007

(To be filled up separately for each Energy Conservation Measure)

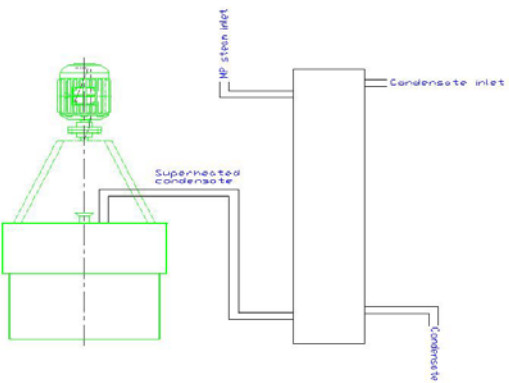
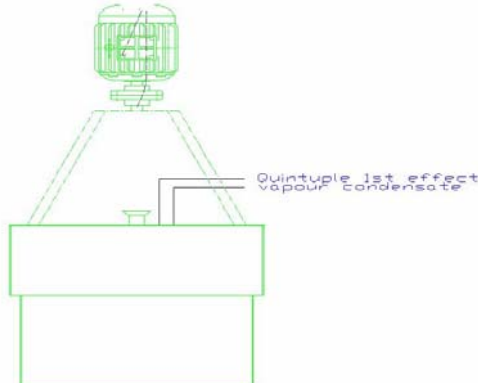
ID to be filled by BEE	Title of the measure Quintuple 1st effect vapour condensate as superheated wash water	Sector Sugar			
Year to be filled by BEE		Technology			
<p>Description of the energy conservation measure:</p> <p>It is general practice to use process condensate which is superheated from 75 deg.C to 115 deg.C using MP steam for washing sugar crystals in batch centrifugals</p> <p>The project utilized quintuple 1st effect vapour condensate directly for washing sugar crystals doing away with the heat exchanger.</p>					
Picture/ sketch/ drawing before modification (if available)	Picture/ sketch/ drawing after modification				
					
Agency that executed the project (with complete address and email): In-house					
Total investment, Rs.: 0.42 Lakhs	Year of implementation: 2006-07				
First year energy cost savings, Rs.: 0.713 Lakhs					
First year other savings, Rs.: Nil					
On annual basis	kWh 000'	Bagasse (Tons)	Gas Nm ³	Oil (kL)	Other
Energy consumption before	Nil	154.63	Nil	Nil	Nil
Energy consumption after	Nil	52.65	Nil	Nil	Nil
Energy tariff, Rs/ Ton	Nil	698.8	Nil	Nil	Nil
Company complete address: Nava Bharat Ventures Ltd, Sugar Division, Samalkot East Godavari District, Andhra Pradesh Ph: 0884 - 2327384, Fax: 0884 – 2327587 E - mail: mail@deccansugars.in Contact person who could be contacted for more information: Mr. M. Pandu Ranga Rao, Manager - Process Mail: mpr@deccansugars.in				<p>We authorise Bureau to use this information for dissemination</p> <p>Signature</p> <p>Date</p>	

Energy Conservation Measure implemented in 2006-2007

(To be filled up separately for each Energy Conservation Measure)

ID to be filled by BEE	Title of the measure Clear Juice in place of condensate	Sector Sugar			
Year to be filled by BEE		Technology			
<p>Description of the energy conservation measure: It is general practice to use process condensate in vacuum pans, continuous centrifugals & sugar melter.</p> <p>Clear juice was used in place of process condensate to possible extent at the above stations. Hence saving in evaporation load is achieved which directly reduced LP steam consumption in process.</p> <p>A total of 1167 T of clear juice is used in place of process condensate, which saved 466.6 T of LP steam.</p>					
Picture/ sketch/ drawing before modification (if available)			Picture/ sketch/ drawing after modification		
Not available					
Agency that executed the project (with complete address and email): In-house					
Total investment, Rs.: 0.65 Lakhs			Year of implementation: 2006-07		
First year energy cost savings, Rs.: 0.84 Lakhs					
First year other savings, Rs.:					
On annual basis	kWh 000'	Bagasse (Tons)	Gas Nm ³	Oil (kL)	Other
Energy consumption before	Nil	120	Nil	Nil	Nil
Energy consumption after	Nil	0	Nil	Nil	Nil
Energy tariff, Rs/ Ton	Nil	698.8	Nil	Nil	Nil
Company complete address: Nava Bharat Ventures Ltd, Sugar Division, Samalkot East Godavari District, Andhra Pradesh Ph: 0884 - 2327384, Fax: 0884 – 2327587 E - mail: mail@deccansugars.in Contact person who could be contacted for more information: Mr. M. Pandu Ranga Rao, Manager - Process Mail: mpr@deccansugars.in				We authorise Bureau to use this information for dissemination Signature Date	

Energy Conservation Measure implemented in 2006-2007

(To be filled up separately for each Energy Conservation Measure)

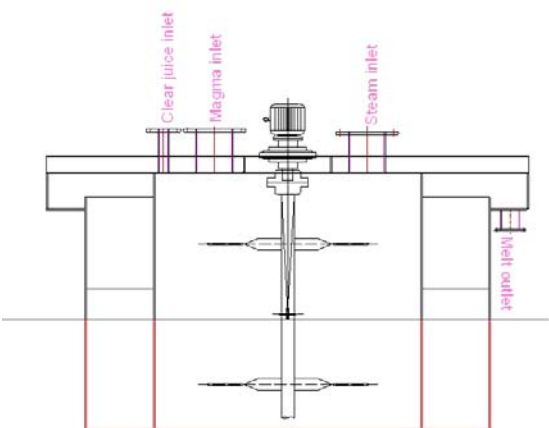
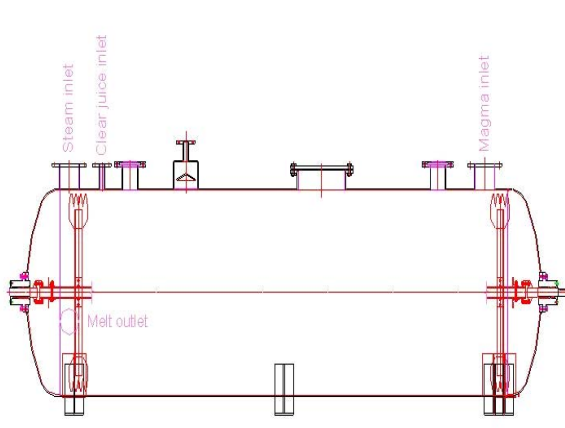
ID to be filled by BEE	Title of the measure Quintuple 3rd effect vapour for sugar melting		Sector Sugar		
Year to be filled by BEE			Technology		
<p>Description of the energy conservation measure: It is general practice to utilize first or LP steam for melting sugar crystals in an open sugar melter.</p> <p>A new horizontal enclosed sugar melter fully insulated was designed in house to utilize quintuple 3rd effect vapour at 98deg.C for sugar melting.</p>					
Picture/ sketch/ drawing before modification (if available)			Picture/ sketch/ drawing after modification		
					
Agency that executed the project (with complete address and email): In-house					
Total investment, Rs.: 10.82 Lakhs			Year of implementation: 2006-07		
First year energy cost savings, Rs.: 9.878 Lakhs					
First year other savings, Nil					
On annual basis	kWh 000'	Bagasse (Tons)	Gas Nm ³	Oil (kL)	Other
Energy consumption before	Nil	2827	Nil	Nil	Nil
Energy consumption after	Nil	1414	Nil	Nil	Nil
Energy tariff, Rs/ kWh/ Ton/ Nm ³ / kL ...	Nil	698.8	Nil	Nil	Nil
Company complete address: Nava Bharat Ventures Ltd, Sugar Division, Samalkot East Godavari District, Andhra Pradesh Ph: 0884 - 2327384, Fax: 0884 – 2327587 E - mail: mail@deccansugars.in Contact person who could be contacted for more information: Mr. M. Pandu Ranga Rao, Manager - Process Mail: mpr@deccansugars.in				We authorise Bureau to use this information for dissemination Signature Date	

Energy Conservation Measure implemented in 2006-2007

(To be filled up separately for each Energy Conservation Measure)

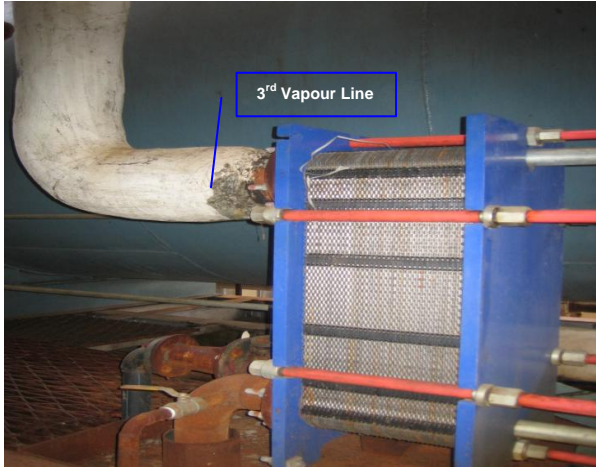
ID to be filled by BEE	Title of the measure Plate heat exchanger for turbine condensate heating	Sector Sugar			
Year to be filled by BEE		Technology			
Description of the energy conservation measure: The exhaust condensate of the condensing turbine combined with DM water makeup for boiler is heated from 40 Deg.C in deaerator using LP steam. After installation of PHE a total of 61931 T of condensate was heated from 40 °C to 98 °C using quintuple 3 rd effect vapour, Saving LP steam of 2879 T.					
Picture/ sketch/ drawing before modification (if available)			Picture/ sketch/ drawing after modification		
Not applicable					
Agency that executed the project (with complete address and email): In-House					
Total investment, Rs.: 2.70 Lakhs			Year of implementation: 2006-07		
First year energy cost savings, Rs.: 6.43 Lakhs					
First year other savings, Nil					
On annual basis	kWh 000'	Bagasse (Tons)	Gas Nm ³	Oil (kL)	Other
Energy consumption before	Nil	1769.30	Nil	Nil	Nil
Energy consumption after	Nil	849.59	Nil	Nil	Nil
Energy tariff, Rs/ Ton	Nil	698.8	Nil	Nil	Nil
Company complete address: Nava Bharat Ventures Ltd, Sugar Division, Samalkot East Godavari District, Andhra Pradesh Ph: 0884 - 2327384, Fax: 0884 – 2327587 E - mail: mail@deccansugars.in Contact person who could be contacted for more information: Mr. DVLN Raju, Plant Manager Mail: dvlnr@deccansugars.in				We authorise Bureau to use this information for dissemination Signature Date	



Energy Conservation Measure implemented in 2006-2007

(To be filled up separately for each Energy Conservation Measure)

ID to be filled by BEE	Title of the measure Energy Saver for factory lighting	Sector Sugar			
Year to be filled by BEE		Technology			
Description of the energy conservation measure: An energy saver was installed to reduce voltage for all lighting loads. Thus saving 0.876 Lakh units.					
Picture/ sketch/ drawing before modification (if available)			Picture/ sketch/ drawing after modification		
Not applicable					
Agency that executed the project (with complete address and email): In-house					
Total investment, Rs.:4.05 Lakhs			Year of implementation: 2006-07		
First year energy cost savings, Rs.: 2.304 Lakhs					
First year other savings, Nil					
On annual basis	kWh 000'	Bagasse (Tons)	Gas Nm ³	Oil (kL)	Other
Energy consumption before	87.6	Nil	Nil	Nil	Nil
Energy consumption after	0	Nil	Nil	Nil	Nil
Energy tariff, Rs/ kWh/ Ton/ Nm ³ / kL ...	2.63	Nil	Nil	Nil	Nil
Company complete address: Nava Bharat Ventures Ltd, Sugar Division, Samalkot East Godavari District, Andhra Pradesh Ph: 0884 - 2327384, Fax: 0884 – 2327587 E - mail: mail@deccansugars.in Contact person who could be contacted for more information: Mr. P Nageswara Rao, Manager - Electrical Mail: pnr@deccansugars.in				We authorize Bureau to use this information for dissemination Signature Date	



Energy Conservation Measure implemented in 2006-2007

(To be filled up separately for each Energy Conservation Measure)

ID to be filled by BEE	Title of the measure Energy Efficient motors		Sector Sugar		
Year to be filled by BEE			Technology		
Description of the energy conservation measure: Replaced 265 HP of old standard efficiency motors with energy efficient motors saving power due to improved motor efficiency.					
Picture/ sketch/ drawing before modification (if available)			Picture/ sketch/ drawing after modification		
					
Agency that executed the project (with complete address and email): In-house					
Total investment, Rs.:3.92 Lakhs			Year of implementation: 2006-07		
First year energy cost savings, Rs.: 0.22 Lakhs					
First year other savings, Nil					
On annual basis	kWh 000'	Bagasse (Tons)	Gas Nm ³	Oil (kL)	Other
Energy consumption before	8000	Nil	Nil	Nil	Nil
Energy consumption after	Nil	Nil	Nil	Nil	Nil
Energy tariff, Rs/ kWh/ Ton/ Nm ³ / kL ...	2.63	Nil	Nil	Nil	Nil
Company complete address: Nava Bharat Ventures Ltd, Sugar Division, Samalkot East Godavari District, Andhra Pradesh Ph: 0884 - 2327384, Fax: 0884 – 2327587 E - mail: mail@deccansugars.in Contact person who could be contacted for more information: Mr. P Nageswara Rao, Manager - Electrical Mail: pnr@deccansugars.in				We authorise Bureau to use this information for dissemination Signature Date	

Energy Conservation Measure implemented in 2006-2007

(To be filled up separately for each Energy Conservation Measure)

ID to be filled by BEE	Title of the measure Replacement of CRT monitors with TFT-LCD monitors	Sector Sugar			
Year to be filled by BEE		Technology			
Description of the energy conservation measure: 60 CRT monitors have been replaced with TFT-LCD monitors saving almost 60% of power consumption.					
Picture/ sketch/ drawing before modification (if available)			Picture/ sketch/ drawing after modification		
					
Agency that executed the project (with complete address and email): In-house					
Total investment, Rs. 5.00 Lakhs			Year of implementation: 2006-07		
First year energy cost savings, Rs.0.18 Lakhs					
First year other savings, Nil					
On annual basis	kWh 000'	Bagasse (Tons)	Gas Nm ³	Oil (kL)	Other
Energy consumption before	6900	Nil	Nil	Nil	Nil
Energy consumption after	Nil	Nil	Nil	Nil	Nil
Energy tariff, Rs/ kWh/ Ton/ Nm ³ / kL ...	2.63	Nil	Nil	Nil	Nil
Company complete address: Nava Bharat Ventures Ltd, Sugar Division, Samalkot East Godavari District, Andhra Pradesh Ph: 0884 - 2327384, Fax: 0884 – 2327587 E - mail: mail@deccansugars.in Contact person who could be contacted for more information: Mr. R. Ravi, Chief Manager - IT Mail: rr@deccansugars.in				We authorise Bureau to use this information for dissemination Signature Date	

Energy Conservation Measure implemented in 2006-2007

(To be filled up separately for each Energy Conservation Measure)

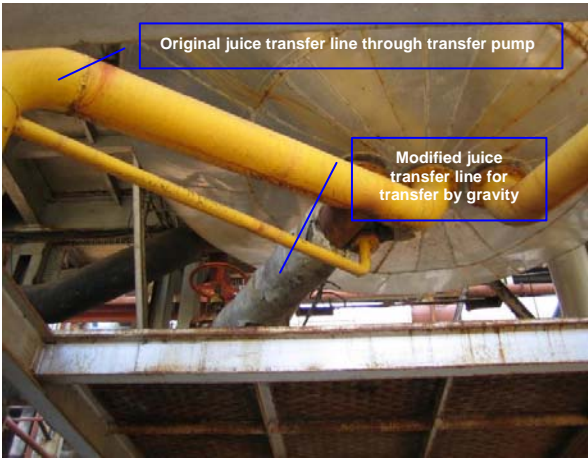
ID to be filled by BEE	Title of the measure Avoiding FFE transfer pump	Sector Sugar			
Year to be filled by BEE		Technology			
Description of the energy conservation measure: Juice transfer scheme was modified and resulting head difference was utilized to completely avoid 15 kW juice transfer pump at falling film evaporator.					
Picture/ sketch/ drawing before modification (if available)			Picture/ sketch/ drawing after modification		
Same photo is applicable →					
Agency that executed the project (with complete address and email): In-house					
Total investment, Rs.: Nil			Year of implementation: 2006-07		
First year energy cost savings, Rs.: 1.113 lakhs					
First year other savings, Nil					
On annual basis	kWh 000'	Bagasse (Tons)	Gas Nm ³	Oil (kL)	Other
Energy consumption before	42.3	Nil	Nil	Nil	Nil
Energy consumption after	0	Nil	Nil	Nil	Nil
Energy tariff, Rs/ kWh	2.63	Nil	Nil	Nil	Nil
Company complete address: Nava Bharat Ventures Ltd, Sugar Division, Samalkot East Godavari District, Andhra Pradesh Ph: 0884 - 2327384, Fax: 0884 – 2327587 E - mail: mail@deccansugars.in Contact person who could be contacted for more information: Mr. M. Pandu Ranga Rao, Manager - Process Mail: mpr@deccansugars.in				We authorise Bureau to use this information for dissemination Signature Date	

Energy Conservation Measure implemented in 2006-2007

(To be filled up separately for each Energy Conservation Measure)

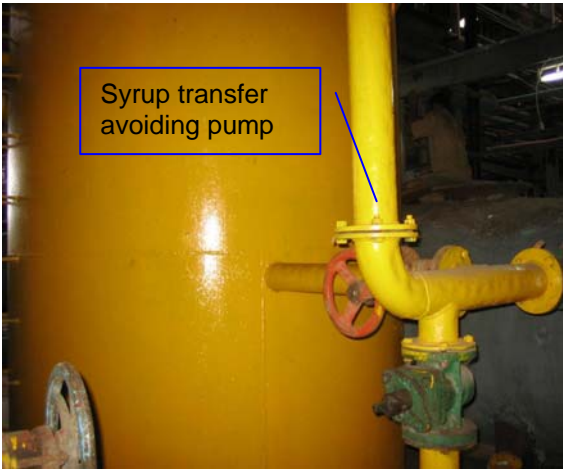
ID to be filled by BEE	Title of the measure Avoiding clarified syrup pump		Sector Sugar		
Year to be filled by BEE			Technology		
Description of the energy conservation measure: Clarified syrup pump was avoided by transferring the syrup by using principle of aspiration due to vacuum					
Picture/ sketch/ drawing before modification (if available)			Picture/ sketch/ drawing after modification		
					
Agency that executed the project (with complete address and email): In-house					
Total investment, Rs. Nil Lakhs			Year of implementation: 2006-07		
First year energy cost savings, Rs. 0.994 Lakhs					
First year other savings, Nil					
On annual basis	kWh 000'	Bagasse (Tons)	Gas Nm ³	Oil (kL)	Other
Energy consumption before	37.80	Nil	Nil	Nil	Nil
Energy consumption after	0.00	Nil	Nil	Nil	Nil
Energy tariff, Rs/ kWh/ Ton/ Nm ³ / kL ...	2.63	Nil	Nil	Nil	Nil
Company complete address: Nava Bharat Ventures Ltd, Sugar Division, Samalkot East Godavari District, Andhra Pradesh Ph: 0884 - 2327384, Fax: 0884 – 2327587 E - mail: mail@deccansugars.in Contact person who could be contacted for more information: Mr. M. Pandu Ranga Rao, Manager - Process Mail: mpr@deccansugars.in				We authorize Bureau to use this information for dissemination Signature Date	

Energy Conservation Measure implemented in 2006-2007

(To be filled up separately for each Energy Conservation Measure)

ID to be filled by BEE	Title of the measure Avoiding raw filtrate juice pump		Sector Sugar		
Year to be filled by BEE			Technology		
Description of the energy conservation measure: Raw filtrate pumping was avoided by utilizing the available gravity flow					
Picture/ sketch/ drawing before modification (if available)			Picture/ sketch/ drawing after modification		
Not available			Not available		
Agency that executed the project (with complete address and email): In-house					
Total investment, Rs. Nil			Year of implementation: 2006-07		
First year energy cost savings, Rs. 0.426 Lakhs					
First year other savings, Nil					
On annual basis	kWh 000'	Bagasse (Tons)	Gas Nm ³	Oil (kL)	Other
Energy consumption before	16.20	Nil	Nil	Nil	Nil
Energy consumption after	0.00	Nil	Nil	Nil	Nil
Energy tariff, Rs/ kWh/ Ton/ Nm ³ / kL ...	2.63	Nil	Nil	Nil	Nil
Company complete address: Nava Bharat Ventures Ltd, Sugar Division, Samalkot East Godavari District, Andhra Pradesh Ph: 0884 - 2327384, Fax: 0884 – 2327587 E - mail: mail@deccansugars.in Contact person who could be contacted for more information: Mr. M. Pandu Ranga Rao, Manager - Process Mail: mpr@deccansugars.in				We authorize Bureau to use this information for dissemination Signature Date	

Energy Conservation Measure implemented in 2006-2007

(To be filled up separately for each Energy Conservation Measure)

ID to be filled by BEE	Title of the measure Quintuple 1st effect vapour for FBD sugar dryer air heating	Sector Sugar			
Year to be filled by BEE		Technology			
<p>Description of the energy conservation measure:</p> <p>It is general practice to use MP steam for heating air in fluidized bed sugar dryer. The heat in MP steam condensate is thus lost through drain as waste</p> <p>The project utilized the same heat exchanger with quintuple 1st vapour as heating medium to heat FD air.</p>					
Picture/ sketch/ drawing before modification (if available)			Picture/ sketch/ drawing after modification		
Same photo is applicable →					
Agency that executed the project (with complete address and email): In-House					
Total investment, Rs.: Nil			Year of implementation: 2006-07		
First year energy cost savings, Rs.: 1.046 Lakhs					
First year other savings, Nil					
On annual basis	kWh 000'	Bagasse (Tons)	Gas Nm ³	Oil (kL)	Other
Energy consumption before	Nil	378.32	Nil	Nil	Nil
Energy consumption after	Nil	228.58	Nil	Nil	Nil
Energy tariff, Rs/ kWh/ Ton/ Nm ³ / kL ...	Nil	698.8	Nil	Nil	Nil
Company complete address: Nava Bharat Ventures Ltd, Sugar Division, Samalkot East Godavari District, Andhra Pradesh Ph: 0884 - 2327384, Fax: 0884 – 2327587 E - mail: mail@deccansugars.in Contact person who could be contacted for more information: Mr. M. Pandu Ranga Rao, Manager - Process Mail: mpr@deccansugars.in				We authorise Bureau to use this information for dissemination Signature Date	

Energy Conservation Measure implemented in 2006-2007

(To be filled up separately for each Energy Conservation Measure)

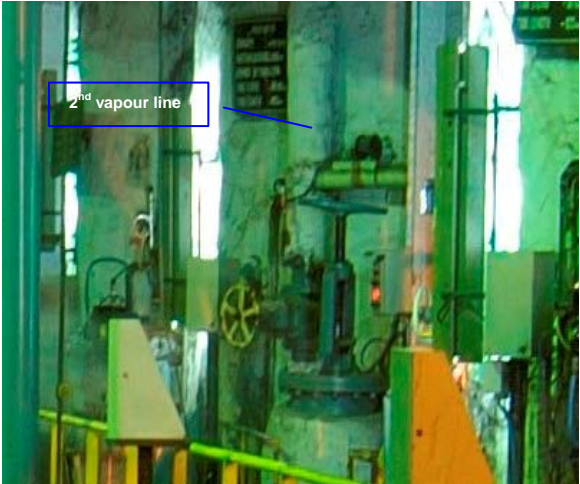
ID to be filled by BEE	Title of the measure Pan washing with 2nd vapour	Sector Sugar			
Year to be filled by BEE		Technology			
<p>Description of the energy conservation measure: In general, pans are washed off sugar crystals / massecuite at the end of cycle using LP steam directly.</p> <p>Realizing the potential, quintuple 2nd effect vapour at conditions adequate for pan washing was utilized saving 117 T of LP steam</p>					
Picture/ sketch/ drawing before modification (if available)			Picture/ sketch/ drawing after modification		
Same photo is applicable →					
Agency that executed the project (with complete address and email): In-house					
Total investment, Rs.: Nil			Year of implementation: 2006-07		
First year energy cost savings, Rs.: 0.21 lakhs					
First year other savings, Nil					
On annual basis	kWh 000'	Bagasse (Tons)	Gas Nm ³	Oil (kL)	Other
Energy consumption before	Nil	120.30	Nil	Nil	Nil
Energy consumption after	Nil	90.22	Nil	Nil	Nil
Energy tariff, Rs/ kWh/ Ton/ Nm ³ / kL ...	Nil	698.8	Nil	Nil	Nil
Company complete address: Nava Bharat Ventures Ltd, Sugar Division, Samalkot East Godavari District, Andhra Pradesh Ph: 0884 - 2327384, Fax: 0884 – 2327587 E - mail: mail@deccansugars.in Contact person who could be contacted for more information: Mr. M. Pandu Ranga Rao, Manager - Process Mail: mpr@deccansugars.in				We authorise Bureau to use this information for dissemination Signature Date	

Energy Conservation Measure implemented in 2006-2007

(To be filled up separately for each Energy Conservation Measure)

ID to be filled by BEE	Title of the measure Sequential circulation of non-condensable gases	Sector Sugar
Year to be filled by BEE		Technology
<p>Description of the energy conservation measure:</p> <p>It is a general practice to vent the non condensable gases (NCG) evolved in evaporators. But a considerable amount of useful steam is also vented along with NCG.</p> <p>In this project the non condensable gases evolved in evaporators are sequentially circulated in quintuple evaporator set to recover the escaping heat present in the gases.</p>		
Picture/ sketch/ drawing before modification (if available)	Picture/ sketch/ drawing after modification	
		
Agency that executed the project (with complete address and email): In-house		
Total investment, Rs. Nil	Year of implementation: 2006-07	
First year energy cost savings, Rs. 1.84 Lakhs		
First year other savings, Nil		
On annual basis	kWh 000'	Bagasse (Tons)
Energy consumption before	Nil	263
Energy consumption after	Nil	0.00
Energy tariff, Rs/ kWh/ Ton/ Nm ³ / kL ...	Nil	698.8
<p>Company complete address:</p> <p>Nava Bharat Ventures Ltd, Sugar Division, Samalkot East Godavari District, Andhra Pradesh</p> <p>Ph: 0884 - 2327384, Fax: 0884 – 2327587 E - mail: mail@deccansugars.in</p> <p>Contact person who could be contacted for more information:</p> <p>Mr. M. Pandu Ranga Rao, Manager - Process Mail: mpr@deccansugars.in</p>		<p>We authorize Bureau to use this information for dissemination</p> <p>Signature</p> <p>Date</p>

Energy Conservation Measure implemented in 2006-2007

(To be filled up separately for each Energy Conservation Measure)

ID to be filled by BEE	Title of the measure Utilization of soda boiling vapours	Sector Sugar			
Year to be filled by BEE		Technology			
<p>Description of the energy conservation measure:</p> <p>In general the soda boiling vapours are vent to atmosphere.</p> <p>The vapours are now mixed with the main stream to recover the heat to process from these vapours.</p>					
Picture/ sketch/ drawing before modification (if available)			Picture/ sketch/ drawing after modification		
					
Agency that executed the project (with complete address and email): In-house					
Total investment, Rs. Nil			Year of implementation: 2006-07		
First year energy cost savings, Rs. 2.63 Lakhs					
First year other savings, Nil					
On annual basis	kWh 000'	Bagasse (Tons)	Gas Nm ³	Oil (kL)	Other
Energy consumption before	Nil	376	Nil	Nil	Nil
Energy consumption after	Nil	0.00	Nil	Nil	Nil
Energy tariff, Rs/ kWh/ Ton/ Nm ³ / kL ...	Nil	698.8	Nil	Nil	Nil
<p>Company complete address:</p> <p>Nava Bharat Ventures Ltd, Sugar Division, Samalkot East Godavari District, Andhra Pradesh</p> <p>Ph: 0884 - 2327384, Fax: 0884 – 2327587 E - mail: mail@deccansugars.in</p> <p>Contact person who could be contacted for more information:</p> <p>Mr. M. Pandu Ranga Rao, Manager - Process Mail: mpr@deccansugars.in</p>				<p>We authorize Bureau to use this information for dissemination</p> <p>Signature</p> <p>Date</p>	