

## Energy Conservation Measure implemented in 2006-2007



(To be filled up separately for each Energy Conservation Measure)

ID to be filled by BEE	Title of the measure Optimization of combustion parameters in Coke Oven batteries	Sector Iron & steel			
Year to be filled by BEE		Technology Thermal			
<p>Description of the energy conservation measure:</p> <p>In the process of coke making at Coke ovens, coking coal is heated in coke oven in the absence of air. The heating requirements of ovens are met by burning either Coke oven gas or mixture of coke oven gas and Blast Furnace gas. It is observed during heat balance of coke oven batteries that heat loss through flue gases was high and accounts for about 15% of fuel input. Therefore reduction of flue gas loss is necessary for improving thermal efficiency of the batteries. The following activities are taken</p> <ol style="list-style-type: none"> <li>i. Timely pushing and charging of ovens(Maintaining Pushing Regularity Index at 0.98 and Coking Regularity Index at 0.98)</li> <li>ii. Maintaining coefficient of temperature uniformity (Kb) above 0.8, there by avoiding high and low temperatures.</li> <li>iii. Reduction of Excess air coefficient from 1.39 to 1.35 by maintaining draft and arresting all the leakages.</li> <li>iv. Monitoring Regenerator/Bus flue cross leakages.</li> <li>v. Stabilization of cross wall temperatures once in every six months.</li> <li>vi. Physical inspection of all the flues of battery once in a month.</li> <li>vii. Reduction of finger plate opening from 80 mm to 70 mm on Pusher side and from 90 mm to 80 m on coke side.</li> <li>viii. Reducing Chimney draft reduced from 28/30 mm to 26/28 mm on coke side as well as pusher side respectively.</li> <li>ix. Rectification of leaks on horizontal branch pipes of waste heat boxes.</li> </ol>					
<b>Picture/ sketch/ drawing before modification</b> (if available)		<b>Picture/ sketch/ drawing after modification</b>			
		<ol style="list-style-type: none"> <li>i) <b>Excess Air is reduced from 1.39 to 1.35 by maintaining draft</b></li> <li>ii) Maintaining coefficient of temperature uniformity (Kb) above 0.8, there by avoiding high and low temperatures.</li> <li>iii) Rectification of leaks on horizontal branch pipes of waste heat boxes.</li> </ol>			
Agency that executed the project (with complete address and email): In-house efforts					
Total investment, Rs.:			Year of implementation:2006		
First year energy cost savings, Rs.: 374.58 Lakhs					
First year other savings, Rs.:					
On annual basis	kWh 000'	Coal (Tons)	Gas Lakh Nm <sup>3</sup>	Oil (kL)	Other Mcal/t
Energy consumption before			9514		
Energy consumption after			9075		
Energy tariff, Rs/ kWh/ Ton/ Nm <sup>3</sup> / kL ...			0.85		
Company complete address: Rashtiya Ispat Nigam Limited Visakhapatnam Steel Plant Visakhapatnam 530032 Contact person who could be contacted for more information: B K Prabhu <b>General Manager(Utilities)</b>				We authorise Bureau to use this information for dissemination  Signature  Date	

**Note: Please submit this sheet separately for each Energy Conservation Measure implemented in 2006-2007.**

## Energy Conservation Measure implemented in 2006-2007

(To be filled up separately for each Energy Conservation Measure)

ID to be filled by BEE	Title of the measure <b>Reduction of fuel consumption in Sinter Ignition furnace</b>	Sector Iron & steel			
Year to be filled by BEE		Technology ...Thermal			
<p>Description of the energy conservation measure:</p> <p>Sintering is a process in which heat is produced by combustion of coke breeze which is moving bed of fine sized materials such as iron ore dust, sludge etc so as to agglomerate the loose particles into a compact porous mass(called sinter) for use in blast furnace as raw material for iron making. Sinter Ignition furnace uses mixed gas for burning of agglomerate.</p> <p>In earlier modification, the working zone length of ignition furnace was reduced to 50% and accordingly 10 out of 20 burners were blanked. All the six window boxes below the furnace were throttled in order to control the pressure in the working zone. However ,the pressure control was poor due to the negative influence of the idle zone on the working zone as there was no partition wall between these two zones. An idle zone provided with additional air supply lines. These are from the existing air supply fan to the furnace. As a result of filling of the vacuum /empty space in the idle zone of furnace, the pressure control of the firing/working zone has improved and temperature control also become very smooth. In addition to this, wind boxes 4,5&amp;6 were fully opened for the purpose of sintering. As a result of improved control over furnace atmosphere and reduced false air influence in fuel combustion, the fuel consumption reduced. The specific heat consumption reduced from 34 Mcal/t to 32 Mcal/t during the year.</p>					
<b>Picture/ sketch/ drawing before modification</b> (if available)			<b>Picture/ sketch/ drawing after modification</b>		
					
Agency that executed the project (with complete address and email): In House efforts					
Total investment, Rs.:			Year of implementation: 2006		
First year energy cost savings, Rs.: 48.67 Lakhs					
First year other savings, Rs.:					
On annual basis	kWh 000'	Coal (Tons)	Gas Lakh Nm <sup>3</sup>	Oil (kL)	Other Mcal/t
Energy consumption before			969		
Energy consumption after			912		
Energy tariff, Rs/ kWh/ Ton/ Nm <sup>3</sup> / kL ...			0.85		
Company complete address: Rashtiya Ispat Nigam Limited Visakhapatnam Steel Plant Visakhapatnam 530032 Contact person who could be contacted for more information: <b>B K Prabhu</b> <b>General Manager(Utilities)</b>				We authorize Bureau to use this information for dissemination  Signature  Date	

## Energy Conservation Measure implemented in 2006-2007

(To be filled up separately for each Energy Conservation Measure)

ID to be filled by BEE	Title of the measure Conservation of electrical energy in Coke oven batteries		Sector Iron & Steel			
Year to be filled by BEE			Technology Electrical			
<p>Description of the energy conservation measure: Coke Ovens is one of the major consumer of electrical energy and having 42 motors of 6.6 KV capacity and 2570 motors of 415 V. Electricity is used in mill fans and hammer crushers and pumps of water supply. The following activities are initiated to reduce electrical energy.</p> <ul style="list-style-type: none"> <li>Installed Variable frequency drives for Conveyor Y11(180 KW),CSP Dust Extraction fans,CDCP Ventilation fans,Pusher Car-3 Pusher ram,DE-5 Door extractor Ram,Skip Hoist of Battery 1&amp;2 ,CDCP Discharging device,Dozimeter. About 38 Variable frequency drives were installed and resulted in energy savings of 288 KW .</li> <li>To reduce number of starts of HT motors by clubbing the shutdown requirement of electrical / mechanical /external agencies.</li> <li>To reduce running hours of HT motors during testing of vibration checking / online balancing /exhauster changeover.</li> <li>Energy Saver for Lighting system</li> </ul>						
Picture/ sketch/ drawing before modification(if available).			Picture/ sketch/ drawing after modification			
Agency that executed the project (with complete address and email): Inhouse efforts						
Total investment, Rs.:			Year of implementation:2006			
First year energy cost savings, Rs.:65.03 lakhs						
First year other savings, Rs.:						
On annual basis	kWh 000'	Coal (Tons)	Gas Nm <sup>3</sup>	Oil (kL)	Other	
Energy consumption before	148405					
Energy consumption after	145804					
Energy tariff, Rs/ kWh/ Ton/ Nm <sup>3</sup> / kL ...	2.5					
Company complete address: Rashtiya Ispat Nigam Limited Visakhapatnam Steel Plant Visakhapatnam 530032 Contact person who could be contacted for more information: <b>B K Prabhu</b> <b>General Manager(Utilities)</b>				We authorise Bureau to use this information for dissemination  Signature  Date		

## Energy Conservation Measure implemented in 2006-2007

(To be filled up separately for each Energy Conservation Measure)

ID to be filled by BEE	Title of the measure Electrical Energy optimization at Sinter blower fans, exhausters	Sector Iron & Steel			
Year to be filled by BEE		Technology Electrical			
<p>Description of the energy conservation measure: Electricity is consumed in the operation of exhausters fan motors, de dusting fan, and sinter cooler blower fans. The Exhaust fan motors account for about 65% of total energy consumed in the sinter making. Sinter Plant has 4 Nos of exhauster fans of 5.6 MW of capacity each. The power consumption in exhausters is dependent upon the tightness of the suction system, sinter bed permeability, power factor control and frequency. Continuity in sinter machine operation i.e. minimum stoppages helps in stabilizing power consumption. The following measures were taken for reducing energy consumption in SP.</p> <ul style="list-style-type: none"> <li>• Minimizing idle running of equipment during normal operation.</li> <li>• Arresting leakages in vacuum chambers.</li> <li>• Installed variable frequency drives for Weigh feeders, Vibrofeeders in Raw Material Bins, Twin boom stacker in Base Mix yard, Conveyors in Sinter Machine Building . About 34 Variable frequency drives were installed in Sinter Plant.</li> <li>• Stopping the major HT drives during stoppage of machine for more than four hours</li> <li>• Installed Energy Savers for Lighting system</li> </ul>					
Picture/ sketch/ drawing before modification(if available).			Picture/ sketch/ drawing after modification		
Agency that executed the project (with complete address and email): In house efforts					
Total investment, Rs.:			Year of implementation: 2006		
First year energy cost savings, Rs.:173.83 Lakhs					
First year other savings, Rs.:					
On annual basis	kWh 000'	Coal (Tons)	Gas Nm <sup>3</sup>	Oil (kL)	Other
Energy consumption before	272945				
Energy consumption after	265991				
Energy tariff, Rs/ kWh/ Ton/ Nm <sup>3</sup> / kL ...	2.5				
Company complete address: Rashtiya Ispat Nigam Limited Visakhapatnam Steel Plant Visakhapatnam 530032 Contact person who could be contacted for more information: <b>B K Prabhu</b> General Manager(Uilities)				We authorize Bureau to use this information for dissemination  Signature  Date	

## Energy Conservation Measure implemented in 2006-2007

(To be filled up separately for each Energy Conservation Measure)

ID to be filled by BEE	Title of the measure Improving Tundish life by optimization of heating time at SMS tundishes	Sector ...Iron & steel...			
Year to be filled by BEE		Technology ...Thermal			
Description of the energy conservation measure:					
<p>The hot metal ladles and tundish heaters are heated by using coke oven gas. The amount of coke oven gas consumption is varying and not continuous due to nature of usage of ladles. The heating cycle time for ladles is about 8 hrs and 2hrs for tundishes. Some times, even the tundish is heated to required temperature, tundish is not used resulting in excessive heating. The metering system needs optimization. The following measures were taken for for reducing thermal energy consumption.</p>					
<ul style="list-style-type: none"> <li>i. Maintaining correct air fuel ratio.</li> <li>ii. Adjusting the flame</li> <li>iii. Replacement of gate valves with plug valves and reduction of co gas pipe line dia.from 100 mm to 65 mm.</li> </ul>					
Picture/ sketch/ drawing before modification(if available).			Picture/ sketch/ drawing after modification		
Agency that executed the project (with complete address and email): In house efforts					
Total investment, Rs.:			Year of implementation:2006		
First year energy cost savings, Rs.:16.23 lakhs					
First year other savings, Rs.:					
On annual basis	kWh 000'	Coal (Tons)	Gas Lakh Nm <sup>3</sup>	Oil (kL)	Other Mcal/t
Energy consumption before			631		
Energy consumption after			613		
Energy tariff, Rs/ kWh/ Ton/ Nm <sup>3</sup> / kL ...			0.85		
Company complete address: Rashtiya Ispat Nigam Limited Visakhapatnam Steel Plant Visakhapatnam 530032 Contact person who could be contacted for more information: <b>B K Prabhu</b> General Manager(Utilities)				We authorise Bureau to use this information for dissemination  Signature  Date	

## Energy Conservation Measure implemented in 2006-2007

(To be filled up separately for each Energy Conservation Measure)

ID to be filled by BEE	Title of the measure Electrical Energy Conservation at Steel Melt shop		Sector Iron & Steel			
Year to be filled by BEE			Technology Electrical			
<p><b>Description of the energy conservation measure:</b>                  Steel melt shop consumed about 3% of total energy requirement. The majority of electricity is consumed in the operation of gas cleaning plant induced draft fans, combustion air blowers ladle furnaces, IRUT furnaces, over head cranes, Steam exhaust controller etc. .                  Electrical energy consumption is reduced by under taking the following</p> <ul style="list-style-type: none"> <li>• Installation of various frequency drives for Bloom Storage Yard Main Hoist(135 KW),BSY LT Crane, Roller Table gear box, Aluminum Wire feeder ,GCM LT gear box. About 55 Variable frequency drives were installed in Steel Melting shop reduced electricity consumption by about 250 KW.</li> <li>• Auto operated IRUT ID fan by installing interlock to operate during blowing .</li> </ul>						
Picture/ sketch/ drawing before modification(if available).			Picture/ sketch/ drawing after modification			
Agency that executed the project (with complete address and email): In house efforts						
Total investment, Rs.:			Year of implementation: 2006			
First year energy cost savings, Rs.: 63.1 Lakhs						
First year other savings, Rs.:						
On annual basis	kWh 000'	Coal (Tons)	Gas Nm <sup>3</sup>	Oil (kL)	Other	
Energy consumption before	141002					
Energy consumption after	138477					
Energy tariff, Rs/ kWh/ Ton/ Nm <sup>3</sup> / kL ...	2.5					
Company complete address: Rashtiya Ispat Nigam Limited Visakhapatnam Steel Plant Visakhapatnam 530032 Contact person who could be contacted for more information: <b>B K Prabhu</b> General Manager(Utilities)				We authorise Bureau to use this information for dissemination  Signature  Date		

## Energy Conservation Measure implemented in 2006-2007

(To be filled up separately for each Energy Conservation Measure)

ID to be filled by BEE	Title of the measure Rationalization of heat distribution and controlling air ingress at Billet Mill reheating furnaces	Sector ...Iron & steel...			
Year to be filled by BEE		Technology ...Thermal			
<p>Description of the energy conservation measure:</p> <p>The blooms are reheated in LMMM reheating furnaces for further rolling to billets. These furnaces are heated by mixed gas and flue gases exit through chimney. The walking beam furnace contains six zones with heat capacity of 60 Gcal/hr. It is observed that the fuel consumption in billet mill reheating furnaces is high due to uneven heat distribution in the furnace and also due to operating heating zones in manual mode. Heat is also lost due to air filtration from water troughs resulting in higher scale formation and increase in fuel consumption.</p> <p>To balance the heat distribution in the reheating furnace, the third row of zone 1 is merged with zone-2. Merging of one row of preheating zone with heating zone-2 balanced heat distribution in the furnace. Operating heating zones in Cascade mode reduce heat loss thro' flue gas. Repair of water troughs in the furnace reduce heat loss from the furnace. Implementation above measures reduced fuel input to the furnace.</p>					
<b>Picture/ sketch/ drawing before modification</b> (if available)			<b>Picture/ sketch/ drawing after modification</b>		
					
Agency that executed the project (with complete address and email): In house efforts					
Total investment, Rs.:			Year of implementation: 2006		
First year energy cost savings, Rs.: 234.9 Lakhs					
First year other savings, Rs.:					
On annual basis	kWh 000'	Coal (Tons)	Gas Lakh Nm <sup>3</sup>	Oil (kL)	Other Mcal/t
Energy consumption before			5127		
Energy consumption after			4866		
Energy tariff, Rs/ kWh/ Ton/ Nm <sup>3</sup> / kL ...			0.85		
Company complete address: Rashtiya Ispat Nigam Limited Visakhapatnam Steel Plant Visakhapatnam 530032 Contact person who could be contacted for more information: <b>B K Prabhu</b> General Manager(Utilites)				We authorise Bureau to use this information for dissemination   Signature  Date	

## Energy Conservation Measure implemented in 2006-2007

(To be filled up separately for each Energy Conservation Measure)

ID to be filled by BEE	Title of the measure Optimization of power consumption in Wire rod mill	Sector Iron & Steel			
Year to be filled by BEE		Technology Electrical			
<b>Description of the energy conservation measure:</b>					
<p>Wire rod mill is designed to roll billets of 125 mm square to different sizes of less than 16 mm. Electricity is consumed in the running of combustion air blowers, rolling drives and over head cranes and high bay lights. The wire rod after rolling from billets is cooled by stelmore blowers.</p> <p>It is observed that some of equipment are not stooped during The following measures were taken for for reducing thermal energy consumption.</p> <ul style="list-style-type: none"> <li>a) Reducing the idle running</li> <li>b) Energy saver in bay lighting</li> <li>c) Switching off stelmore blowers (2 to 9) during Re bar rolling</li> <li>d) Provison of timers for high bay lighting on/off in auto mode</li> <li>e) Up gradation of digital drive.</li> </ul>					
Picture/ sketch/ drawing before modification(if available).			Picture/ sketch/ drawing after modification		
Agency that executed the project (with complete address and email): In house efforts					
Total investment, Rs.:			Year of implementation: 2006		
First year energy cost savings, Rs.: 29.47 Lakhs					
First year other savings, Rs.:					
On annual basis	kWh 000'	Coal (Tons)	Gas Nm <sup>3</sup>	Oil (kL)	Other
Energy consumption before	130392				
Energy consumption after	129212				
Energy tariff, Rs/ kWh/ Ton/ Nm <sup>3</sup> / kL ...	2.5				
Company complete address: Rashtiya Ispat Nigam Limited Visakhapatnam Steel Plant Visakhapatnam 530032 Contact person who could be contacted for more information: <b>B K Prabhu</b> General Manager(Utilities)				We authorise Bureau to use this information for dissemination  Signature  Date	

## Energy Conservation Measure implemented in 2006-2007

(To be filled up separately for each Energy Conservation Measure)

ID to be filled by BEE	Title of the measure Reducing thermal energy consumption at MMSM Reheating furnace	Sector Iron & Steel			
Year to be filled by BEE		Technology Thermal			
<p>Description of the energy conservation measure: The blooms are reheated in reheating furnace in MMSM for further rolling into angles, channels, rounds etc. The rolling rate is dependent upon the product. Production of angles and channels is characterized by low rolling rates. Low rolling rates not only result in sub optimal utilization of furnace but also increase specific heat consumption. Hot air venting also takes place due to high furnace temperature. It was observed that heat loss through flue gas and cooling water is more than designed. Specific heat consumption at MMSM reduced by</p> <ul style="list-style-type: none"> <li>○ adopting better operation control measures.</li> <li>○ Optimization of furnace temperature during rolling and non-rolling times.</li> <li>○ Optimization of double furnace operation with respect to product mix.</li> <li>○ Improving waste heat recovery by replacing gas recuperators during capital repairs.</li> <li>○ Reducing air infiltration by repair of water troughs of the reheating furnace.</li> </ul>					
Picture/ sketch/ drawing before modification(if available)			<p style="text-align: center;"><b>Picture/ sketch/ drawing after modification</b></p> <div style="text-align: center;">  </div>		
Agency that executed the project (with complete address and email): In house efforts					
Total investment, Rs.:			Year of implementation: 2006		
First year energy cost savings, Rs.: 35.39 Lakhs					
First year other savings, Rs.:					
On annual basis	kWh 000'	Coal (Tons)	Gas Lakh Nm <sup>3</sup>	Oil (kL)	Other Mcal/t
Energy consumption before			1933		
Energy consumption after			1893		
Energy tariff, Rs/ kWh/ Ton/ Nm <sup>3</sup> / kL ...			0.85		
Company complete address: Rashtiya Ispat Nigam Limited Visakhapatnam Steel Plant Visakhapatnam 530032 Contact person who could be contacted for more information: <b>B K Prabhu</b> General Manager(Utilities)				We authorise Bureau to use this information for dissemination  Signature  Date	



## Energy Conservation Measure implemented in 2006-2007

(To be filled up separately for each Energy Conservation Measure)

ID to be filled by BEE	Title of the measure Reducing Electrical Energy consumption at MMSM	Sector Iron & Steel			
Year to be filled by BEE		Technology Electrical			
<p>Description of the energy conservation measure: Electricity is consumed in rolling drives of MMSM fro rolling blooms in to anlges,channels,rounds and billets. MMSM consumes about 3-4% of total electric energy consumption. Electrical energy consumption in MMSM is reduced by undertaking following measures.</p> <ul style="list-style-type: none"> <li>Reducing idle running of equipment</li> <li>Installation of frequency converters for roller tables</li> <li>Stopping of ventilation fans</li> <li>Energy saver for street lighting.</li> </ul>					
Picture/ sketch/ drawing before modification(if available).		Picture/ sketch/ drawing after modification			
					
Agency that executed the project (with complete address and email): In house efforts					
Total investment, Rs.:			Year of implementation: 2006		
First year energy cost savings, Rs.: 16.29 Lakhs					
First year other savings, Rs.:					
On annual basis	kWh 000'	Coal (Tons)	Gas Nm <sup>3</sup>	Oil (kL)	Other
Energy consumption before	100892				
Energy consumption after	100240				
Energy tariff, Rs/ kWh/ Ton/ Nm <sup>3</sup> / kL ...	2.5				
Company complete address: Rashtiya Ispat Nigam Limited Visakhapatnam Steel Plant Visakhapatnam 530032 Contact person who could be contacted for more information: <b>B K Prabhu</b> General Manager(Uilities)				We authorize Bureau to use this information for dissemination  Signature  Date	

## Energy Conservation Measure implemented in 2006-2007

(To be filled up separately for each Energy Conservation Measure)

ID to be filled by BEE	Title of the measure Installation of VVVF drive for CDCP-2 Ventilation fan	Sector Iron & Steel			
Year to be filled by BEE		Technology Electrical			
<p><b>Description of the energy conservation measure:</b>                  Hot incandescent coke pushed out from coke ovens is dry cooled in CDCP chambers and cooled coke is discharged on to CSP Conveyors. During discharging ,huge dust emissions is generated at woods,which is sucked by a ventilation fan to prevent dust pollution in the work area. The ventilation system is operated damper in position to control and regulate the flow. Most of the time the fan is required to run at partial load requiring the inlet damper position to be kept at 60%. Flow control through damper position is inherently energy inefficient. The VVVF drive was installed and the inlet damper was removed. Based on the flow requirement, the fan being operated at 800 RPM instead of 1000 RPM.Installation of VVVF as obviated the need for operating damper and electrical consumption reduced significantly.</p>					
<p><b>Picture/ sketch/ drawing before modification</b> (if available)</p>		<p style="text-align: center;"><b>Picture/ sketch/ drawing after modification</b></p> 			
Agency that executed the project (with complete address and email): In house efforts					
Total investment, Rs.: 5.0 lakhs	Year of implementation: 2006				
First year energy cost savings, Rs.:5.03 Lakhs					
First year other savings, Rs.:					
On annual basis	kWh 000'	Coal (Tons)	Gas Nm <sup>3</sup>	Oil (kL)	Other
Energy consumption before	957				
Energy consumption after	756				
Energy tariff, Rs/ kWh/ Ton/ Nm <sup>3</sup> / kL ...	2.50				
Company complete address: Rashtiya Ispat Nigam Limited Visakhapatnam Steel Plant Visakhapatnam 530032 Contact person who could be contacted for more information: <b>B K Prabhu</b> General Manager(Utilities)				We authorise Bureau to use this information for dissemination  Signature  Date	



## Energy Conservation Measure implemented in 2006-2007

(To be filled up separately for each Energy Conservation Measure)

ID to be filled by BEE	Title of the measure Improving the illumination of shop floor during day time by replacing with Polycarbonate sheets	Sector Iron & Steel			
Year to be filled by BEE		Technology Electrical			
<p>Description of the energy conservation measure:</p> <p>The buildings and conveyor galleries of Coke sorting plant are fixed with sodium vapor lamps at 200 locations. This lighting consumes significant amount of electrical energy. These galleries were fixed with translucent sheets made of polycarbonate material replacing the Corrugated Galvanised Iron sheets of roof at few locations. The illumination level with glowing of Sodium Vapour lamps at galleries and buildings of CSP was measured to be 59-60 lumens on an average which is conforming to safety standard. The illumination level was improved to 150-200 lumens after fixing translucent sheets. 25 CGI sheets were replaced at different locations in CCS-1 building at roof and claddings. 30 Nos of Sodium Vapour lamps were switched off in day time due to higher levels of illumination.</p>					
<p><b>Picture/ sketch/ drawing before modification</b> (if available)</p>			<p><b>Picture/ sketch/ drawing after modification</b></p> <div style="text-align: center;">  </div>		
Agency that executed the project (with complete address and email): In house efforts					
Total investment, Rs.: 0.44 lakhs			Year of implementation: 2006		
First year energy cost savings, Rs.: 0.175 Lakhs					
First year other savings, Rs.:					
On annual basis	kWh 000'	Coal (Tons)	Gas Nm <sup>3</sup>	Oil (kL)	Other
Energy consumption before	21				
Energy consumption after	14				
Energy tariff, Rs/ kWh/ Ton/ Nm <sup>3</sup> / kL ...	2.5				
<p>Company complete address: Rashtiya Ispat Nigam Limited Visakhapatnam Steel Plant Visakhapatnam 530032</p> <p>Contact person who could be contacted for more information: <b>B K Prabhu</b> General Manager(Uilities)</p>				<p>We authorise Bureau to use this information for dissemination</p> <p>Signature</p> <p>Date</p>	

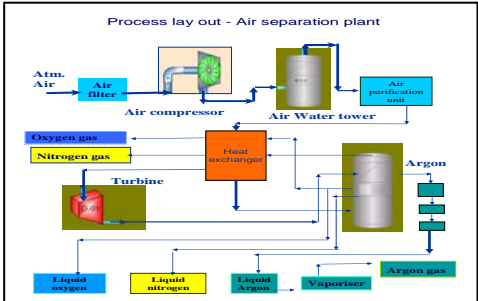

## Energy Conservation Measure implemented in 2006-2007

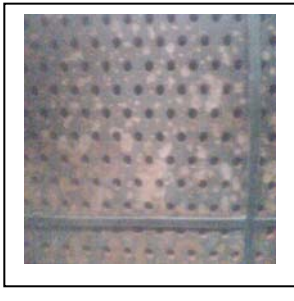
(To be filled up separately for each Energy Conservation Measure)

ID to be filled by BEE	Title of the measure Reduction of specific power consumption at ASP	Sector ...Iron & steel.			
Year to be filled by BEE		Technology Electrical			
<p>Description of the energy conservation measure:</p> <p>In air separation plant, oxygen, Nitrogen and argon are separated by processing air. The ASP is equipped with Feed air compressors of 105000 Ncum/hr air handling capacity. The total power consumption is around 925 MWH/day (average) out of which Oxygen compressors consume around 20% of the total power consumed i.e. approximately 170 mwh/day. The oxygen is consumed in steel making process at LD converter and oxygen enrichment of cold blast. The demand of oxygen is varying based on requirement at SMS and BF. Normally 3 Oxygen compressors will be running to cater the oxygen demand to SMS, BF enrichment and other autogenic needs all over the plant. The discharge pressure is varying due to varying demand at SMS &amp; BF. During two converter operation, due to low demand, it is resulting in higher discharge pressure and concomitant increase in gas temperature reducing. It is also observed that anti surge valve is opened frequently. The following activities were taken out at ASP for reducing power consumption.</p> <ol style="list-style-type: none"> <li>i. Optimised distillation process and reduced feed air compressor discharge pressure from 6.2 kg/cm<sup>2</sup> to 5.9 kh/cm<sup>2</sup>.</li> <li>ii. The suction and discharge pressures of oxygen compressors were adjusted as per the demand of SMS and BF</li> <li>iii. Maintained optimum intercooler temperatures of all centrifugal compressors</li> <li>iv. Diverted 40 kg/cm<sup>2</sup> nitrogen into 9 kg/cm<sup>2</sup> header in auto mode when nitrogen splashing compressor is in recirculation.</li> <li>v. Periodic cleaning of heat exchangers.</li> </ol>					
<b>Picture/ sketch/ drawing before modification</b>		<b>Picture/ sketch/ drawing after modification</b>			
		 			
Agency that executed the project (with complete address and email): In-house efforts					
Total investment, Rs.:			Year of implementation: 2006		
First year energy cost savings, Rs.: 109.3 Lakhs					
First year other savings, Rs.:					
On annual basis	kWh 000'	Coal (Tons)	Gas Nm <sup>3</sup>	Oil (kL)	Other
Energy consumption before	335710				
Energy consumption after	331337				
Energy tariff, Rs/ kWh/ Ton/ Nm <sup>3</sup> / kL ...	2.5				
Company complete address: Rashtiya Ispat Nigam Limited Visakhapatnam Steel Plant Visakhapatnam 530032 Contact person who could be contacted for more information: <b>B K Prabhu</b> General Manager (Utilities)				We authorize Bureau to use this information for dissemination  Signature  Date	

## Energy Conservation Measure implemented in 2006-2007

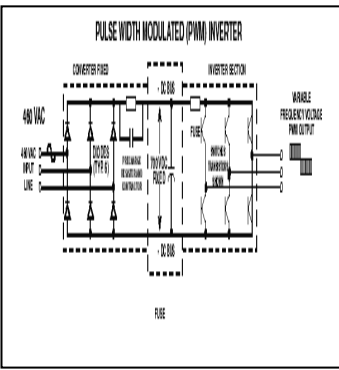
(To be filled up separately for each Energy Conservation Measure)

ID to be filled by BEE	Title of the measure Use of squirrel cage induction motor with Vector controlled drive in place of Slip Rind induction motor in wagon tippler	Sector Iron & Steel			
Year to be filled by BEE	Technology Electrical				
<p>Description of the energy conservation measure:                  There are 5 Nos of Wagon tippers ( 2 Nos for coal and 3 Nos for Ore) in RMHP running with 2*55 KW slip ring induction motor and 14 Nos of power contactors for each tippler. It is observed that the starting current is more in tippler and the power factor is also low. The maintenance and spares requirement for motor and control panel is more. It is possible to get desired torque and accurate speed control with squirrel cage induction motor with Vector Controlled Drive. Installation of Vector control drive with Squirrel cage induction motor(55KW) reduced power consumption by 20% per rake and reduced motor failures.</p>					
<p><b>Picture/ sketch/ drawing before modification</b> (if available)</p> <div style="border: 1px solid black; width: 100%; height: 100%; text-align: center;">  </div>		<p><b>Picture/ sketch/ drawing after modification</b></p> <div style="display: flex; justify-content: space-around;"> <div style="border: 1px solid black; width: 45%; text-align: center;">  </div> <div style="border: 1px solid black; width: 45%; text-align: center;">  </div> </div>			
Agency that executed the project (with complete address and email): In house efforts					
Total investment, Rs.: 4 lakhs			Year of implementation:2006		
First year energy cost savings, Rs.: 0.53					
First year other savings, Rs.:					
On annual basis	kWh 000'	Coal (Tons)	Gas Nm <sup>3</sup>	Oil (kL)	Other
Energy consumption before	105.5				
Energy consumption after	84.46				
Energy tariff, Rs/ kWh/ Ton/ Nm <sup>3</sup> / kL ...	2.5				
Company complete address: Rashtiya Ispat Nigam Limited Visakhapatnam Steel Plant Visakhapatnam 530032 Contact person who could be contacted for more information: <b>B K Prabhu</b> General Manager(Utilities)				We authorise Bureau to use this information for dissemination  Signature  Date	

**Energy Conservation Measure implemented in 2006-2007**  
(To be filled up separately for each Energy Conservation Measure)

ID to be filled by BEE	Title of the measure Improving air conditioning system in LMMM ECR-1	Sector Iron & Steel			
Year to be filled by BEE		Technology Electrical			
<p>Description of the energy conservation measure: There are 9 nos of Air handling units in LMMM Electrical Control Room -1 of Bar Mill for supplying conditioned air with total TR of 297 . These AHUS are equipped with 5.5 KW motors for driving the fan . It is observed that actual TR required for hall is 120 TR at temperature of 27<sup>0</sup>c. It is observed that these AHU's are running at very low efficiency due to location of 2 Nos of AHU's at +0 m level and higher length of duct. The design air flow is very less as compared to AHU capacity. The present fan type was forward curved fan and it was replaced with Backward curved fan which are efficient than former. Instead of 9 AHU's are running, 4 AHU's were running with improved flow and conditioned air. Installation of new AHU's resulted in stopping of 5 AHUs and reduced power consumption.</p>					
<b>Picture/ sketch/ drawing before modification</b> (if available)			<b>Picture/ sketch/ drawing after modification</b>		
Agency that executed the project (with complete address and email): In house efforts					
Total investment, Rs.:10.5 lakhs			Year of implementation: 2006		
First year energy cost savings, Rs.: 5.79 Lakhs					
First year other savings, Rs.:					
On annual basis	kWh 000'	Coal (Tons)	Gas Nm <sup>3</sup>	Oil (kL)	Other
Energy consumption before	477				
Energy consumption after	245				
Energy tariff, Rs/ kWh/ Ton/ Nm <sup>3</sup> / kL ...	2.5				
Company complete address: Rashtiya Ispat Nigam Limited Visakhapatnam Steel Plant Visakhapatnam 530032 Contact person who could be contacted for more information: <b>B K Prabhu</b> General Manager(Uilities)				We authorise Bureau to use this information for dissemination  Signature  Date	



## Energy Conservation Measure implemented in 2006-2007

(To be filled up separately for each Energy Conservation Measure)

ID to be filled by BEE	Title of the measure Improving air conditioning system in MMSM, Central supervisory control room		Sector Iron & Steel		
Year to be filled by BEE			Technology Electrical		
<p>Description of the energy conservation measure:                  The central supervisory control room of MMSM is equipped with Air Handling system for supplying conditioned air at temperature of 28<sup>0</sup>c . The AHU is equipped with forward curved centrifugal fan of 13500 cum/hr and driven by 5.5 KW .The Cooling capacity of Air handling system was 33 TR. It was observed that the design air flow is very less as compared to AHU capacity and the actual TR requirement was 20-25 TR as compared to design TR of 33. Due to oversize of the system, it was running at low efficiency. The fan was replaced with backward curved type and the motor of lower capacity(3.7 KW) was installed. Installation of new system reduced power consumption and temperature and air flow was improved.</p>					
Picture/ sketch/ drawing before modification(if available).			Picture/ sketch/ drawing after modification		
Agency that executed the project (with complete address and email): In house efforts					
Total investment, Rs.: 2.7 lakhs			Year of implementation: 2006		
First year energy cost savings, Rs.:0.39 lakhs					
First year other savings, Rs.:					
On annual basis	kWh 000'	Coal (Tons)	Gas Nm <sup>3</sup>	Oil (kL)	Other
Energy consumption before	48				
Energy consumption after	32				
Energy tariff, Rs/ kWh/ Ton/ Nm <sup>3</sup> / kL ...	2.5				
Company complete address: Rashtiya Ispat Nigam Limited Visakhapatnam Steel Plant Visakhapatnam 530032 Contact person who could be contacted for more information: <b>B K Prabhu</b> General Manager(Utilities)				We authorize Bureau to use this information for dissemination  Signature  Date	

## Energy Conservation Measure implemented in 2006-2007

(To be filled up separately for each Energy Conservation Measure)

ID to be filled by BEE	Title of the measure Replacement of Four No. of existing fan blades of CT-16 & 17 with Recondo make or equivalent blades	Sector Iron & Steel			
Year to be filled by BEE		Technology Electrical			
Description of the energy conservation measure:					
<p>The Pump house –4 meets water requirements of Captive power plants.. The Cooling Tower-16 is operated by cooling tower fan which are driven by 16 KW motors. The effectiveness of cooling tower is less due to the inherent nature of glass reinforced blades due to its high weight. The torque requirements are very high .</p> <p>Existing glass reinforced fan blades are replaced with Recondo make (Fiber Resistant Plastic ) fan blades. . About 19 fans were replaced with Recondo make (FRP) fan blades. The air velocity improved from 6.5 to 6.9 m/sec and operating current reduced from 100 Amps to 95 Amps.Above activity resulted in reduction of motor load and reduced electricity consumption.</p>					
Picture/ sketch/ drawing before modification (if available).			Picture/ sketch/ drawing after modification		
					
Agency that executed the project (with complete address and email):					
Total investment, Rs.:			Year of implementation: 2006		
First year energy cost savings, Rs.:66.57 Lakhs					
First year other savings, Rs.:					
On annual basis	kWh 000'	Coal (Tons)	Gas Nm <sup>3</sup>	Oil (kL)	Other
Energy consumption before	10982				
Energy consumption after	8319				
Energy tariff, Rs/ kWh/ Ton/ Nm <sup>3</sup> / kL ...	2.5				
Company complete address: Rashtiya Ispat Nigam Limited Visakhapatnam Steel Plant Visakhapatnam 530032 Contact person who could be contacted for more information: <b>B K Prabhu</b> General Manager(Uilities)				We authorise Bureau to use this information for dissemination  Signature  Date	

## Energy Conservation Measure implemented in 2006-2007

(To be filled up separately for each Energy Conservation Measure)

ID to be filled by BEE	Title of the measure Installation of 40 KVA energy savers at PH-11,16 & 18	Sector Iron & Steel			
Year to be filled by BEE		Technology Electrical			
<p>Description of the energy conservation measure: There are 40 Nos of Street Light Fitting of HPSV 400 watt for illuminating the Pump House 11,16 &amp; 18. 40 KVA energy savers were installed in above places. There is provision to change the voltage. Accordingly, each light fitting will get 230 V AC from 6 PM to 11:30 PM and afterwards the supply will come down to 194 V. Installation of above system reduced electricity consumption by 20%. The Load current reduced from 30 A to 22 A with installation of Energy saver at PH 11 and 40 Amps to 26 Amps at PH-18.</p>					
<b>Picture/ sketch/ drawing before modification</b> (if available)			<b>Picture/ sketch/ drawing after modification</b>		
					
Agency that executed the project (with complete address and email): In house efforts					
Total investment, Rs.: 1.64 lakhs			Year of implementation: 2006		
First year energy cost savings, Rs.:0.495 Lakhs					
First year other savings, Rs.:					
On annual basis	kWh 000'	Coal (Tons)	Gas Nm <sup>3</sup>	Oil (kL)	Other
Energy consumption before	62.7				
Energy consumption after	42.9				
Energy tariff, Rs/ kWh/ Ton/ Nm <sup>3</sup> / kL ...	2.5				
Company complete address: Rashtiya Ispat Nigam Limited Visakhapatnam Steel Plant Visakhapatnam 530032 Contact person who could be contacted for more information: <b>B K Prabhu</b> General Manager(Uilities)				We authorise Bureau to use this information for dissemination  Signature  Date	

## Energy Conservation Measure implemented in 2006-2007

(To be filled up separately for each Energy Conservation Measure)

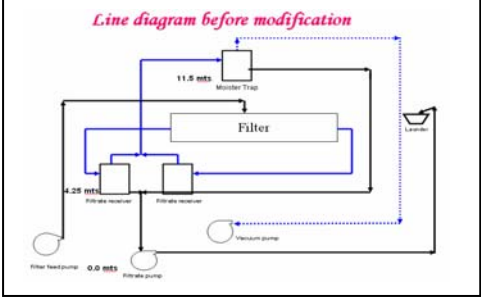
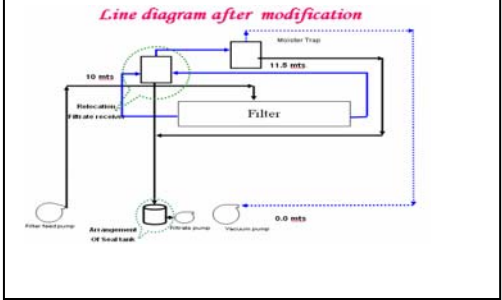
ID to be filled by BEE	Title of the measure Reducing Number of Vacuum pumps running at Treatment Plant-3	Sector Iron & Steel			
Year to be filled by BEE		Technology Electrical			
<p>Description of the energy conservation measure:</p> <p>Three numbers of Vacuum drum filters were provided in Steel melting shop treatment plant to recover the solids from SMS Gas cleaning Plant water circuit. There are 6 Nos of vacuum pumps provided to maintain 540 mm HG vacuum at filters. Vacuum is required to dry the cake. It was observed that the vacuum developed is only 300 mm HG in spite of running 3 Nos though it is envisaged to run two pumps only and the overall efficiency of drum filter was very low.</p> <p>The filtrate from the vacuum drum filters is collected in Filtrate receivers which are located at a height of 4.25 meters above vacuum pumps. When drum filter started a fresh, vacuum was maintained around 500 mm HG for some time and vacuum is falling drastically after few minutes. It is observed that the static head on account of locating filtrate receiver at 4.25 M level is more than required and it is not allowing free fall. Due to above problem, water was getting accumulated in filtrate receivers and blocking the connected pipes there by vacuum at filtrate drum falling drastically.</p> <p>To overcome above problem, static head of water column receiver is increased by relocating the 10 meter heights and a seal tank is provided at bottom. With this modification, filtrate from receivers is falling freely in to seal tank, there by vacuum at drum filter is maintained more than 550 mmhg and 2 pumps sufficient for running drum filters against 6 pumps earlier. With this modification, filter cake thickness has increased and it is getting dried up very effectively. Overall drum efficiency has improved, there by total solids of SMS GCP water circuit can be recovered by running two filters in two shifts per day.</p>					
<b>Picture/ sketch/ drawing before modification</b> (if available)			<b>Picture/ sketch/ drawing after modification</b>		
					
Agency that executed the project (with complete address and email): In house efforts					
Total investment, Rs.:			Year of implementation: 2006		
First year energy cost savings, Rs.: 59.1 Lakhs					
First year other savings, Rs.:					
On annual basis	kWh 000'	Coal (Tons)	Gas Nm <sup>3</sup>	Oil (kL)	Other
Energy consumption before	3548				
Energy consumption after	1183				
Energy tariff, Rs/ kWh/ Ton/ Nm <sup>3</sup> / kL ...	2.5				
Company complete address: Rashtiya Ispat Nigam Limited Visakhapatnam Steel Plant Visakhapatnam 530032 Contact person who could be contacted for more information: <b>B K Prabhu</b> General Manager(Uilities)				We authorise Bureau to use this information for dissemination  Signature  Date	



## Energy Conservation Measure implemented in 2006-2007

(To be filled up separately for each Energy Conservation Measure)

ID to be filled by BEE	Title of the measure Improving Productivity at MMSM and reducing wastage of chilled water at Electrical Control rooms of MMSM				Sector Iron & Steel	
Year to be filled by BEE					Technology Air Conditioning	
<b>Description of the energy conservation measure:</b>						
<p>The blooms are rolled into angles and structurals in MMSM . The Mill process control is carried out by Programmable Logic controllers . The PLC panels are located in the electrical rooms of MMSM . These Electrical Control rooms are equipped with air conditioning system using chilled water to maintain the electronic systems at regulated temperature. It is observed that effective cooling is not taking place for fluctuation in tank level of return water ,frequent air locking of pumps resulting frequent failure of electronic cards. The production is affected by failure of electronic card. It is observed that the tank overflow takes place due to lack adequate facilities for measuring tank level. It is observed that 480 Cum of chilled water is lost to due to overflow. After carrying out brain storming, level control system was installed and continuous control of level was maintained. Due to above modification, the chilled water reliability improved and the failure of electronic cards reduced . Reduction in failure of electronic cards improved rolling at MMSM . Not only improvement in production, installation of level control system reduced the chilled water wastage .</p>						
<b>Picture/ sketch/ drawing before modification</b> (if available)				Picture/ sketch/ drawing after modification		
Agency that executed the project (with complete address and email): In house efforts						
Total investment, Rs.:				Year of implementation: 2006		
First year energy cost savings, Rs.: 15.8 Lakhs						
First year other savings, Rs.: 8.51 Lakhs						
On annual basis	kWh 000'	Coal (Tons)	Gas Nm <sup>3</sup>	Oil (kL)	Other	
Energy consumption before	16038					
Energy consumption after	15406					
Energy tariff, Rs/ kWh/ Ton/ Nm <sup>3</sup> / kL	2.5					
Company complete address: Rashtiya Ispat Nigam Limited Visakhapatnam Steel Plant Visakhapatnam 530032				We authorize Bureau to use this information for dissemination		
Contact person who could be contacted for more information: <b>B K Prabhu</b> General Manager(Utilities)				Signature		
				Date		

## Energy Conservation Measure implemented in 2006-2007

(To be filled up separately for each Energy Conservation Measure)

ID to be filled by BEE	Title of the measure Energy Saver for Street Lighting in MMSM Area Shop Office	Sector Iron & Steel			
Year to be filled by BEE		Technology Electrical			
<p>Description of the energy conservation measure: There are 40 Nos of Street Light Fitting of HPSV 400 watt for illuminating the main road in front of MMSM Area Shop Office. One 40 KVA energy saver was installed in the above system. There is provision to change the voltage. Accordingly, each light fitting will get 230 V AC from 6 PM to 11:30 PM and afterwards the supply will come down to 194 V. Installation of above system reduced electricity consumption by 20%. The Load current reduced from 25.7 A to 20.7 A with installation of Energy saver.</p>					
Picture/ sketch/ drawing before modification.(if available).			<b>Picture/ sketch/ drawing after modification</b>		
					
Agency that executed the project (with complete address and email): In house efforts					
Total investment, Rs.:			Year of implementation: 2006		
First year energy cost savings, Rs.:0.38 lakhs					
First year other savings, Rs.:					
On annual basis	kWh 000'	Coal (Tons)	Gas Nm <sup>3</sup>	Oil (kL)	Other
Energy consumption before	76.2				
Energy consumption after	60.9				
Energy tariff, Rs/ kWh/ Ton/ Nm <sup>3</sup> / kL ...	2.5				
Company complete address: Rashtiya Ispat Nigam Limited Visakhapatnam Steel Plant Visakhapatnam 530032 Contact person who could be contacted for more information: <b>B K Prabhu</b> General Manager(Uilities)				We authorise Bureau to use this information for dissemination  Signature  Date	

## Energy Conservation Measure implemented in 2006-2007

(To be filled up separately for each Energy Conservation Measure)

ID to be filled by BEE	Title of the measure Energy Savers in Engineering Shops	Sector Iron & Steel			
Year to be filled by BEE		Technology Electrical			
<p>Description of the energy conservation measure: High bay lighting comprises of major lighting load of all units of Engineering shops. Since these shops are operated in batches, there is scope for reducing electrical energy during non working period. Energy savers 90 KVA,60 KVA,40 KVA were installed in Central Machine shop, Foundry and Utility equipment Repair Shop .Installation of 5 Energy Savers in above shops reduced electrical energy consumption by 472 KWH per day.</p>					
Picture/ sketch/ drawing before modification(if available).		Picture/ sketch/ drawing after modification			
					
Agency that executed the project (with complete address and email): In house efforts					
Total investment, Rs.:4.0 Lakhs			Year of implementation: 2006		
First year energy cost savings, Rs.:4.31 lakhs					
First year other savings, Rs.:					
On annual basis	kWh 000'	Coal (Tons)	Gas Nm <sup>3</sup>	Oil (kL)	Other
Energy consumption before	734.9				
Energy consumption after	562.5				
Energy tariff, Rs/ kWh/ Ton/ Nm <sup>3</sup> / kL ...	2.5				
Company complete address: Rashtiya Ispat Nigam Limited Visakhapatnam Steel Plant Visakhapatnam 530032 Contact person who could be contacted for more information: <b>B K Prabhu</b> General Manager(Utilities)				We authorise Bureau to use this information for dissemination  Signature  Date	

## Energy Conservation Measure implemented in 2006-2007

(To be filled up separately for each Energy Conservation Measure)

ID to be filled by BEE	Title of the measure Recycling of Tar sludge in to coke ovens		Sector Iron & Steel			
Year to be filled by BEE			Technology Thermal			
<p>Description of the energy conservation measure:</p> <p>During Coke making process, volatile matter present in the coal becomes coke oven gas. While cooling coke oven gas, tar present in the gas is condensed in hydraulic main, Primary Gas Cooler &amp; Electro Static Precipitator. Tar separated in Decanters is called tar sludge. In tar storage tank, sludge settles down and deposited at the bottom. Every year the sludge is cleaned from the storage tank.</p> <p>The tar sludge was dumped beyond tar plant boundary, which is causing land degradation. Since it contains carbon, it can be used in coke oven along with coal charge. Tar sludge is dumped near Yard-2 conveyor. The Yard-2 conveyor charges coal into coke oven. A connection was made to Yard-2 conveyor with inclined conveyor. Tar sludge is charged to the inclined conveyor, which feeds to the yard – 2 conveyor carrying coal. About 1734 tons of Tar sludge is recycled in to coke oven batteries and replaced Coking coal to the extent of 1734 tons</p>						
Picture/ sketch/ drawing before modification (if available).			<b>Picture/ sketch/ drawing after modification</b>			
Agency that executed the project (with complete address and email): In house efforts						
Total investment, Rs.:			Year of implementation: 2006			
First year energy cost savings, Rs.: 97.38 Lakhs						
First year other savings, Rs.:						
On annual basis	kWh 000'	Coal (Tons)	Gas Nm <sup>3</sup>	Oil (kL)	Other	
Energy consumption before		1734				
Energy consumption after		0				
Energy tariff, Rs/ kWh/ Ton/ Nm <sup>3</sup> / kL /Kg...		5.6				
Company complete address: Rashtiya Ispat Nigam Limited Visakhapatnam Steel Plant Visakhapatnam 530032 Contact person who could be contacted for more information: <b>B K Prabhu</b> General Manager(Uilities)				We authorize Bureau to use this information for dissemination  Signature  Date		

## Energy Conservation Measure implemented in 2006-2007

(To be filled up separately for each Energy Conservation Measure)

ID to be filled by BEE	Title of the measure Recycling of Benzol muck, coke dust, ASP sludge and MBC sludge in to coke ovens	Sector Iron & Steel			
Year to be filled by BEE		Technology Thermal			
<p>Description of the energy conservation measure:</p> <p>Benzol is recovered by absorbing it in solar oil in the Benzol scrubber, where solar oil is circulated counter current to coke oven gas flow. Benzol is separated from solar oil by steam stripping and debenzolised oil is recirculated to Benzol scrubber. During this process lot of muck is generated which is separated in the decanter and is disposed. Benzol muck is highly polymerized material in slurry form. Usage of Benzol muck in coke oven battery will avoid land degradation. Due to slurry nature of the muck, it cannot be added to coal. Benzol muck was mixed with coke dust and then added on coal carrying conveyor Y-2. To reduce the oil content in the muck, separate muck drying beds (3Nos) were made and the muck was allowed to dry for a period of one week. After removal of oil, the muck was taken to Y-2 conveyor area, mixed with coke dust, and charged on Y-2 conveyor along with coal. 13451 tons of benzol muck and coke dust sludge, ASP sludge and MBC sludge was recycled in to coke oven batteries and replaced coal to the extent of 13855 tons</p>					
Picture/ sketch/ drawing before modification (if available).		Picture/ sketch/ drawing after modification			
Agency that executed the project (with complete address and email): In house efforts					
Total investment, Rs.:			Year of implementation: 2006		
First year energy cost savings, Rs.: 778.0 Lakhs					
First year other savings, Rs.:					
On annual basis	kWh 000'	Coal (Tons)	Gas Nm <sup>3</sup>	Oil (kL)	Other
Energy consumption before		13855			
Energy consumption after		0			
Energy tariff, Rs/ kWh/ Ton/ Nm <sup>3</sup> / kL ...		5.6			
Company complete address: Rashtiya Ispat Nigam Limited Visakhapatnam Steel Plant Visakhapatnam 530032 Contact person who could be contacted for more information: <b>B K Prabhu</b> General Manager(Utilities)				We authorise Bureau to use this information for dissemination  Signature  Date	

## Energy Conservation Measure implemented in 2006-2007

(To be filled up separately for each Energy Conservation Measure)

ID to be filled by BEE	Title of the measure Reducing electricity consumption by replacing vibrofeeders with Vibratory tube feeders(with unbalanced motors) for product bunker No.6 at Flux storage bins of CRMP	Sector Iron & Steel			
Year to be filled by BEE		Technology Electrical			
<p>Description of the energy conservation measure:</p> <p>Calcined lime is used as fluxing agent at LD converter for production of steel. The lime is produced at Calcination and Refractory Materials plant thro decomposition of lime stone in Lime kiln. The Flux is transported from Flux storage bins to Steel Melting Shop by CO-95 to CO-99 conveyors thro' Vibro feeders. There are eight product bins and flux demand is about 200-250 tons. These vibratory feeders and conveyors 95-99 were to run for three hours every shift. An electromagnetic Vibro feeder of 1.5 KW is installed with bunker. The bunker capacity is 80t.</p> <p>It is observed that the discharge rate thro' bunkers is 25tph. Therefore ,the vibratory feeder and conveyors are to be operated for 7.5 hours per day. The Vibratory feeders are activated by vibrations through electromagnetic core . Due to its inherent nature and electrical losses are very high. Since the vibrations through existing electro magnetic core, it is effective to use two unbalanced motors of 1.2 KW capacity as the discharge rate can be increased. Increasing discharge rate from 25 tph to 100 tph reduce running time of conveyors.The Twin unbalanced motors were installed on Product Bin No.6 of FSB. It has reduced running hours of conveyors from 7.5 hours to 3 hours. It has reduced power consumption by 228 KWhr/day and resulted in electrical energy savings of 83220 KWh per year.</p>					
Picture/ sketch/ drawing before modification (if available).			<p style="text-align: center;"><b>Picture/ sketch/ drawing after modification</b></p> <div style="text-align: center;">  </div>		
Agency that executed the project (with complete address and email):					
Total investment, Rs.:			Year of implementation:		
First year energy cost savings, Rs.:					
First year other savings, Rs.:					
On annual basis	kWh 000'	Coal (Tons)	Gas Nm <sup>3</sup>	Oil (kL)	Other
Energy consumption before	164.250				
Energy consumption after	821.25				
Energy tariff, Rs/ kWh/ Ton/ Nm <sup>3</sup> / kL ...					
Company complete address: Rashtiya Ispat Nigam Limited Visakhapatnam Steel Plant Visakhapatnam 530032 Contact person who could be contacted for more information: <b>B K Prabhu</b> General Manager(Utilities)				We authorise Bureau to use this information for dissemination  Signature  Date	

## Energy Conservation Measure implemented in 2006-2007

(To be filled up separately for each Energy Conservation Measure)

ID to be filled by BEE	Title of the measure Reducing electricity consumption at CRMP by replacing the DC Motors in VVFD for weight feeders No.6 & 7 at LSDS	Sector Iron & Steel			
Year to be filled by BEE		Technology Electrical			
<p>Description of the energy conservation measure:</p> <p>The Lime stone and Dolomite are transported to stone bins every shift from LSDS storage Bins No. 5&amp;6 through weigh feeders No.6&amp;7 via CO1A1 and CO1a2 conveyors. There are 5 stobe bins and about 450 tons of Lime stone and dolomite is transported. The weigh feeders 6&amp;7 run continuously for three hours every shift. Since these weigh feeders are equipped with old DC motors and it was replaced with Variable Voltage and Variable frequency drives. The load on motor is reduced and the running of CO1A1 and CO1a2 was reduced from four hours to three hours. This project resulted in electrical energy savings of 81030 KW in the year 2006-07.</p>					
Picture/ sketch/ drawing before modification (if available).	Picture/ sketch/ drawing after modification				
					
Agency that executed the project (with complete address and email): In house efforts					
Total investment, Rs.:	Year of implementation: 2006				
First year energy cost savings, Rs.: 1.53 Lakhs					
First year other savings, Rs.:					
On annual basis	kWh 000'	Coal (Tons)	Gas Nm <sup>3</sup>	Oil (kL)	Other
Energy consumption before	246.3				
Energy consumption after	185.0				
Energy tariff, Rs/ kWh/ Ton/ Nm <sup>3</sup> / kL ...	2.5				
Company complete address: Rashtiya Ispat Nigam Limited Visakhapatnam Steel Plant Visakhapatnam 530032 Contact person who could be contacted for more information: <b>B K Prabhu</b> General Manager(Utilities)				We authorise Bureau to use this information for dissemination  Signature  Date	

## Energy Conservation Measure implemented in 2006-2007

(To be filled up separately for each Energy Conservation Measure)

ID to be filled by BEE	Title of the measure Usage of LD Slag in sinter & Iron making		Sector Iron & Steel		
Year to be filled by BEE			Technology Thermal		
<p>Description of the energy conservation measure:                  LD slag is produced in the process of steel making .LD slag constitutes useful materials like Cao, Feo and others. As the amount of slag produced is considerable, solid waste management is of crucial importance.. Usage of LD slag is aimed at replacing lime stone. Lime stone is used in sinter making as fluxes and requires energy for dissociation. Usage of LD slag in Sinter making reduce the energy for dissociation of lime stone. As LD slag contains Cao, it can replace the lime stone and lime fines requirement.. The LD slag has to be transported to Sinter Plant base mix yard by trucks. About 80666 t of LD slag was recirculated. This has resulted in replacing limestone. Usage of LD slag resulted in annualised energy savings of 68566 cal and reduced coke breeze requirement of 10083 tons annual. This project resulted in annualized financial savings of Rs. 519 lakhs for the year 2006-07.</p>					
Picture/ sketch/ drawing before modification (if available).			<b>Picture/ sketch/ drawing after modification</b>		
Agency that executed the project (with complete address and email): In house efforts					
Total investment, Rs.:			Year of implementation: 2006		
First year energy cost savings, Rs.: 519 Lakhs					
First year other savings, Rs.:					
On annual basis	kWh 000'	Coke breeze (Tons)	Gas Nm <sup>3</sup>	Oil (kL)	Other
Energy consumption before		10083			
Energy consumption after		0			
Energy tariff, Rs/ kWh/ Ton/ Nm <sup>3</sup> / kL ...		5.15			
Company complete address: Rashtiya Ispat Nigam Limited Visakhapatnam Steel Plant Visakhapatnam 530032 Contact person who could be contacted for more information: <b>B K Prabhu</b> General Manager(Utilities)				We authorise Bureau to use this information for dissemination  Signature  Date	

## Energy Conservation Measure implemented in 2006-2007

(To be filled up separately for each Energy Conservation Measure)

ID to be filled by BEE	Title of the measure Increase in Blast temperature in Blast Furnaces		Sector Iron & Steel		
Year to be filled by BEE			Technology Thermal		
<p>Description of the energy conservation measure:</p> <p>The heat requirement for blast furnace is met by heating cold blast through Blast Furnace stoves to rise the temperature from 100 deg.c to 1020 deg.c. The temperature of the blast burns coke in the blast furnace. Increase in Hot blast temperature increases the raceway adiabatic flame temperature (RAFT) in the blast furnace. Higher RAFT in the furnace results in effective combustion of coke. To achieve higher blast temperature requires increasing the BF stoves efficiency. The following activities were undertaken to increase blast temperature</p> <ul style="list-style-type: none"> <li>Increased the dome temperature in Blast furnaces by enriching with coke oven gas .</li> <li>Repairing damaged refractory in blast stoves.</li> </ul> <p>Implementation of above measures increased blast temperature in blast furnace –1 from 999 °c to 1020 °c and 1015 °c to 1022 °c . This has contributed in reducing coke rate from 533 kg/thm to 530 kg/thm in blast furnace. It has resulted in annualised energy savings of 83139 Gcals and annualised financial savings of Rs. 1096 Lakhs for the year 2006-07.</p>					
<b>Picture/ sketch/ drawing before modification (if available).</b>			<b>Picture/ sketch/ drawing after modification</b>		
Agency that executed the project (with complete address and email): In house efforts					
Total investment, Rs.:			Year of implementation: 2006		
First year energy cost savings, Rs.: 1096 lakhs					
First year other savings, Rs.:					
On annual basis	kWh 000'	BF Coke (Tons)	Gas Nm <sup>3</sup>	Oil (kL)	Other
Energy consumption before		2156356			
Energy consumption after		2144219			
Energy tariff, Rs/ kWh/ Ton/ Nm <sup>3</sup> / kL /kg ...		9.04			
Company complete address: Rashtiya Ispat Nigam Limited Visakhapatnam Steel Plant Visakhapatnam 530032 Contact person who could be contacted for more information: <b>B K Prabhu</b> General Manager(Uilities)				We authorise Bureau to use this information for dissemination  Signature  Date	

## Energy Conservation Measure implemented in 2006-2007

(To be filled up separately for each Energy Conservation Measure)

ID to be filled by BEE	Title of the measure Reducing electrical energy consumption by locating and plugging the false air leakages in to DE system no.11.1 &11.2		Sector Iron & Steel		
Year to be filled by BEE			Technology Electrical		
Description of the energy conservation measure: The Dust extraction system no.11.1 and 11.2 are evacuating the dust and fumes from Calcining Plant area. It is observed that the Fan (8.6 KW) motor is taking extra load due to leakages . Leakages were observed in the suction path . The leakages were identified and sealed at suction ducts,fan casings ,screw conveyor covers .Implementation of above measure resulted in electrical energy savings of 18834 KWH in the year 2006-07.					
<b>Picture/ sketch/ drawing before modification (if available).</b>			<b>Picture/ sketch/ drawing after modification</b>		
Agency that executed the project (with complete address and email): In house efforts					
Total investment, Rs.:			Year of implementation: 2006		
First year energy cost savings, Rs.:0.46 Lakhs					
First year other savings, Rs.:					
On annual basis	kWh 000'	Coal (Tons)	Gas Nm <sup>3</sup>	Oil (kL)	Other
Energy consumption before	69.26				
Energy consumption after	50.42				
Energy tariff, Rs/ kWh/ Ton/ Nm <sup>3</sup> / kL ...	2.5				
Company complete address: Rashtiya Ispat Nigam Limited Visakhapatnam Steel Plant Visakhapatnam 530032 Contact person who could be contacted for more information: <b>B K Prabhu</b> General Manager(Utilities)				We authorise Bureau to use this information for dissemination  Signature  Date	

## Energy Conservation Measure implemented in 2006-2007

(To be filled up separately for each Energy Conservation Measure)

ID to be filled by BEE	Title of the measure Reduction of furnace oil consumption in TPP boilers.		Sector Iron & Steel			
Year to be filled by BEE			Technology Thermal			
<p>Description of the energy conservation measure: Furnace oil is used in Thermal Power Plant boilers for ignition of boiler as well as stabilization of flame. Once the flame is stabilizes other fuel likes coke oven gas, BF gas, boiler coal are fired. During the shortage of these fuels furnace oil firing is resorted to meet steam generation requirement. Usage of furnace oil is intermittent activity and each light up of boiler consumes about 45KL of furnace oil. The following activities were taken to reduce furnace oil consumption.</p> <ul style="list-style-type: none"> <li>Reduction of boiler light up by improved operational practices</li> <li>Ensuring availability of coke oven gas to boilers.</li> </ul> <p>Implementation of above measures on continuous basis reduced furnace oil consumption from 1050 KL in year 2005-06 to 533 KL in 2006-07. This has resulted in annualized energy savings of 5066 Gcals and annualized financial savings of Rs. 72 lakhs.</p>						
Picture/ sketch/ drawing before modification (if available).			<b>Picture/ sketch/ drawing after modification</b>			
Agency that executed the project (with complete address and email): In house efforts						
Total investment, Rs.:			Year of implementation: 2006			
First year energy cost savings, Rs.: 72. 0 Lakhs						
First year other savings, Rs.:						
On annual basis	kWh 000'	Coal (Tons)	Gas Nm <sup>3</sup>	Oil (kL)	Other	
Energy consumption before				1050		
Energy consumption after				517		
Energy tariff, Rs/ kWh/ Ton/ Nm <sup>3</sup> / kL ...				13.9		
Company complete address: Rashtiya Ispat Nigam Limited Visakhapatnam Steel Plant Visakhapatnam 530032 Contact person who could be contacted for more information: <b>B K Prabhu</b> General Manager(Uilities)				We authorise Bureau to use this information for dissemination  Signature  Date		