

## ENERGY CONSERVATION MEASURE Implemented in 2006-07

ID to be filled by BEE	Title of the measure	Sector			
Year to be filled by BEE		Technology			
Description of the energy conservation measure: Heat Recovery from CBD of RG Boiler & Auxiliary Boiler-III through heating of NG Fuel to Primary Reformer IN Ammonia-II.					
Picture / Sketch / Drawing before modification	Picture / Sketch / Drawing after modification				
Agency that executed the project (With complete address and email) : In-house					
Total investment, Rs. : 4.10 Lakhs	Year of completion : 2006-07				
First year energy cost savings (anticipated),Rs.: 16.50 Lakhs					
First year other savings,Rs.:					
On annual basis	KWH 000'	Coal (Tons)	Gas Sm <sup>3</sup>	Oil (KL)	Other
Energy saved			196000		
Energy consumed after					
Energy tariff, Rs. / KWH/ Ton / Nm <sup>3</sup> /KL			Rs. 8.4 / Sm <sup>3</sup>		
Company complete address: Chambal Fertilisers and Chemicals Ltd. P.O Gadepan - 325208, District KOTA, Rajasthan				We authorize Bureau to use this information for dissemination	
Contact Person who could be contacted for more information: Mr. R. Chaba - Manager (Process) Chambal Fertilisers and Chemicals Ltd.				Signature Date	

## ENERGY CONSERVATION MEASURE Implemented in 2006-07

ID to be filled by BEE	Title of the measure	Sector			
Year to be filled by BEE		Technology			
Description of the energy conservation measure:  Repassing of Desulphuriser furnace coils from four passes to eight passes in Ammonia-II					
Picture / Sketch / Drawing before modification		Picture / Sketch / Drawing after modification			
Agency that executed the project (With complete address and email) : Basic Engg. By Technip India Limited, Detail Engg by PDIL					
Total investment, Rs. : 120 Lakhs		Year of completion : 2006-07			
First year energy cost savings (anticipated),Rs.: 150 Lakhs					
First year other savings,Rs.:					
On annual basis	KWH 000'	Coal (Tons)	Gas Sm <sup>3</sup>	Oil (KL)	Other
Energy saved			1786000		
Energy consumed after					
Energy tariff, Rs. / KWH/ Ton / Nm <sup>3</sup> /KL			Rs. 8.4 / Sm <sup>3</sup>		
Company complete address: <b>Chambal Fertilisers and Chemicals Ltd.</b> P.O Gadepan - 325208, District KOTA, Rajasthan			We authorize Bureau to use this information for dissemination		
Contact Person who could be contacted for more information: <b>Mr. R. Chaba - Manager (Process)</b> Chambal Fertilisers and Chemicals Ltd.			Signature Date		

## ENERGY CONSERVATION MEASURE Implemented in 2006-07

ID to be filled by BEE	Title of the measure	Sector
Year to be filled by BEE		Technology

Description of the energy conservation measure:

Preheating of Auxiliary Boiler-III NG fuel by saturated SL generated in AB -III CBD vessel, instead of letting down SM to SL.

Picture / Sketch / Drawing before modification

Picture / Sketch / Drawing after modification

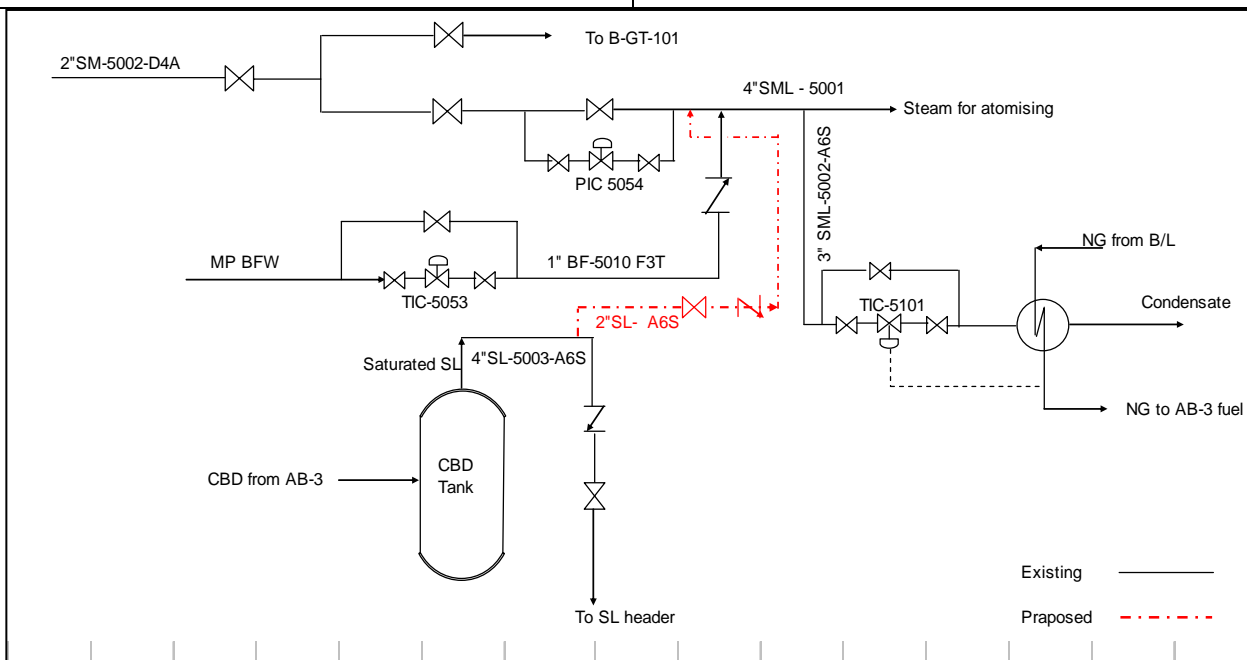

Agency that executed the project (With complete address and email) : In-house

Total investment, Rs. : 1.15 Lakhs

Year of completion : 2006-07

First year energy cost savings (anticipated),Rs.: 4.20 Lakhs

First year other savings, Rs.:

On annual basis	KWH 000'	Coal (Tons)	Gas Sm <sup>3</sup>	Oil (KL)	Other
Energy saved			50000		
Energy consumed after					
Energy tariff, Rs. / KWH/ Ton / Nm <sup>3</sup> /KL			Rs. 8.4 / Sm <sup>3</sup>		

Company complete address:

**Chambal Fertilisers and Chemicals Ltd.**  
P.O Gadepan - 325208, District KOTA, Rajasthan

Contact Person who could be contacted for more information:

**Mr. R. Chaba - Manager (Process)**  
Chambal Fertilisers and Chemicals Ltd.

We authorize Bureau to use this information for dissemination

Signature  
Date

### ENERGY CONSERVATION MEASURE Implemented in 2006-07

ID to be filled by BEE	Title of the measure			Sector	
Year to be filled by BEE				Technology	
Description of the energy conservation measure:  Energy saving by changing the range of Level control valve for surface condenser of CO2 compressor turbine in both the train of Urea-II plant					
Picture / Sketch / Drawing before modification			Picture / Sketch / Drawing after modification		
Agency that executed the project (With complete address and email) : In-house					
Total investment, Rs. : 0			Year of completion : 2006-07		
First year energy cost savings (anticipated),Rs.: 0.40 Lakhs					
First year other savings,Rs.:					
On annual basis	KWH 000'	Coal (Tons)	Gas Sm <sup>3</sup>	Oil (KL)	Other
Energy saved	20.6				
Energy consumed after					
Energy tariff, Rs. / KWH/ Ton / Nm <sup>3</sup> /KL	Rs. 2.1 / KWH				
Company complete address: <b>Chambal Fertilisers and Chemicals Ltd.</b> P.O Gadepan - 325208, District KOTA, Rajasthan				We authorize Bureau to use this information for dissemination	
Contact Person who could be contacted for more information: <b>Mr. R. Chaba - Manager (Process)</b> Chambal Fertilisers and Chemicals Ltd.					
				Signature	
				Date	

## ENERGY CONSERVATION MEASURE Implemented in 2006-07

ID to be filled by BEE	Title of the measure			Sector	
Year to be filled by BEE				Technology	
Description of the energy conservation measure:  Replacement of reflection filters with bag type filters at suction housing of air compressor in Ammonia-II to save pressure drop & running cost of reflection filter motor.					
Picture / Sketch / Drawing before modification			Picture / Sketch / Drawing after modification		
Agency that executed the project (With complete address and email) : In-house					
Total investment, Rs. : 0.24 Lakhs			Year of completion : 2006-07		
First year energy cost savings (anticipated),Rs.: 3.52 Lakhs					
First year other savings,Rs.:					
On annual basis	KWH 000'	Coal (Tons)	Gas Sm <sup>3</sup>	Oil (KL)	Other
Energy saved	44		31000		
Energy consumed after					
Energy tariff, Rs. / KWH/ Ton / Nm <sup>3</sup> /KL	Rs. 2.1 / KWH		Rs. 8.4 / Sm <sup>3</sup>		
Company complete address: Chambal Fertilisers and Chemicals Ltd. P.O Gadepan - 325208, District KOTA, Rajasthan				We authorize Bureau to use this information for dissemination  Signature Date	
Contact Person who could be contacted for more information: Mr. R. Chaba - Manager (Process) Chambal Fertilisers and Chemicals Ltd.					

## ENERGY CONSERVATION MEASURE Implemented in 2006-07

ID to be filled by BEE	Title of the measure		Sector		
Year to be filled by BEE			Technology		
Description of the energy conservation measure:  Re- configuration of LTS Guard & LTS reactor from series to parallel arrangement to save HP steam consumption in synthesis gas compressor turbine.					
Picture / Sketch / Drawing before modification			Picture / Sketch / Drawing after modification		
Agency that executed the project (With complete address and email ) : In-house					
Total investment, Rs. : 14.8 Lakhs			Year of completion : 2006-07		
First year energy cost savings (anticipated),Rs.: 13.7 Lakhs					
First year other savings,Rs.:					
On annual basis	KWH 000'	Coal (Tons)	Gas Sm <sup>3</sup>	Oil (KL)	Other
Energy saved			1630000		
Energy consumed after					
Energy tariff, Rs. / KWH/ Ton / Nm <sup>3</sup> /KL			Rs. 8.4 / Sm3		
Company complete address: <b>Chambal Fertilisers and Chemicals Ltd.</b> P.O Gadepan - 325208, District KOTA, Rajasthan				We authorize Bureau to use this information for dissemination	
Contact Person who could be contacted for more information: <b>Mr. R. Chaba - Manager (Process)</b> Chambal Fertilisers and Chemicals Ltd.				Signature Date	