

Energy Conservation Measure implemented in 2006-2007

ID to be filled by BEE	Title of the measure	Sector -PHARMACEUTICAL INDUSTRY			
Year to be filled by BEE	Using reaction calorimetry for Chemical Process	Technology			
Description of the energy conservation measure: <ol style="list-style-type: none"> 1. The heat of reaction from calorimeter gives the exact reason for the adiabatic temperature rise, whether due to <ol style="list-style-type: none"> i. Reaction ii. Reagent addition 2. Based on the heat release rate and the type, we can decide the process temperature and the utility temperature that is required 3. Minimum flow rate of the utility required for the process of interest could be calculated based on the rate of heat that is released/ absorbed by the process 4. Optimal Surface area for heat transfer controlled processes there-by selection of right reaction vessels. 					
Picture/ sketch/ drawing before modification (if available)			Picture/ sketch/ drawing after modification		
			<div style="border: 1px solid black; padding: 5px;"> <p style="margin: 0;">REACTION CALORIMETER---METTLER, RC1e</p>  </div>		
Agency that executed the project (with complete address and email):					
Total investment, Rs.: 2 Crores			Year of implementation: 2006 -2007		
First year energy cost savings, Rs.: 43.5 lakhs					
First year other savings, Rs.:					
On annual basis	KWh 000'	Coal (Tons)	Gas Nm ³	Oil (kL)	Other
Energy consumption before	976	0	0	0	0
Energy consumption after	836.52	0	0	0	0
Energy tariff, Rs/ kWh/ Ton/ Nm ³ / kL ...	139.42	0	0	0	0
Company complete address: Mr.S.Nammalvar (Vice president) 138-151, Sidco Industrial Estate, Alathur, Kanchipuram Dt. 603110. Ph-No : 044 27446320,27446205,27446206 Fax : 044 27446321 E.Mail :vsnam@orchidpharma.com				We authorise Bureau to use this information for dissemination Signature Date	
Contact person who could be contacted for more information:					

Energy Conservation Measure implemented in 2006-2007

ID to be filled by BEE	Title of the measure	Sector PHARMACEUTICAL INDUSTRY			
Year to be filled by BEE	Optimum utilisation of Energy in Water for injection system (WFI) and Air Handling Units (AHU)	Technology			
Description of the energy conservation measure:					
<p>Existing Practice: Steam was used to heat the dehumidified air in AHU and 0°C brine is used to cool the pure steam generated in WFI system</p> <p>Modified Practice: Water is being used to cool the pure steam generator and hot water which is coming out from the WFI is circulated to AHU heating coil</p>					
Picture/ sketch/ drawing before modification (if available)			Picture/ sketch/ drawing after modification		
Existing System			Modified System		
Agency that executed the project (with complete address and email):					
Total investment, Rs.: 7 Lakhs			Year of implementation: 2006 -2007		
First year energy cost savings, Rs.: 36.48Lakhs					
First year other savings, Rs.:					
On annual basis	kWh 000'	Coal (Tons)	Gas Nm ³	Oil (kL)	Other
Energy tariff, Rs/ kWh/ Ton/ Nm ³ / kL ...	2.55	0	0	222.84	0
Company complete address: Mr.S.Nammalvar (Vice president) 138-151, Sidco Industrial Estate, Alathur, Kanchipuram Dt. 603110. Ph-No : 044 27446320,27446205,27446206 Fax : 044 27446321 E.Mail :vsnam@orchidpharma.com Contact person who could be contacted for more information:				We authorise Bureau to use this information for dissemination Signature Date	

Energy Conservation Measure implemented in 2006-2007

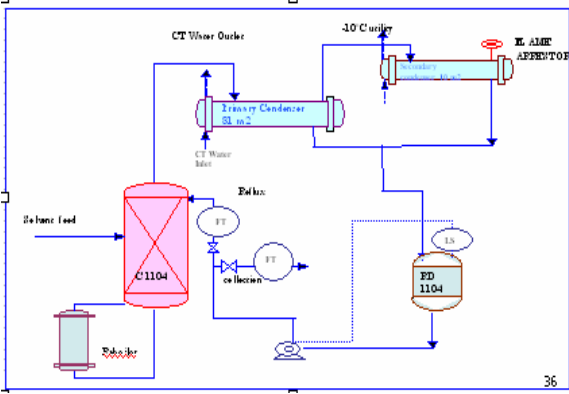
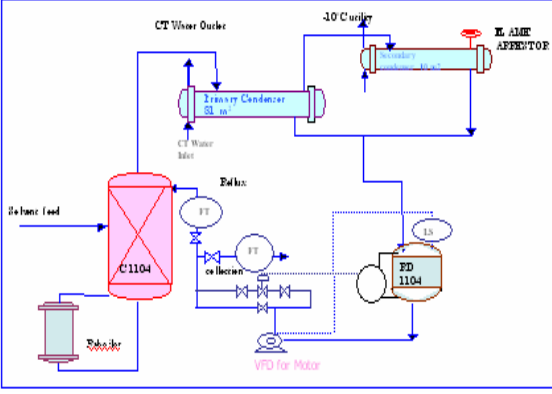
ID to be filled by BEE	Title of the measure Optimization of distillation column operation using Aspen Software (Simulation Technology)	Sector PHARMACEUTICAL INDUSTRY			
Year to be filled by BEE		Technology			
<p>Description of the energy conservation measure:</p> <p>Existing Practice: Reflux ratio was maintained 8 to separate Ethyl Acetate (EA) & Tetra Hydro Furan (THF) from EA+THF mixture</p> <p>Modified Practice: Reflux ratio was reduced to 5 from 8 to separate EA & THF from EA+THF mixture without affecting the quality</p> <ol style="list-style-type: none"> 1. The column operations can be optimized based on energy, impurities, etc. and various constraints like condenser & reboiler duty. 2. Detailed heat and mass balance can be calculated for all the unit operations like heater, cooler, condenser and reboiler load for distillation column. 3. For reducing energy various scenarios can be created using either sensitivity analysis e.g. changes of column pressure, reflux ratio, feed tray location, etc. 4. Using batch reactor model, we can calculate the optimum reaction time & temperature in a batch reactor 					
Picture/ sketch/ drawing before modification (if available)	Picture/ sketch/ drawing after modification				
					
Agency that executed the project (with complete address and email):					
Total investment, Rs.: 2 Lakhs	Year of implementation: 2006 -2007				
First year energy cost savings, Rs.: 15.51 Lakhs					
First year other savings, Rs.:					
On annual basis	kWh 000'	Coal (Tons)	Gas Nm ³	Oil (kL)	Other
Energy tariff, Rs/ kWh/ Ton/ Nm ³ / kL ...	509	0	0	103.5	0
Company complete address: Mr.S.Nammalvar (Vice president) 138-151, Sidco Industrial Estate, Alathur, Kanchipuram Dt. 603110. Ph-No : 044 27446320,27446205,27446206 Fax : 044 27446321 E.Mail :vsnam@orchidpharma.com				We authorise Bureau to use this information for dissemination	
				Signature	
				Date	

Energy Conservation Measure implemented in 2006-2007

ID to be filled by BEE	Title of the measure Desuperheater installed in -70 VGC	Sector : PHARMACEUTICAL INDUSTRY.			
Year to be filled by BEE	Technology				
Description of the energy conservation measure: Modification of refrigeration system with installation of efficient desuperheater to reduced inlet pressure refrigerant to condenser					
Picture/ sketch/ drawing before modification (if available)	Picture/ sketch/ drawing after modification				
Agency that executed the project (with complete address and email):					
Total investment, Rs.: 10 Lakhs	Year of implementation: 2006 -2007				
First year energy cost savings, Rs.: 0.91Lakhs					
First year other savings, Rs.:					
On annual basis	kWh 000'	Coal (Tons)	Gas Nm ³	Oil (kL)	Other
Energy consumption before	158.5	0	0	0	0
Energy consumption after	158.3	0	0	0	0
Energy tariff, Rs/ kWh/ Ton/ Nm ³ / kL ...	0.2	0	0	0	0
Company complete address: Mr.S.Nammalvar (Vice president) 138-151, Sidco Industrial Estate, Alathur, Kanchipuram Dt. 603110. Ph-No : 044 27446320,27446205,27446206 Fax : 044 27446321 E.Mail :vsnam@orchidpharma.com				We authorise Bureau to use this information for dissemination Signature Date	

Energy Conservation Measure implemented in 2006-2007

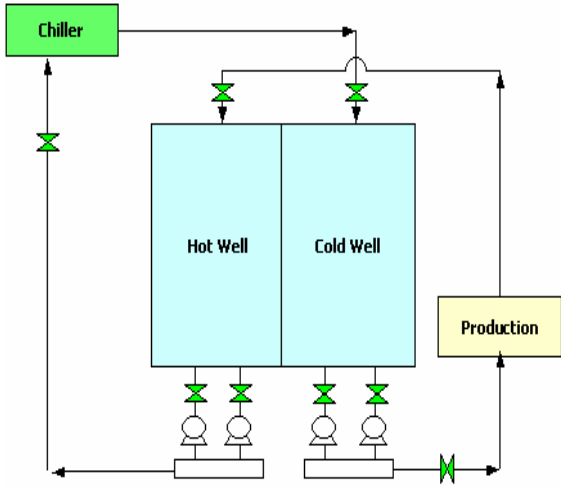
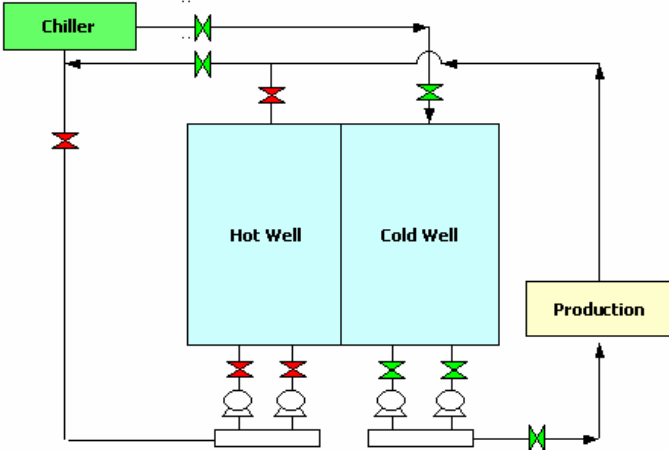
to be filled by BEE	Title of the measure Elimination of primary pumps operation in refrigeration system	Sector : PHARMACEUTICAL INDUSTRY.			
Year to be filled by BEE		Technology			
Description of the energy conservation measure:					
Reduces a power consumption in pump circuit by eliminating primary pump. This process is carried out with efficient monitoring method					
Picture/ sketch/ drawing before modification (if available)	Picture/ sketch/ drawing after modification				
					
Agency that executed the project (with complete address and email):					
Total investment, Rs.: 4 Lakhs	Year of implementation: 2006 -2007				
First year energy cost savings, Rs.: 14.3 Lakhs					
First year other savings, Rs.:					
On annual basis	kWh 000'	Coal (Tons)	Gas Nm ³	Oil (kL)	Other
Energy consumption before	278.23	0	0	0	0
Energy consumption after	275	0	0	0	0
Energy tariff, Rs/ kWh/ Ton/ Nm ³ / kL ...	3.23	0	0	0	0
Company complete address: Mr.S.Nammalvar (Vice president) 138-151, Sidco Industrial Estate, Alathur, Kanchipuram Dt. 603110. Ph-No : 044 27446320,27446205,27446206 Fax : 044 27446321 E.Mail :vsnam@orchidpharma.com			We authorise Bureau to use this information for dissemination Signature Date		

Energy Conservation Measure implemented in 2006-2007

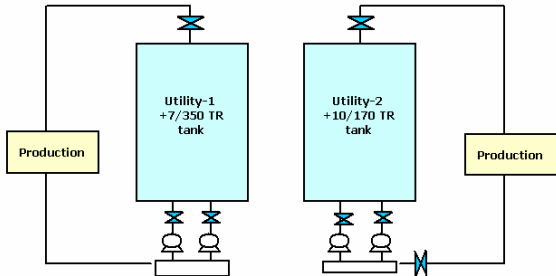
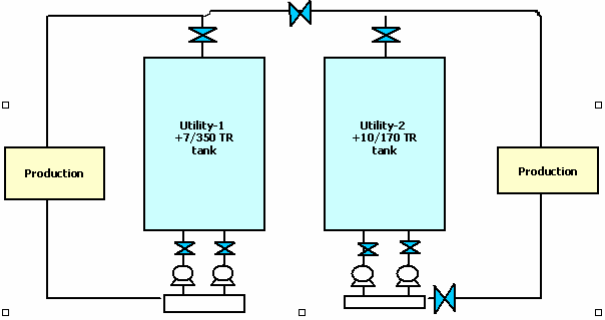
to be filled by BEE	Title of the measure	Sector : PHARMACEUTICAL INDUSTRY.			
Year to be filled by BEE	Interconnection of utility – 1 & 2 +7 system	Technology			
Description of the energy conservation measure: <p style="text-align: center;">Interconnection of +7 and +10 system from utility – 1 & 2 to increase service efficiency to production department, reduce power, provide supply of brine solution as per requirement</p>					
Picture/ sketch/ drawing before modification (if available)		Picture/ sketch/ drawing after modification			
Before Modification 		After Modification 			
Agency that executed the project (with complete address and email):					
Total investment, Rs.: 32 Lakhs		Year of implementation: 2006 -2007			
First year energy cost savings, Rs.: 38.89 Lakhs					
First year other savings, Rs.:					
On annual basis	kWh 000'	Coal (Tons)	Gas Nm ³	Oil (kL)	Other
Energy consumption before	286.76	0	0	0	0
Energy consumption after	278	0	0	0	0
Energy tariff, Rs/ kWh/ Ton/ Nm ³ / kL ...	8.76	0	0	0	0
Company complete address: Mr.S.Nammalvar (Vice president) 138-151, Sidco Industrial Estate, Alathur, Kanchipuram Dt. 603110. Ph-No : 044 27446320,27446205,27446206 Fax : 044 27446321 E.Mail :vsnam@orchidpharma.com :			We authorise Bureau to use this information for dissemination Signature Date		

Energy Conservation Measure implemented in 2006-2007

to be filled by BEE	Title of the measure	Sector: PHARMACEUTICAL INDUSTRY.			
Year to be filled by BEE	Phase-25 plant +7 Chilled water 30TR load shifted from MPSR air-cooled chiller to +7 water-cooled chiller in Utility-1.	Technology			
Description of the energy conservation measure:					
Installation of efficient 350 T.R centrifugal compressor instead inefficient system					
Picture/ sketch/ drawing before modification (if available)			Picture/ sketch/ drawing after modification		
Vapour Absorption system					
Agency that executed the project (with complete address and email):					
Total investment, Rs.: 0.2 Lakhs			Year of implementation: 2006 -2007		
First year energy cost savings, Rs.: 6.48 Lakhs					
First year other savings, Rs.:					
On annual basis	kWh 000'	Coal (Tons)	Gas Nm ³	Oil (kL)	Other
Energy consumption before					
Energy consumption after					
Energy tariff, Rs/ kWh/ Ton/ Nm ³ / kL ...	1.46	0	0	0	0
Company complete address: Mr.S.Nammalvar (Vice president) 138-151, Sidco Industrial Estate, Alathur, Kanchipuram Dt. 603110. Ph-No : 044 27446320,27446205,27446206 Fax : 044 27446321 E.Mail :vsnam@orchidpharma.com				We authorise Bureau to use this information for dissemination	
				Signature	
				Date	