



The Arvind Mills Ltd. Santej.

Company Profile : -

Arvind Mills has set the pace for changing global customer demands for textile.

Fore vision and technology has brought arvind to be one of the top three producers of Denim in the world. Arvind is already making its presence felt in shirtings,Knits and Khakis fabric apart from being all set to create ripples in the ready to wear Garments world over.

Lalbhai Group:-

Textiles / Yarns / Garments.
The Arvind mills Ltd.
The Arvind Products Ltd.
Arvind Brands Ltd.

Our Santej Unit is manufacturing best quality Shirting,Bottom wt and Knit Garments.In Year 2004-2005 Company has recorded annual turnover of Rs.700 Crore; With total production of 52.18 million meter

ENERGY MANAGEMENT POLICY: -

The Arvind Mills will be committed to responsible energy management and will practice energy efficiency throughout all of its units.

1. Policy :

The Arvind Mills Limited is committed to conserve Energy and reduce the Specific Energy Consumption in it's Production line. This is to be attained by

- Complying with the Energy Legislation & other regulation.
- Creating awareness among employees & encouraging their innovative ideas for Energy conservation.
- Communicate Energy Management Policy to all employees & encourage their involvement through training & Participation.
- Minimising waste generation & promoting -reuse & recycling and as last resort disposal of waste in an environment friendly manner.
- Use of Energy efficient alternatives, ecofriendly technology & promoting use of non-conventional source of energy.
- Adopt Effective Energy Management System.
- Identifying Energy saving opportunities through systematic & Scientific approach
- Adopt diligent & effective maintenance and work practices to ensure quality and efficient operation of the equipments and there by saving the energy

This Energy Management Policy intends to conserve the Natural Resources for our Future Generation

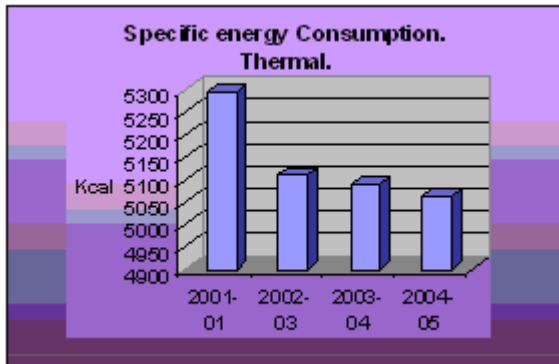
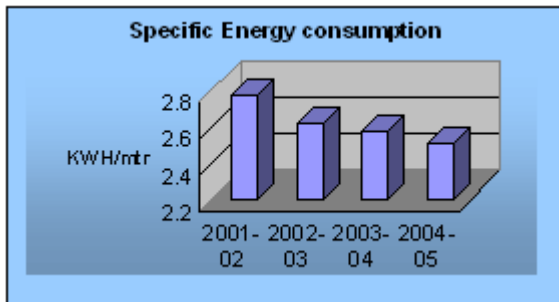

Graphical Representation of specific energy consumption: -

Energy Conservation Cell :

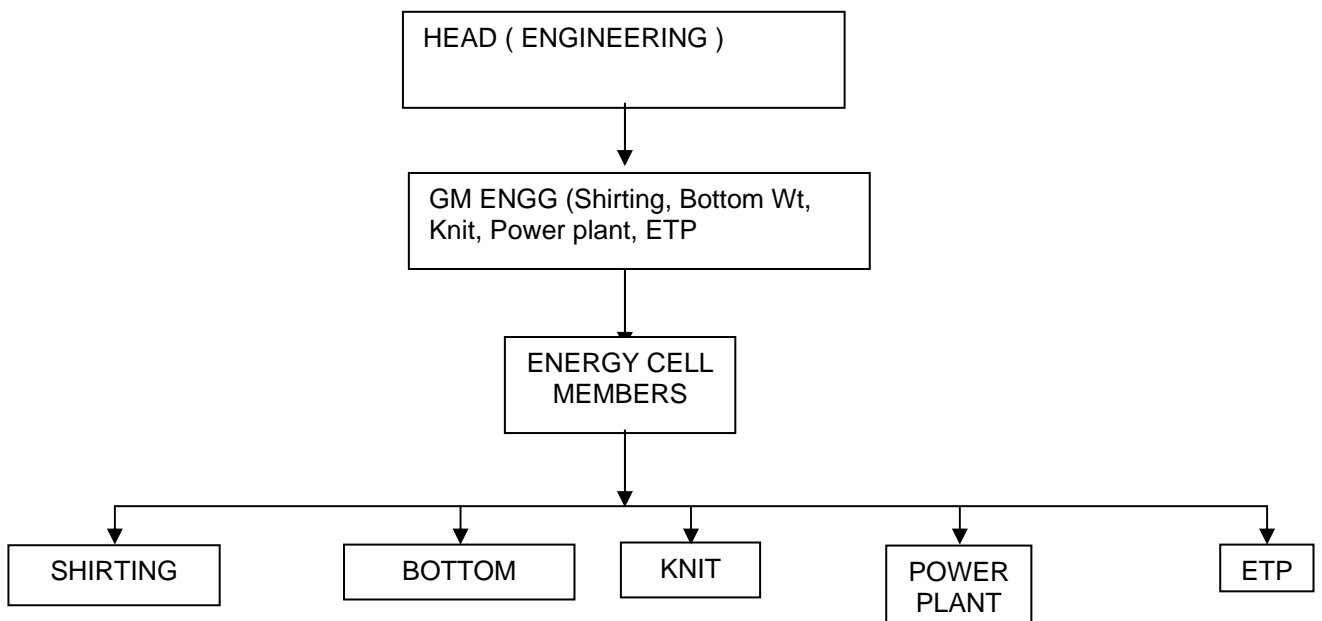

Monitoring and Reporting Systems

1 The unit is committed to monitor continuously the saving achieve and reduce specific energy by 1% ever year. We have also formulated clear-cut policy for energy conservation

- a. Formation of energy conservation cell
- b. Day to day monitoring of energy consumption and give feed back to user end
- c. Calculation of energy consumption on monthly basis

- e. Selection of best equipment and technology
- f. Involvement of workers and award scheme for best performance in energy saving scheme.

Salient Features of Energy Conservation Cell :

- Ensure that energy management operations are supportive of the goals.
- Maintain liaison with the Maintenance/ production department.
- Recommend sound policies directed towards energy conservation.
- Develop long range plan for implementing innovations
- Utilize consultants when necessary to identify energy conservation measures.
- Assist maintenance managers in evaluating HVAC and energy equipment maintenance staff to ensure effectiveness.
- Employ effective interpersonal skills.
- Review and negotiate energy purchase agreements and make recommendations regarding energy fuel selection.
- Provide regular reports as to the overall effectiveness of the energy management program.

Some Unique Energy conservation Projects :

1.Agro-waste fuel boiler.



We are having CPP & boilers to meet the requirement of power & steam of AML campus (Santej). The steam generated from HRSG (waste heat recovery boilers) of gas turbines is not sufficient to meet the demand of production departments. to meet total steam demand, we are having another boiler where costly fuel like FO was used. we installed the agrowaste fuel (FBC) boiler in year 2002, to reduce the cost of steam production. Considering the generation 312 tons per day and overall 345 days of operation the annual thermal energy saving achieved to 65.8million Rs.

Considering total investment of Rs. 20 million pay back period is 3.2 months.

2 EFFLUENT TREATMENT PLANT PROJECT :-

PROJECT -2(A)

In the RO pretreatment section, in order to remove the Silica content as well as colloidal particulate from the treated waste water , AIC Watson designed one Turbo Circulator unit. Initially Thermax was Operating the plant. They were dosing dolomite to remove the silica.



Later on we realized that treated wastewater silica levels are within the acceptable range to RO membranes. Then the treatment chemicals were changed to lime, ferric Chloride & polymer. Treatment with these chemicals resulted in tremendous sludge generation & difficulty of lime handling. Further, any excess Ferric Chloride dosing is problematic to membranes.

We replaced even these chemicals with specialty chemicals, thereby we are getting much better water quality. Sludge generation minimized by almost 1000 tons/ annum. Since the dosage of these chemicals is low, handling became simple. This change in treatment strategy resulted in annual savings of Rs 50 lakhs. This is a unique treatment considering the fact that it results in lower operating cost, lower hazardous sludge generation as well as easy handling.

PROJECT 2(B)

Spent acid usage for neutralization of effluents.

Most of the textile mills effluent streams viz.: Dyeing effluents, Mercerizing effluents are alkaline in nature. For effective chemical treatment subsequent biological treatment more or less neutral pH is required. This necessitates addition of acids either HCl or Sulfuric acid to the effluents . We were using HCL for this. With the availability of spent acid from dye/ pigment manufacturers (which is waste for the dye / pigment manufacturers) we switched over to spent Sulfuric acid of about 24%. Across the group the net saving of 10million Rs achieved.

PROJECT 2(C).

Usage of spent Al. Chloride in place of poly aluminum chloride.

In our group's effluent treatment plants, in the chemical treatment section, we were using Poly aluminum chloride for coagulation purpose. Initially we were using Virgin PAC from Grasim Industries which is quite expensive. Later on we switched over to by product aluminium chloride solutions thereby Saving about 1 crore / annum.

PROJECT3



200Nos. Solar Street Light have been installed in plant areas and in remote areas

Annual Electrical Saving :-1.09 lakhs kWh

Annual Saving in Rs :- 5.47 lakhs

Investment made :- 94 lakhs.

Energy conservation Plans and Targets: -

We are going to install PLC based control system for compressed air and 2nos FRP Fans.