

A portrait of Swami Vivekananda, a prominent Hindu monk and philosopher. He is depicted from the chest up, wearing a traditional orange turban and a dark red, long-sleeved kurta. His arms are crossed over his chest, and he has a serious, contemplative expression. The background is a soft, light-colored gradient.

***This world is neither good nor evil;
Each man manufactures a world for himself...***

- Swami Vivekanand

The background of the slide is a scenic landscape photograph. It features a large, snow-capped mountain peak in the distance, surrounded by a dense forest of evergreen trees. In the foreground, there is a calm body of water that perfectly reflects the mountain and the surrounding greenery. The sky is a clear, bright blue. The overall scene is peaceful and natural.

Energy Conservation at UPL

– Case study of
efforts

Sunil Motiramani
& EC Team UPL

ENERGY MANAGEMENT POLICY

We, at United Phosphorus Limited are committed to improve energy efficiency continuously by establishing and implementing effective energy management programs worldwide that support all operations and customer satisfaction while providing a safe and sustainable environment.

To meet above goals we will strive

- To be amongst the lowest specific energy consumer in the industry we operate.
- To maximize the use of renewable fuels and low energy level fuels in our operations.
- Maximization of self generation
- Manage efficiently the utilization of energy resources, upgrade equipments and employ cleaner and more efficient technology.
- Train employees to make UPL the pace setter in the area of energy conservation.
- Carry our Internal & External Audits to identify areas for improvement.
- Enrich our experience on energy conservation by exchange of ideas with other organization.
- Promote awareness among all members of UPL.
- As part of energy conservation we are committed to reduce our energy consumptions by 10% from the present level by 2010.

Company Profile

United Phosphorus Limited (UPL) is a global generic crop protection, chemicals and seeds company, headquartered in India (Mumbai). UPL and Advanta, the two companies in our group, are listed on the Indian stock exchange, with a combined market capitalization of approx \$2.5 billion. The revenue of our Company has grown at a CAGR of 26% over the last 5 years. Our fantastic growth is the result of successful backward and forward integration by taking advantage of the consolidation opportunities within the agrochemical industry. Integrating the acquired companies is as challenging as acquiring them and at UPL, we have a dedicated in-house team specializing in this task.

Energy Consumption of UPL Units (at Gujarat)

UPL is having 6 no's of production units including one Captive Power Plant comprising of one GTG of rating 41 MW and one STG of rating 21 MW in Gujarat State. UPL is producing different types of products and the major products are DVACL, MPBAD, Ammonia, Antracol, Monocrotophos (MCP), IKI220, Acephate, Caustic Chlorine (CCP), Mencozeb (MNZ), etc. UPL uses 3 types of energy sources i.e. Electricity, Natural Gas and Furnace oil. Out of these 3, Natural Gas has the highest share (almost 87 % of total energy bill). Total cost of energy bill for last year was Rs. 159.75 Crores, which includes Rs. 136.38 crores for Natural Gas, Rs. 16.34 crores for Electricity, Rs. 2.85 crores for Furnace oil and Rs. 4.24 crores for water. Last year company consumed 895 Lac SM3 of Natural Gas, 26 Lac Liters of Furnace oil, 184.84 Lac KL of water and 2456 Lac kWh of Electricity. Due to sincere efforts in the direction of Energy Conservation by the company there has been significant reduction in the consumption of energy.

Combustion Efficiency improvement with closed loop O2 control through VFD.



Replaced old inefficient burners with new weishput burner having oxygen trim up to 1.3- 2.2 % O₂, with closed loop control for 4 no's of 10T & 3 no's of 5T boilers which improved the boilers efficiency. After this implementation specific consumption of natural gas is reduced from 84 to 78 SM³ per Ton of steam generation. Savings achieved by this implementation is as follows:

Total savings : Rs. 233 Lacs / annum

Investment : Rs. 150.0 Lacs

Payback period : 8 months

Steam trap correction program across UPL

Thermography study

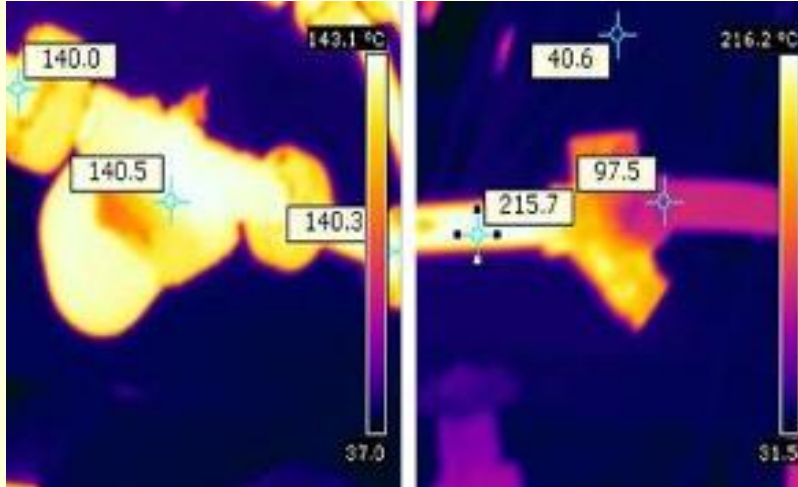

Not Working

Working



Wrongly Installed

Corrected

Totally 851 no's of stem traps (TD3 – 618, Float – 219, Inverted Bucket – 14) installed and 771 traps were audited / studied by Thermography. Replaced not working & not suitable traps with recommended type & size of traps for distribution lines and for process equipments. After implementation specific steam consumption for process reduces drastically and batch time reduces, hence production yield increased. Savings achieved by the above implementations are as follows:

Savings achieved : Intangible

Investment : Rs. 10.0 Lacs

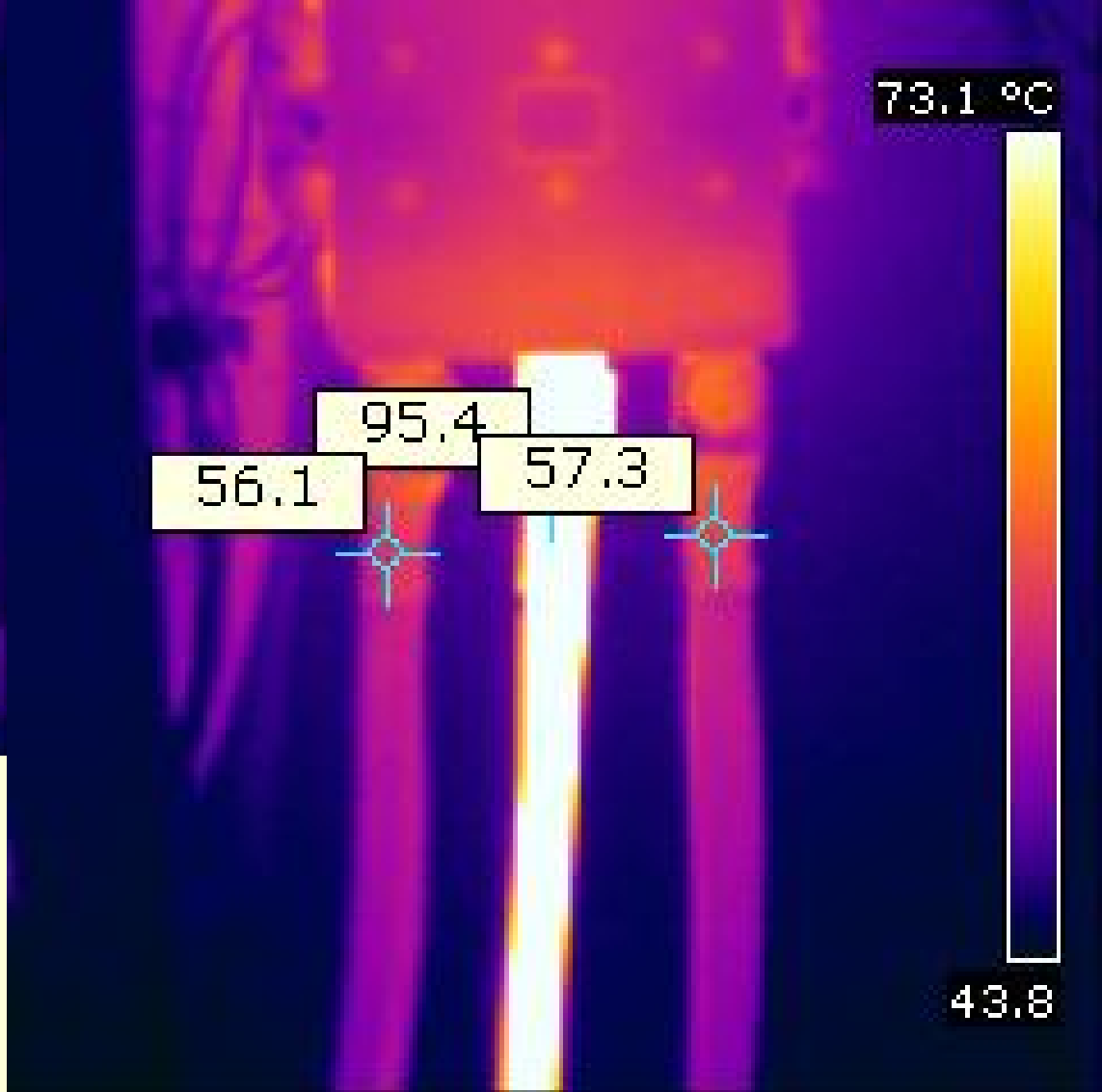

Steam trap and insulation survey
Can be done without touching
the component

Electrical survey shows middle contactor heated
Up and may fail if not corrected the lug loose
Connection in time –This prevents major loss
Of production.

Thermography Study

Fouling of Inter cooler detection



1000cfm Air Compressor Intercooler tube leakage
detection and correction

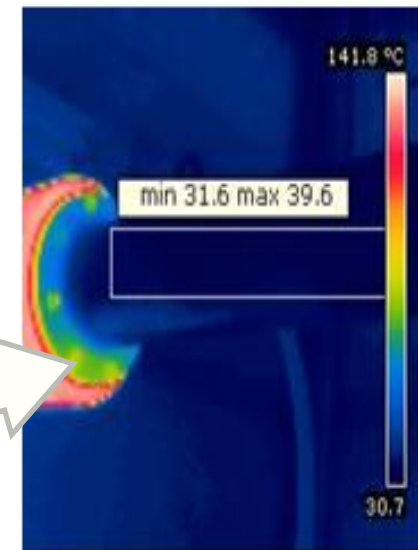
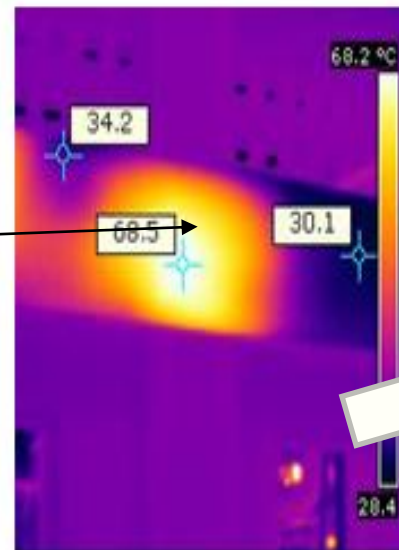

Optimization of Air compressor by Inter-connection and capacity control



Three air compressors of different capacities operating in parallel to maintain plant requirement. By interconnecting the 3 compressors, the plant requirement was full filled and unloading time was reduced by reducing pulley to match get loading up to 80% in one 1000 cfm compressor.

Compressor operation before and after maintenance

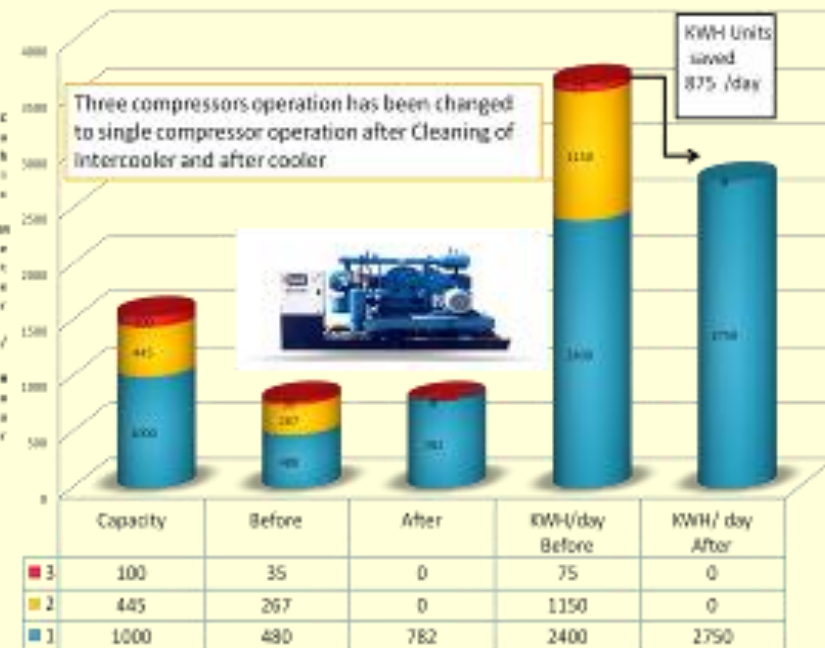

Now only one 1000 cfm compressor caters full plant requirement with savings Energy.

Savings achieved : Rs. 18 Lacs / annum

Investment : Rs. 1 Lacs

Payback period : < 1 month

Energy Efficient Motors

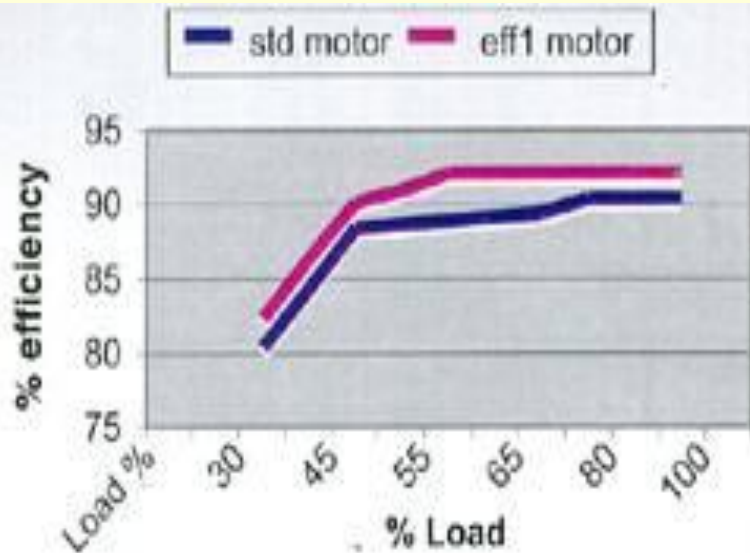

Replaced old and inefficient motors with Energy efficient (Eff-1) motors. Energy efficient motors having more efficiency comparing to standard motors at all the load conditions.

Total no of motor replaced : 31 no's

Estimated savings : Rs. 4.0 Lacs / annum

Investment : Rs. 8.0 Lacs

Payback period : 24 months

Insulation

Insulation leakage study with Thermography

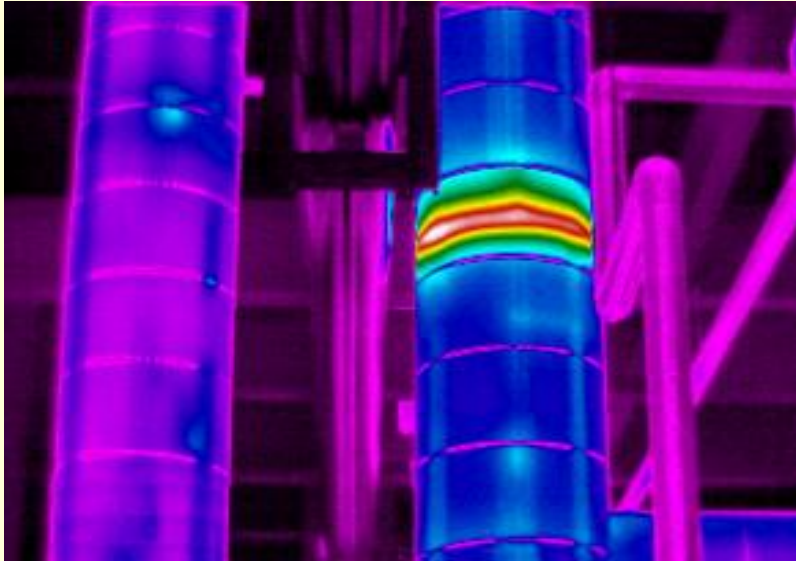

Provided new insulation for header lines and reactors for chilled water and brine. Regularly monitoring the insulation condition of chilled water and brine distribution lines by Thermography to avoid leakages and hence avoiding heat loss from the insulation.

Savings achieved : Rs. 47.8 Lacs / annum

Investment : Rs. 13.0 Lacs

Payback period : 3 months

Use of C-FRP Pipe line with less frictional losses and optimization of pumping

Before Implementation



After Implementation



Replaced MS 12" Header pipe line from cooling tower to Ammonia plant by CFRP (Cerolene Fiberglass Reinforced Plastic) 14" line. The pressure drop reduction has resulted in flow increase from 720 M³/Hr to 900 M³/Hr and pressure drop reduced from 2.1 to 1.2 Kg/cm² in the pipe line. The Pump operating point shifted very near to Best Efficiency point (84%) with power savings.

These Non metallic lines have advantages, viz, reduced cost of recurring painting, corrosion and very low friction, as internal surface is mirror finish.

Savings achieved : Rs. 18.8 Lacs / annum

Investment : Rs. 10.0 Lacs

Payback period : 7 months

Replaced old Reciprocating Air compressor with screw compressor with VFD

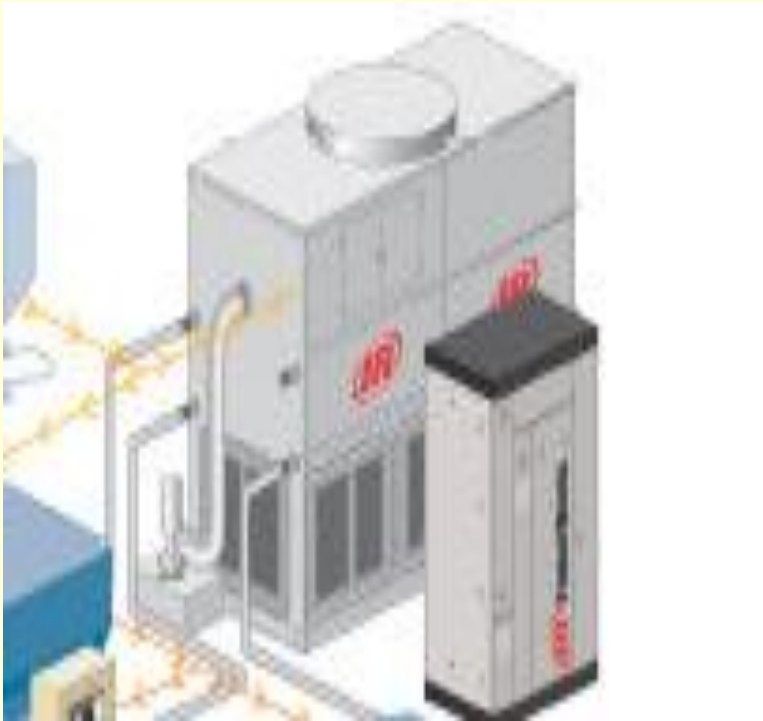

Installed one integrated variable speed rotary compressor. This will make the system more reliable and easy to operate. There would be reduction a huge reduction in operating and maintenance cost. Apart from this compressor is operated without pressure band. It would have a automatic capacity control to match the demand.

Estimated savings : Rs. 12.5 Lacs

Investment : Rs. 17 Lacs

Payback Period : 16 months

Performance improvement in pumps

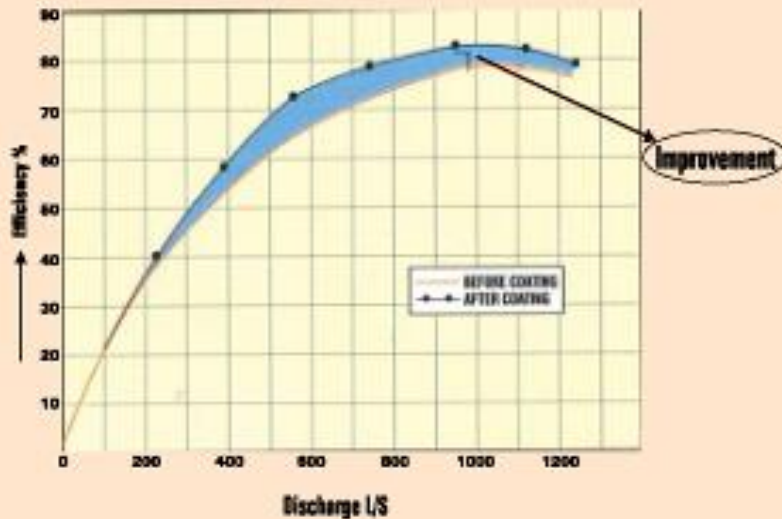

Improved pumps efficiency to above designed best efficiency point by providing corracoat-coating to pump impeller and casing. After this coating flow has increased because of smooth surface area and reduces friction losses and reduces power consumption. Thus efficiency of pump increased to 7% more then the designed efficiency.

Details	Before	After
Flow (M ³ /Hr)	450	460
Head (Mtrs)	23	22
Power (KW)	40.3	35.9
Overall Efficiency (%)	70	77
S.E.C (KW / M³)	0.0895	0.0780
Saving in S.E.C	0.0115	
Power savings (KW/ hr)	5.29	
Annual monitory savings (Rs .Lacs)	2.1	
Investment (Rs. Lacs)	0.40	
Payback period (Months)	3 months	

EPANET Study – CCP Plant

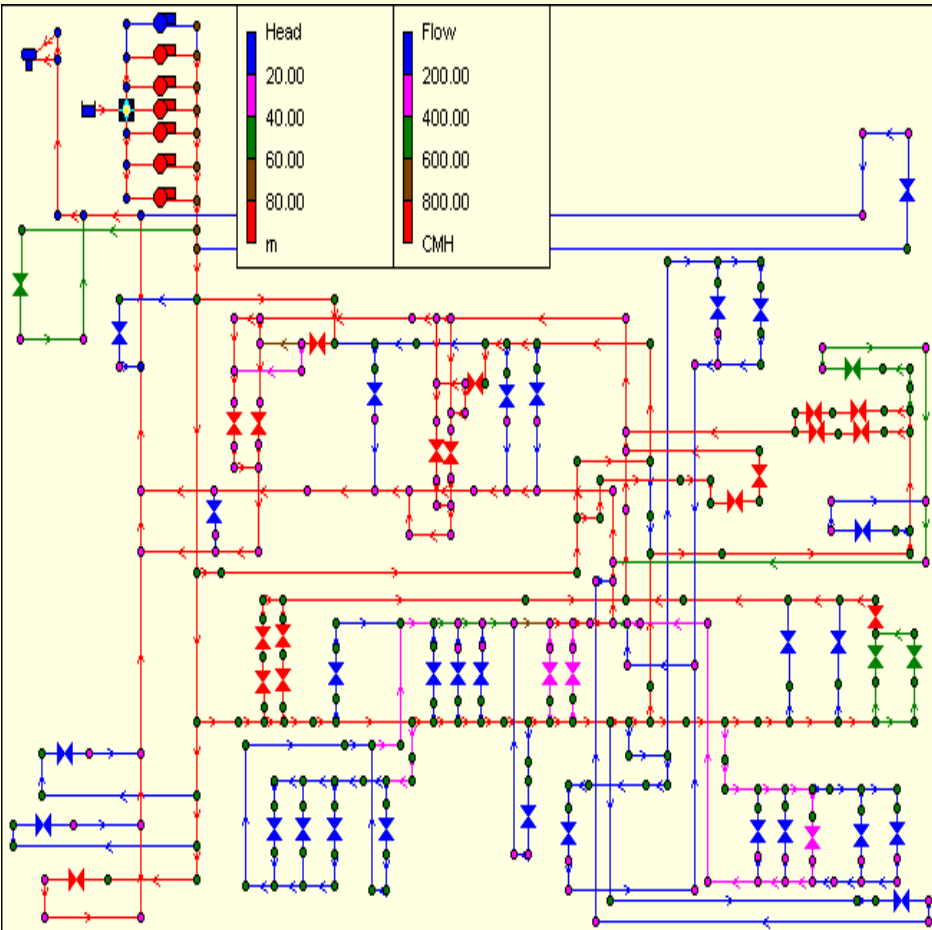

This internal study revealed the bottlenecks of critical Heat Exchangers where the process rates were restricted. After above study depending upon the Head load flows were controlled and optimized pumping power, This lead to reduction in SPC from 0.15 Kw/M3/hr, to 0.11. By optimization of pumping, to 1X 850m³/hr and 1X350 M³/hr against 2X850m³/hr pumps.

Savings:

Power savings : 67 Kw (210 -143)

Monitory savings : Rs. 26 Lacs / Annum

Investment : Negligible

Installation of Evaporative Condenser



Replacement of condenser and CT with Evaporative condenser unit lead us the reduction in SPC. The benefit is on the account of lower cooling water circulation power and lowered condensing temperature compared to CT and condenser unit. Also cost of condenser cleaning and effect of fouling is minimized. Online cleaning is possible here in as water is circulating on the tubes containing Refrigerant.

Savings:

SPC of Before : 1.13 KW/TR

SPC After : 0.87 KW/TR

(only compressor power is considered here)

Power savings : 300643 KWH/Annum

Monitory savings : Rs. 18.03 Lacs / annum

Investment : Rs. 11.00 Lacs

Payback period : 8 Months

Use of Wind power for Eco Ventilation

- 182 Nos EcoVentilators at U-3 replacing 67 KW continuous load
- Annual saving 34 Lacs in power.
- Investment aprox 10 Lacs.
- All our Godown are on Eco-Ventilators

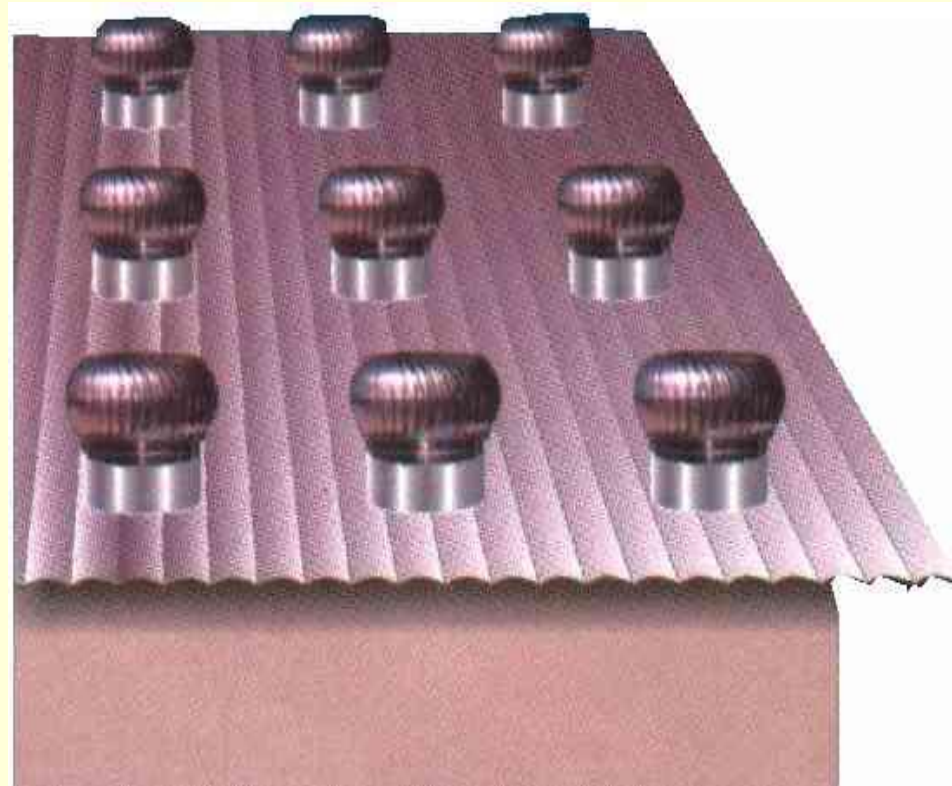

Completed EC projects

- Process Heat recovery thru' Recuperator.
- Condensate water recovery
- Booster pump at Caustic Evaporator Unit.
- VFDs for H₂ , Cl₂ and Air Compressor and H₂ Blowers.
- Bio-gas plant
- Solar Water Heater
- Silver plating to reduce the mV drop and temperatures in Bus bars and Cell connectors.

Effect on Temp. and mV Drop

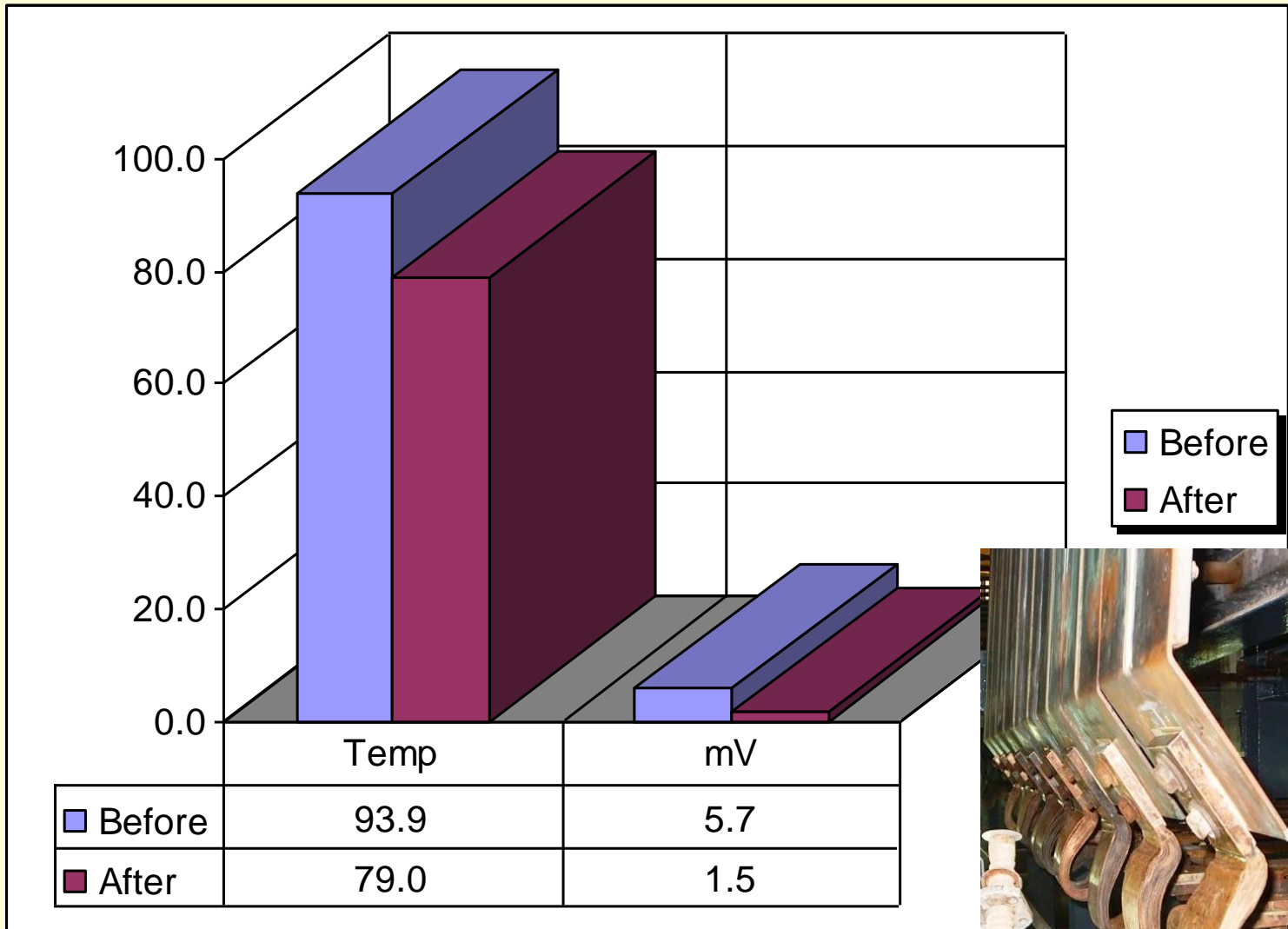

Upcoming EC measure

Equipment	Investment (Rs. Lacs)	Savings (Rs. Lacs)
De-Super heater installation for LP steam.	3.5	28.0
<p>Thermo-compressor (Utilization of Vent LP steam)</p> <p>The System: The T/C system will have “suction steam”, available from LP mains which is at 2.2 ata, “Motive steam”, from the 41 ata. steam line and “discharge steam”, which will be delivered into the 5.5 ata. steam mains. We observed that at the moment about 8.5 tph LP steam is generated. Out of this 6 tph is utilized by the VAC. The balance (2 to 2.5 tph) is condensed in the STG condenser.</p>	11.0	240.0

New Ideas under trial

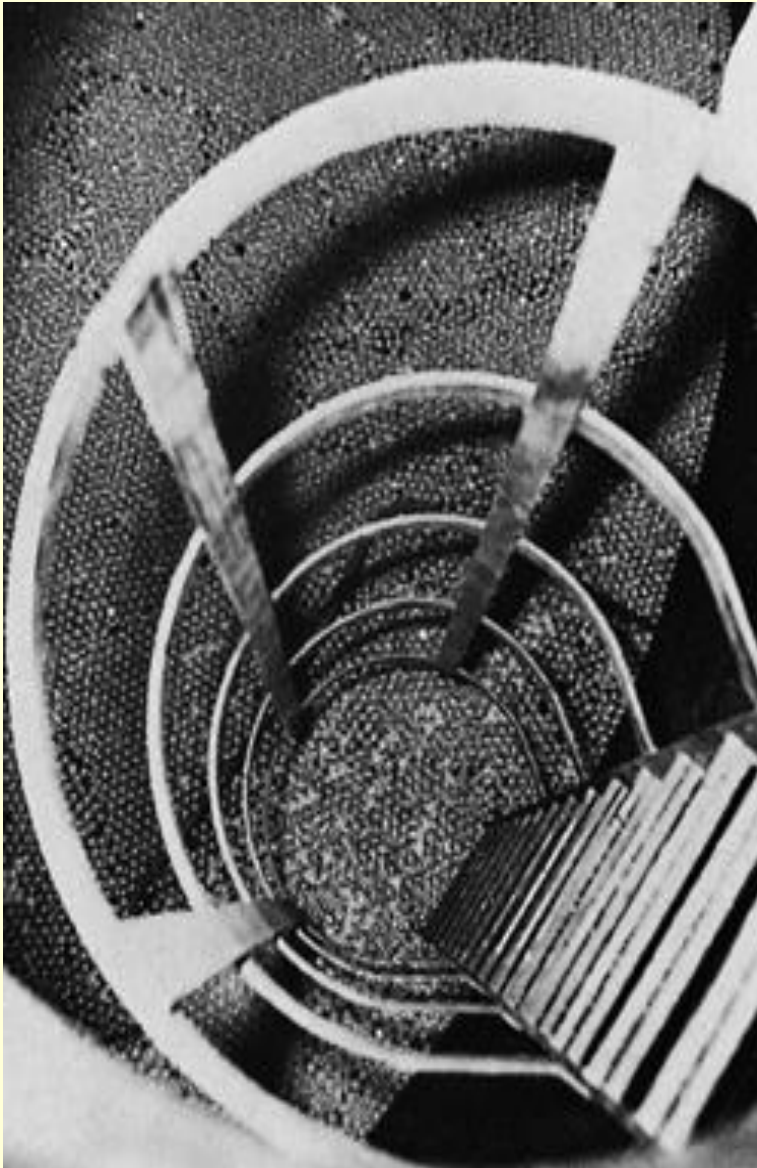

- Evaporation and Heat loss reduction by float balls
- plates With Electro-static

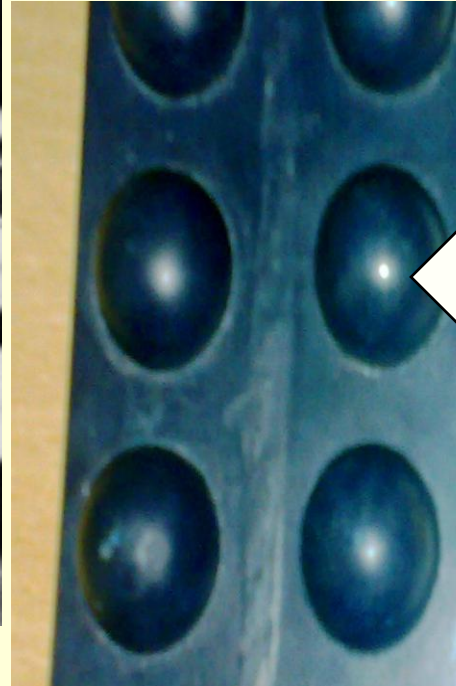

Better Idea

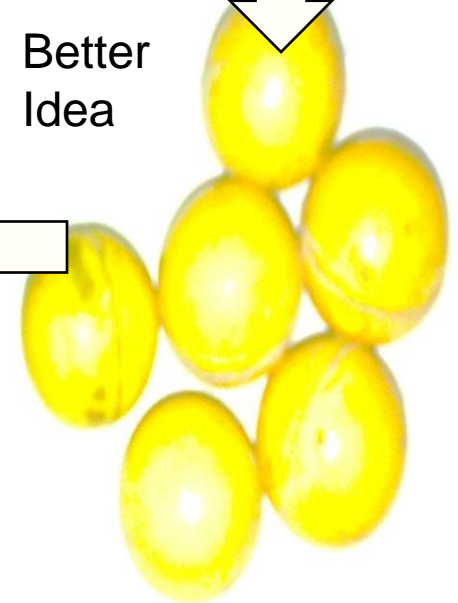

Magnetic saver installations



Performance monitoring of Spiral HE With & Without Magnetic Saver

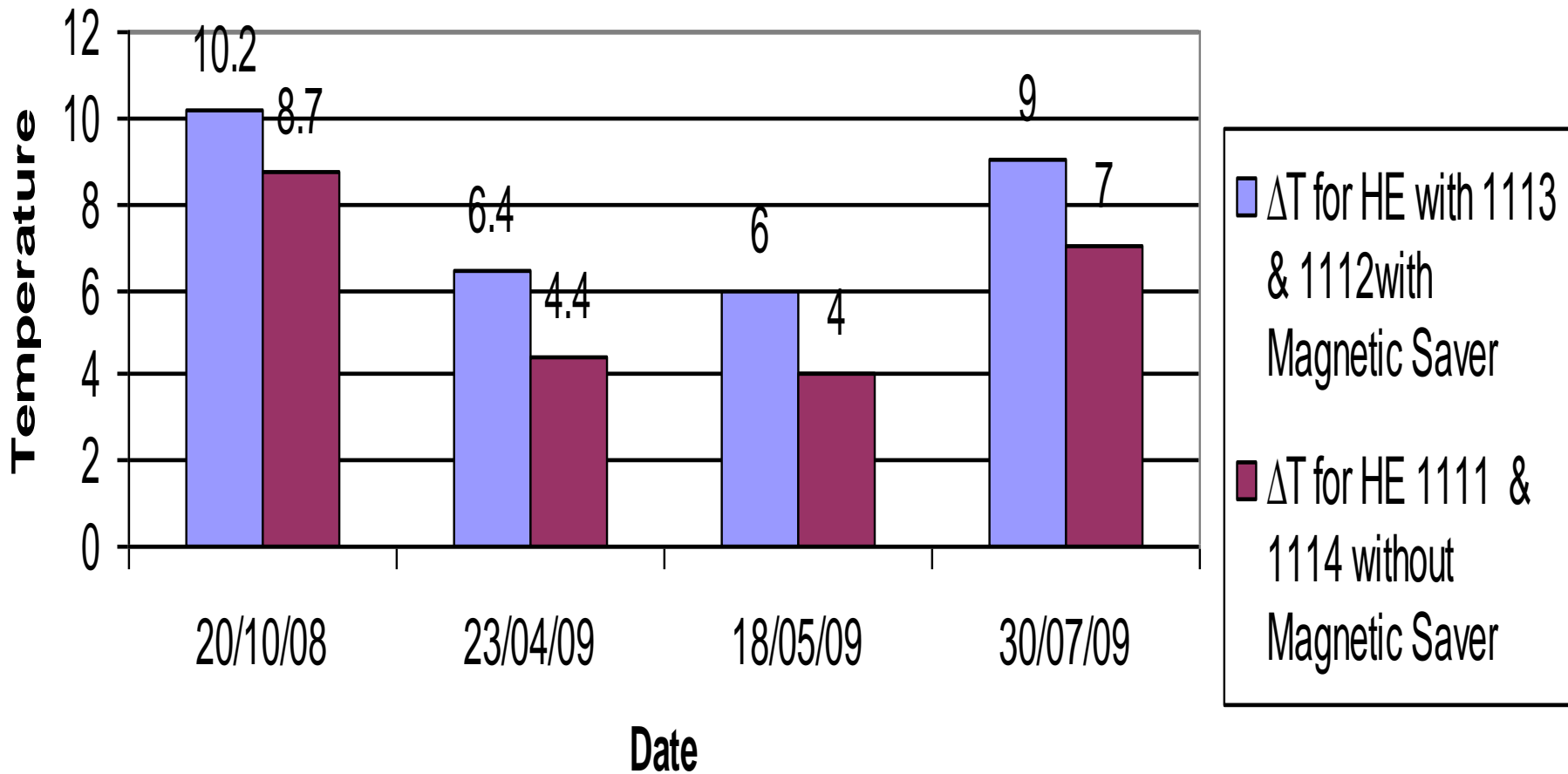

Just imagine what affect you and I can cause
if we all take up these simple steps.



Lets save our planet..

If all of us contribute,
we can multiply the affect many times over.



I'm doing my bit. I'm sure you'll join me.
Thanks for your time.