

## **Bureau of Energy Efficiency (BEE )**

**Two Day Technical Workshop on Adoption of Energy efficient  
process technologies & practices and implementation of  
Energy Conservation Act 2001 in  
Power Sector**

**13<sup>th</sup> & 14<sup>th</sup> May 2010**

**Energy Saving in Compressed Air with Efficient  
Capacity Control and  
Supply & Demand Side Management**



# **What does your Compressed Air Cost???**

# Energy Cost

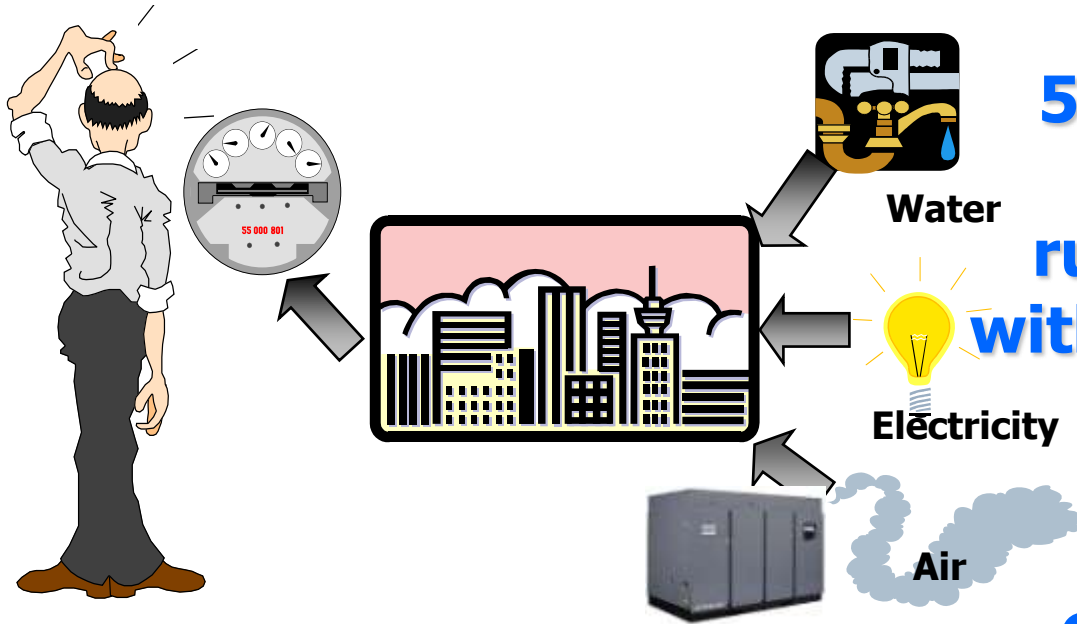

**500 SCFM Compressor i.e.  
120HP / 90kW Motor  
running 24 hrs X 365 days  
with 70% Load consumes  $\approx$   
6,00,000 kWh annually  
at rate of Rs. 4/kWh,  
Costs Rs. 24,00,000/year**

***Which is 4 times the cost of Compressor itself !!***

# Compressed Air Energy

- Inefficient power source even if well maintained

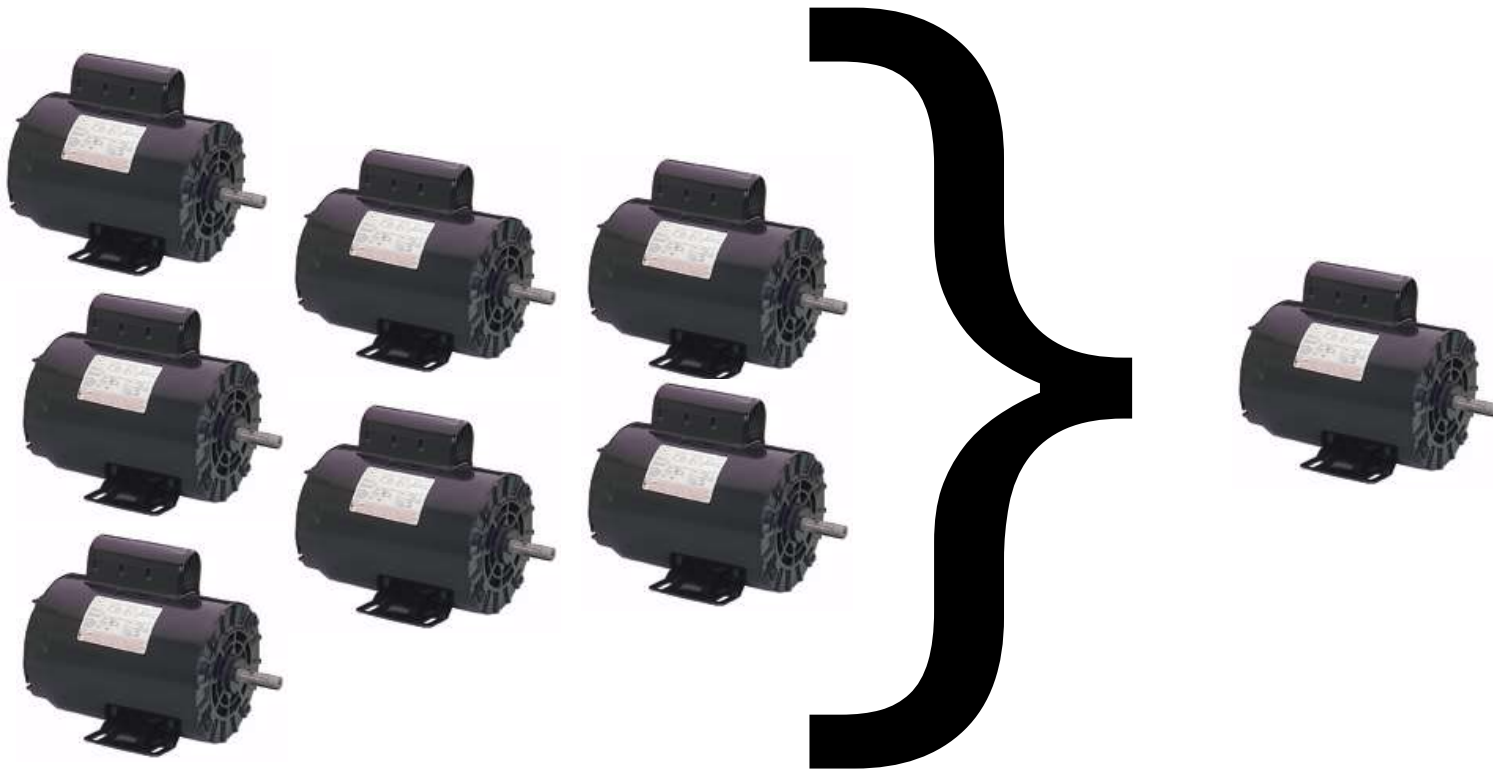

**SEVEN** compressor horsepower

yields . . .

**ONE** horsepower of compressed air

# Compressed Air Utilisation In A Conventional System

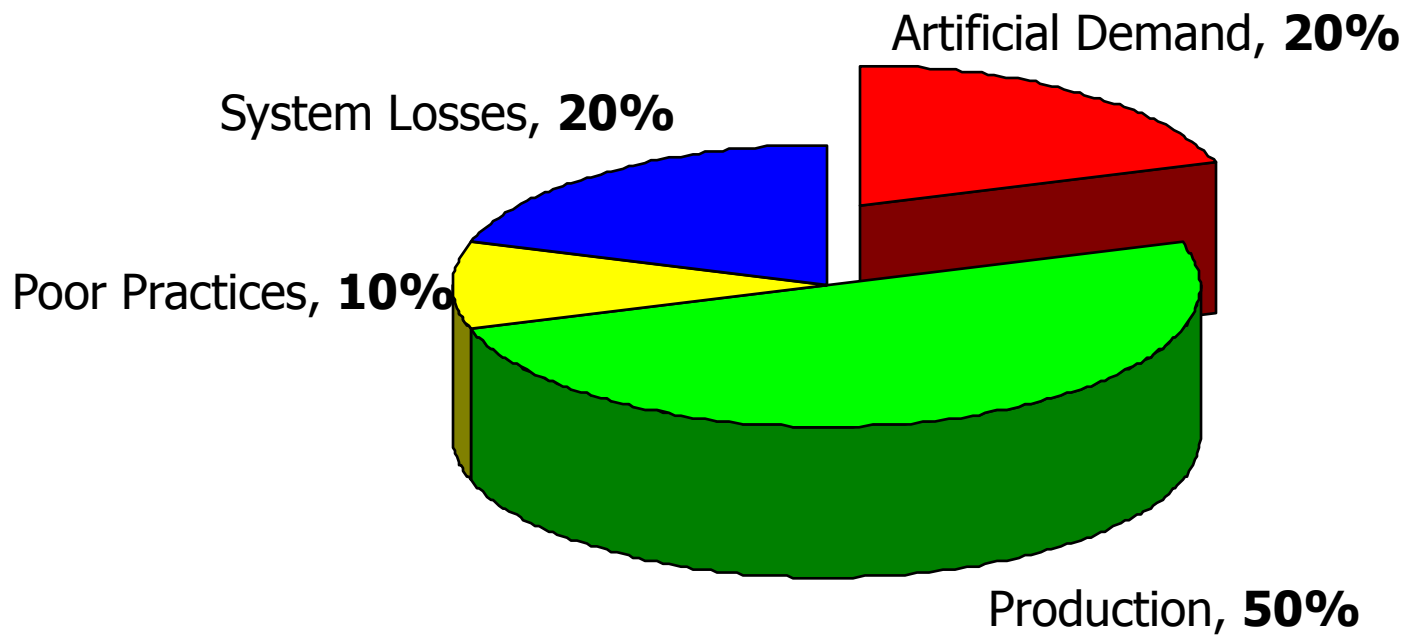

# Energy Losses

## Poor Practices Waste 10%!

- Using high pressure air for cleaning floors & machines
- Using high pressure air for washing of body (Safety Hazard)
- Using compressed air jets for cooling in hot weather
- Draining high pressure air along with condensate

# Energy Losses

## System Losses Waste 20%!!

- Pressure Loss in After Coolers, Moisture Separators
- Air leakages in joints & end connections
- Pressure Loss across Filters & Dryers
- Pressure Loss in Pipelines, Bends & Valves

Operating Air Compressors at higher pressure to overcome these losses!

# Energy Losses

## Artificial Demand Wastes 20%!!!

- Over Supply of Compressed Air
- Lack of Compressed Air Storage
- Uncontrolled End Use of Compressed Air
- Improper control of Air Compressors

Operating Air Compressors to meet  
Base Demand + Artificial Demand to  
meet Fluctuating Demand!

# What's the definition of Artificial Demand?

When an air application is supplied higher pressure than it needs, it will consume more air than it should. The additional air consumption is artificial demand. The effect of artificial demand can be demonstrated through the data available on fluid flow across an orifice...

- Reducing orifice size (i.e. leaks, etc.) reduces flow rate
- Reducing pressure reduces flow rate (Artificial Demand)

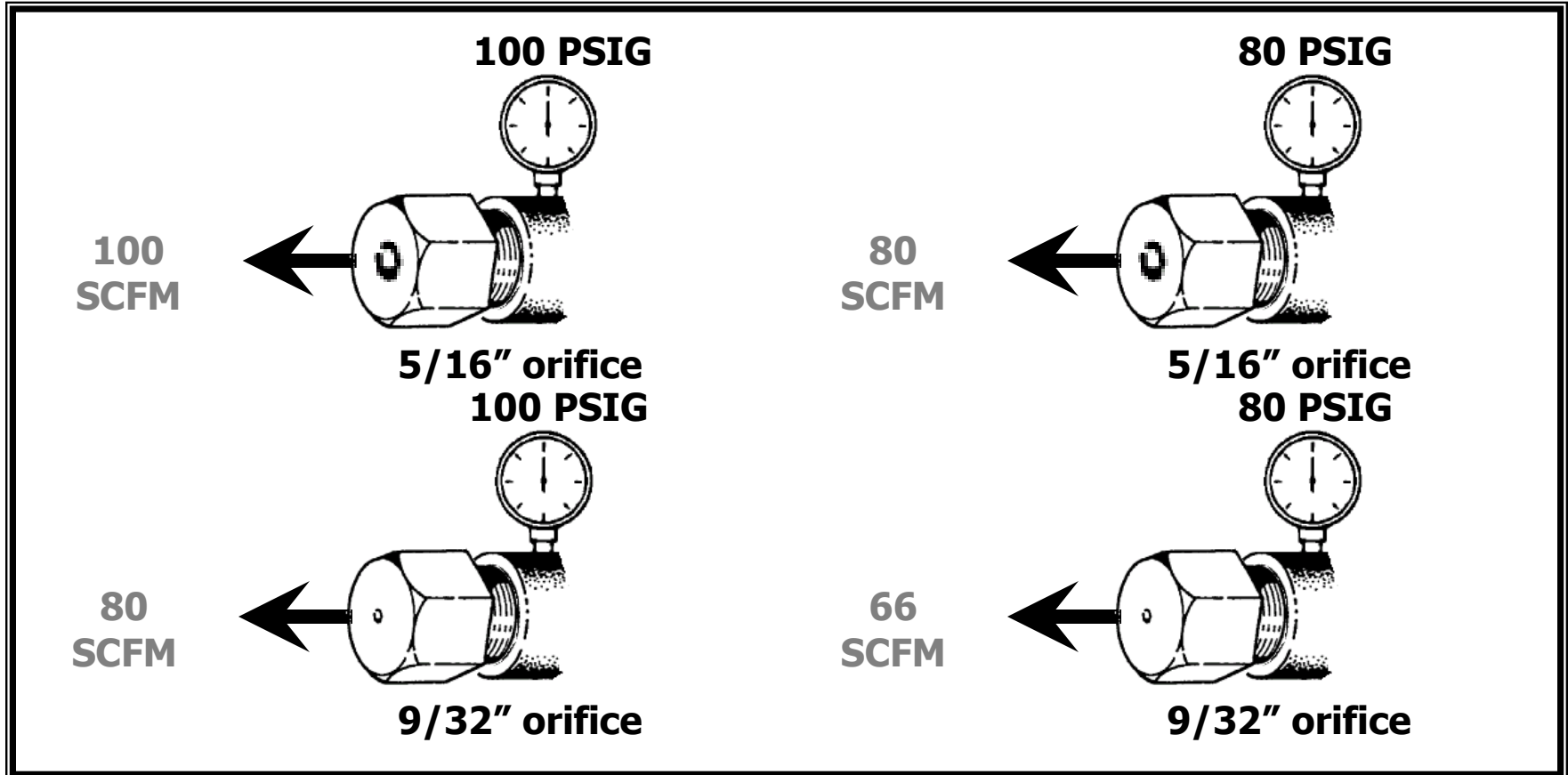

**Artificial demand causes leaks and productive air users to waste energy!**

An air cylinder that is specified to use 30 psig,  
will use 70% more air at 60 psig,  
230% more air at 90 psig and  
300% more air at 120 psig.

Virtually all air-powered equipment work this way –  
the more pressure delivered, the greater the air used.  
Auditors call this phenomenon artificial demand.

# Creating opportunities for Energy Saving

- **Reduce Air Demand: -**

- Convert pneumatic tools to hydraulic or electric tools
- Reduce air leakages
- Segregate airlines as per pressure & demand requirement
- Use Demand Side Control Systems

# Creating opportunities for Energy Saving

- **Control Compressor Operation:** -
  - Operate right combination of Compressors
  - Use right type of Capacity Control
  - Operate most efficient Compressors
  - Use Supply Side Control Systems & Monitoring

# Capacity Control in Air Compressors

## Positive Displacement (Recip, Screw):

- By On/Off
- By Load/Unload
- By Modulation
- By Geometry
- By Variable Speed

# Capacity Control in Air Compressors: Positive Displacement

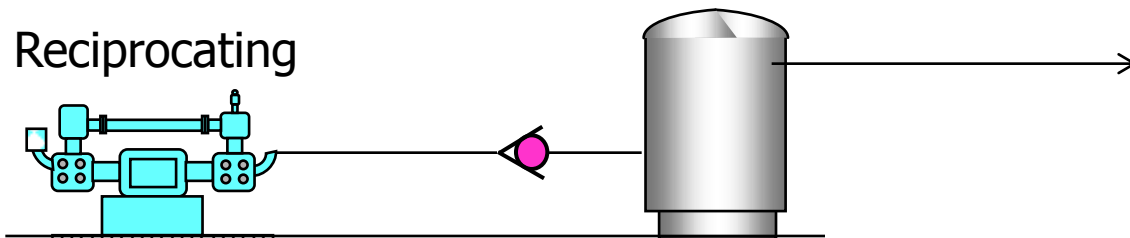

POWER: Unload kW = 20%; Load kW = 100%

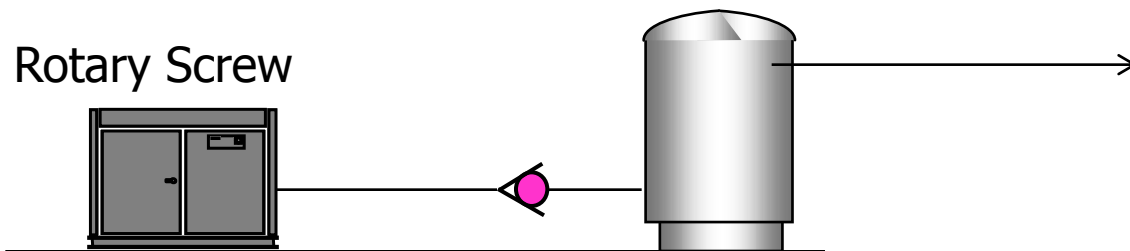

POWER: Unload kW = 35%; Load kW = 100%

# Capacity Control in Air Compressors: Positive Displacement

## Real Time Logging of Motor Current (Amps)

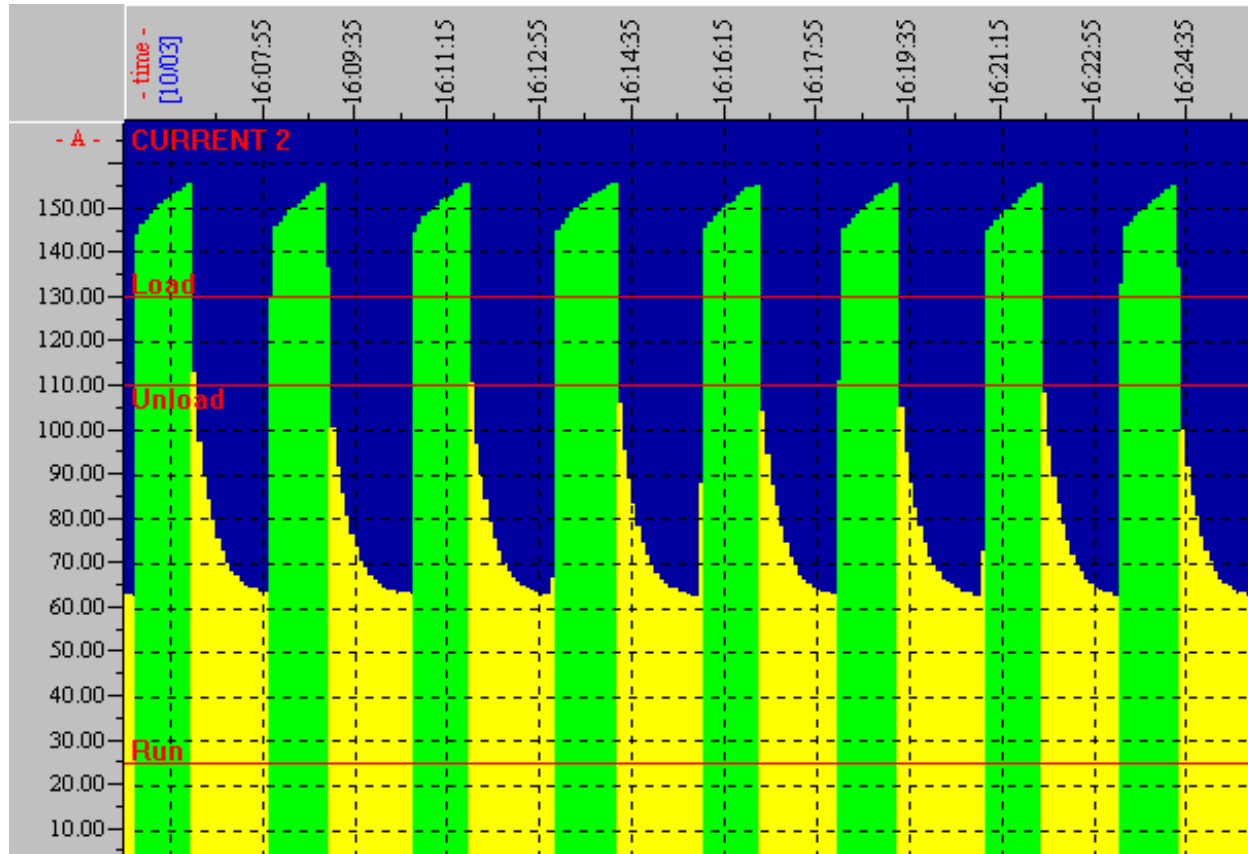

# Variable Capacity Control in Rotary Screw Comp (as Actual)

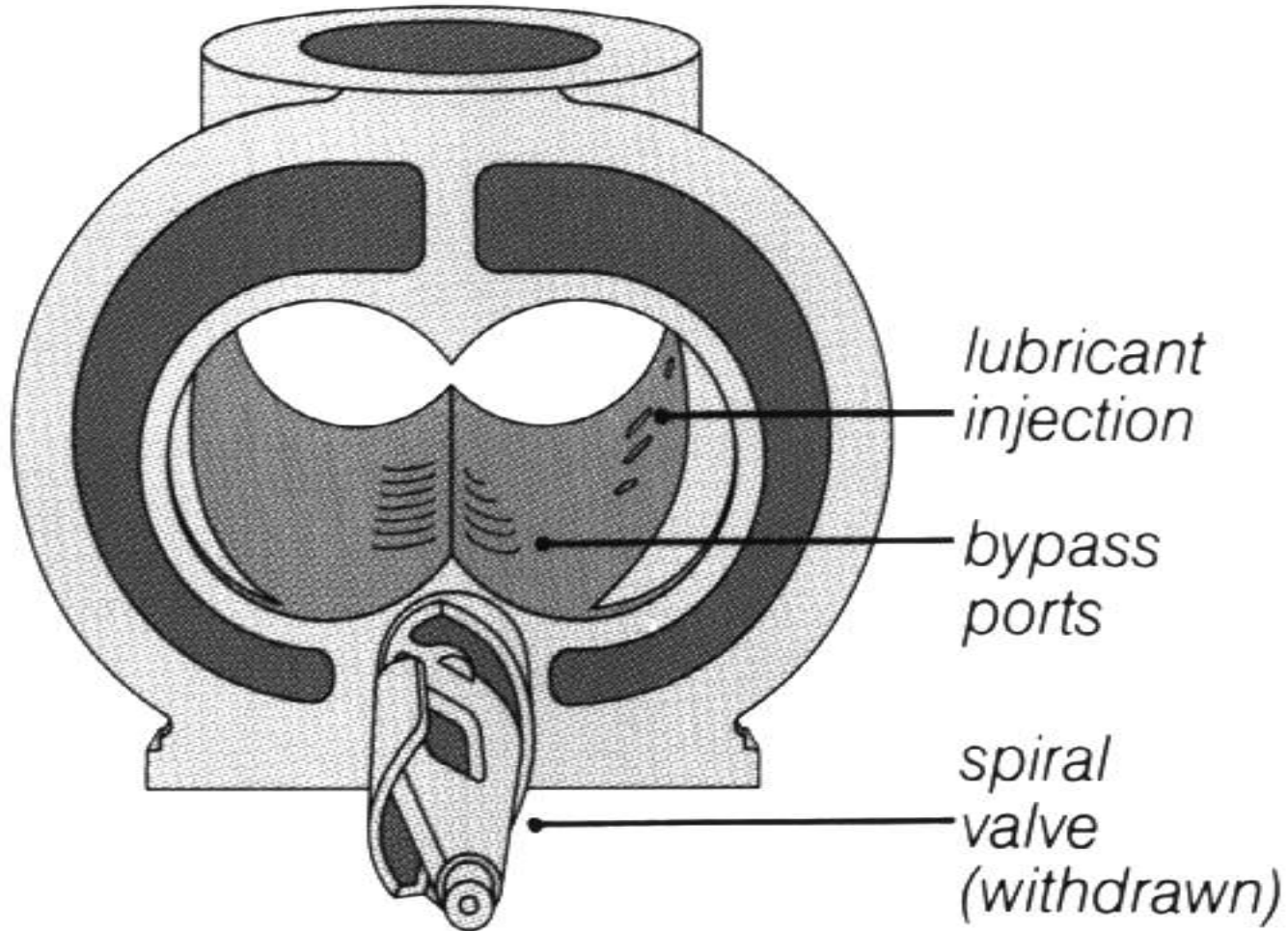

# Spiral Valve Control

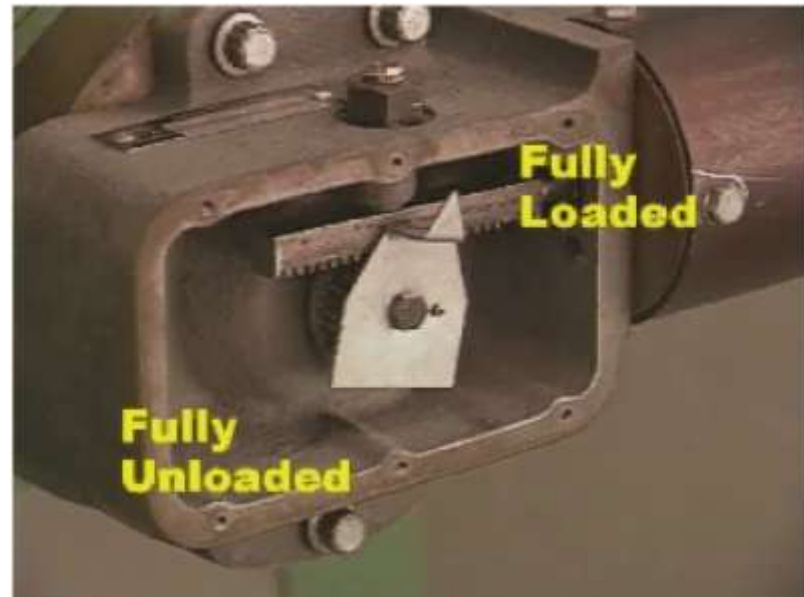
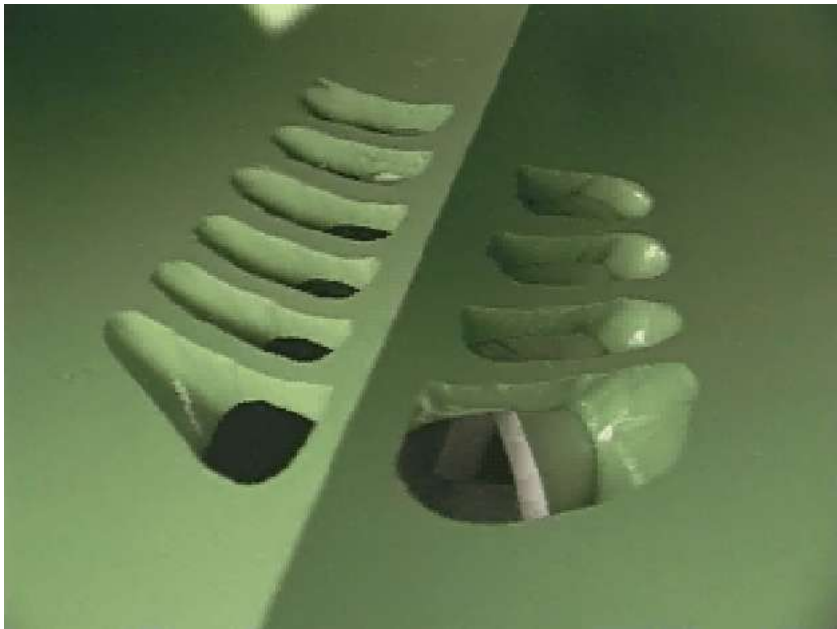
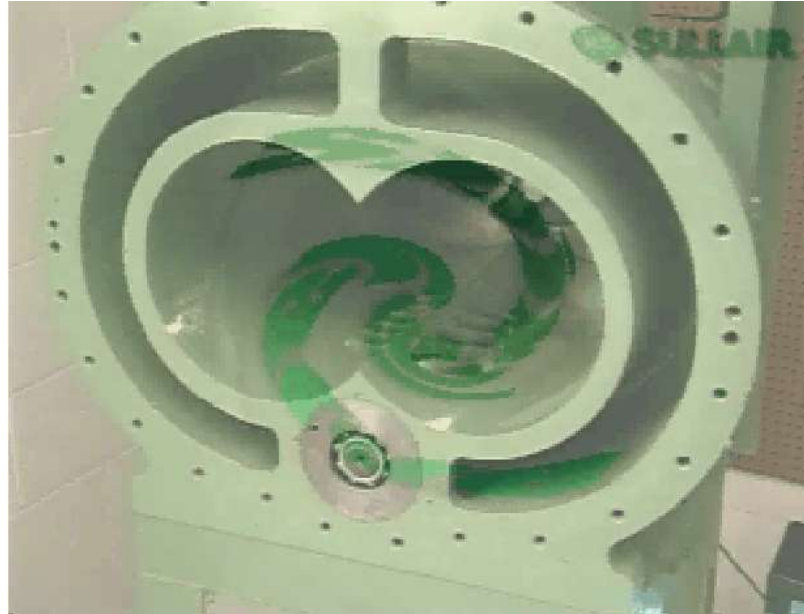

**CONTROLAIR**

**Demand Side**  
**Control Systems**

# Variations Compressed Air Pressure Real Time Data

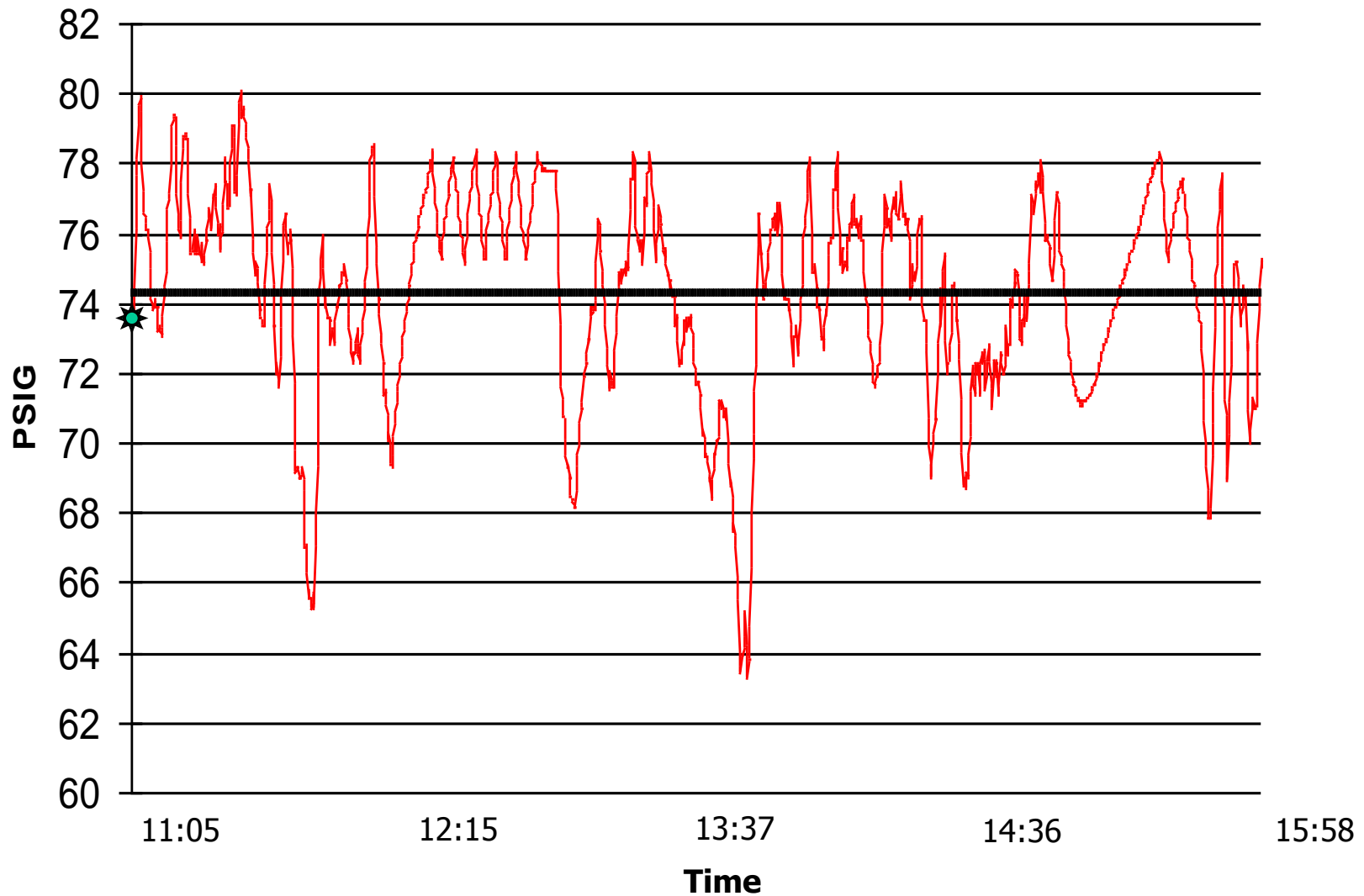



**Air In**

**Air Out**

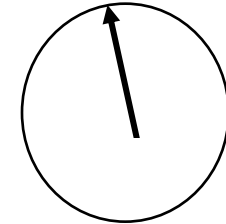
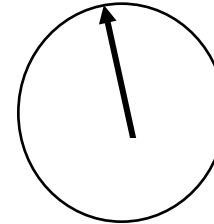

**On Load**

**On Load**

**Without IFC**

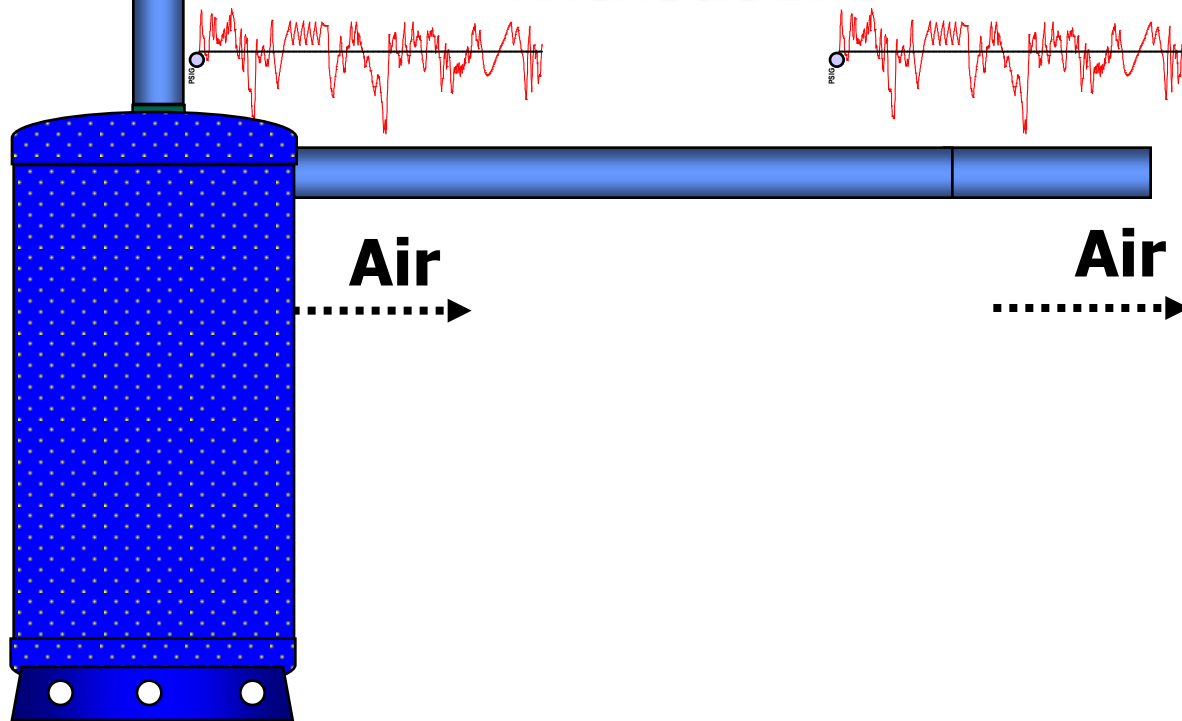

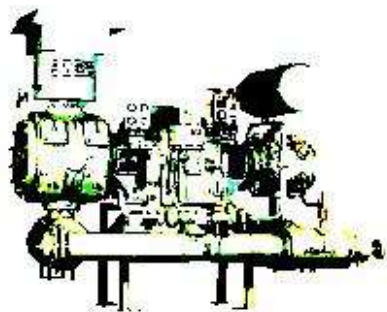

**Air In**

**Air Out**

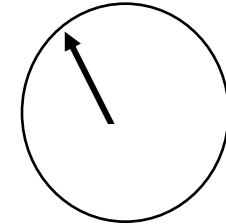
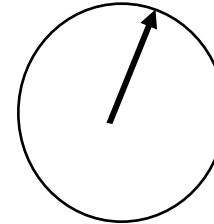

**On Load**

**Unload**

**IFC Online**

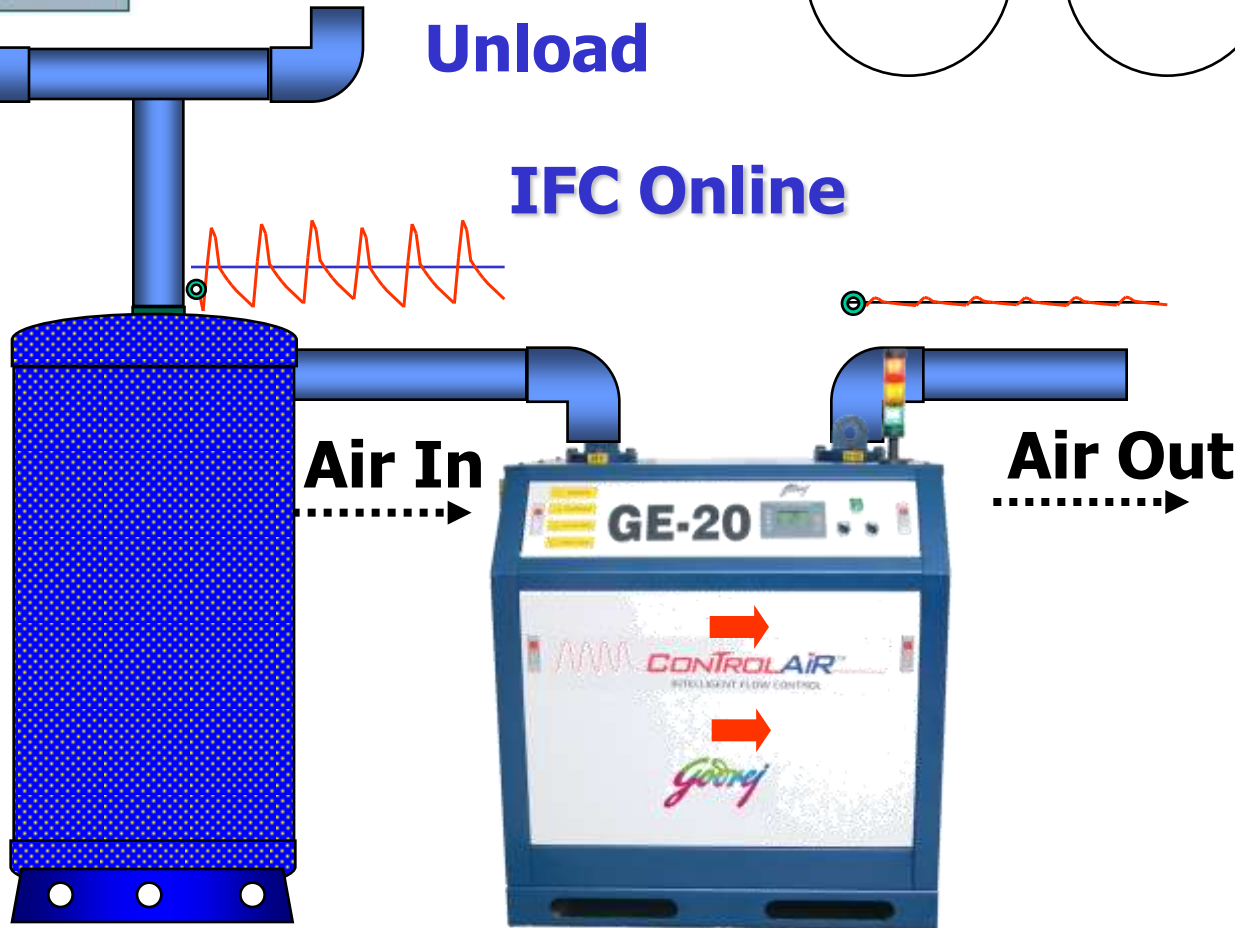

# Reduces Load Period of the Compressor – **CONTROLAIR**<sup>TM</sup> Gives Energy Savings

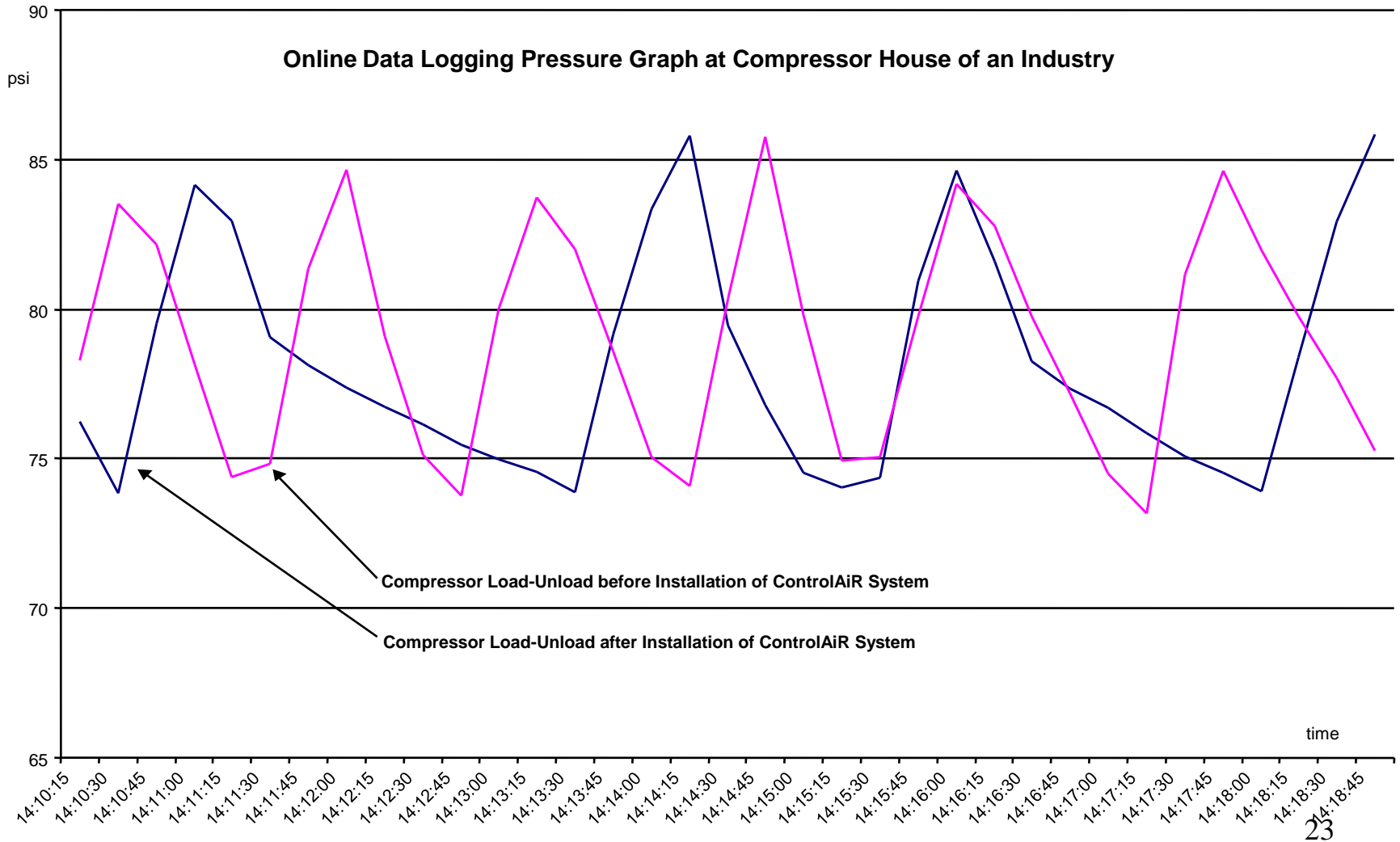

# Response Time of Compressors with VFD or Load/Unload capacity control to meet sudden air demand

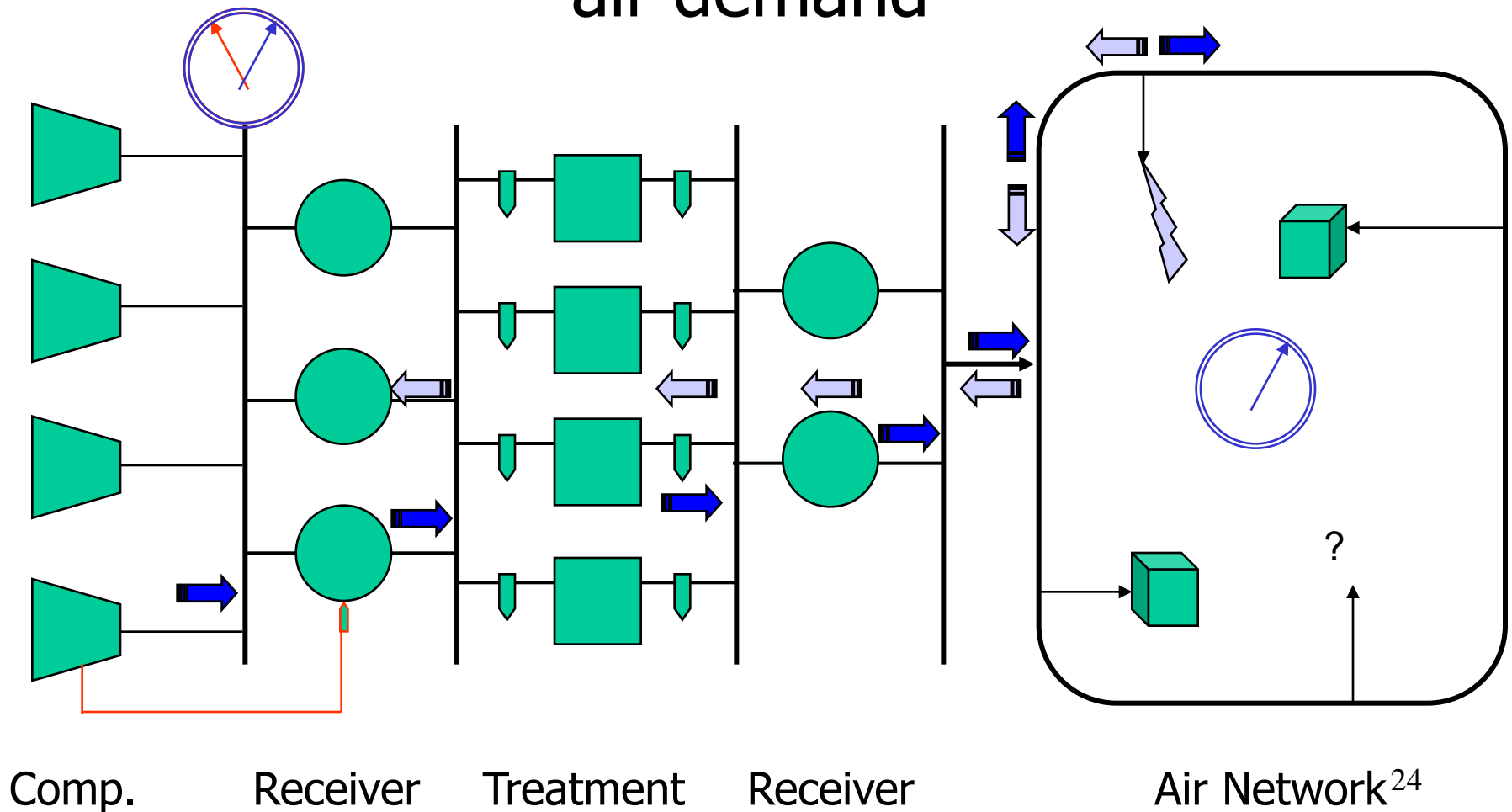

# ControlAIR Intelligent Flow Control (IFC) System

**Solution**

**PATENTED**



# Response Time of Compressors Control Air IFC System on-line to meet sudden air demand

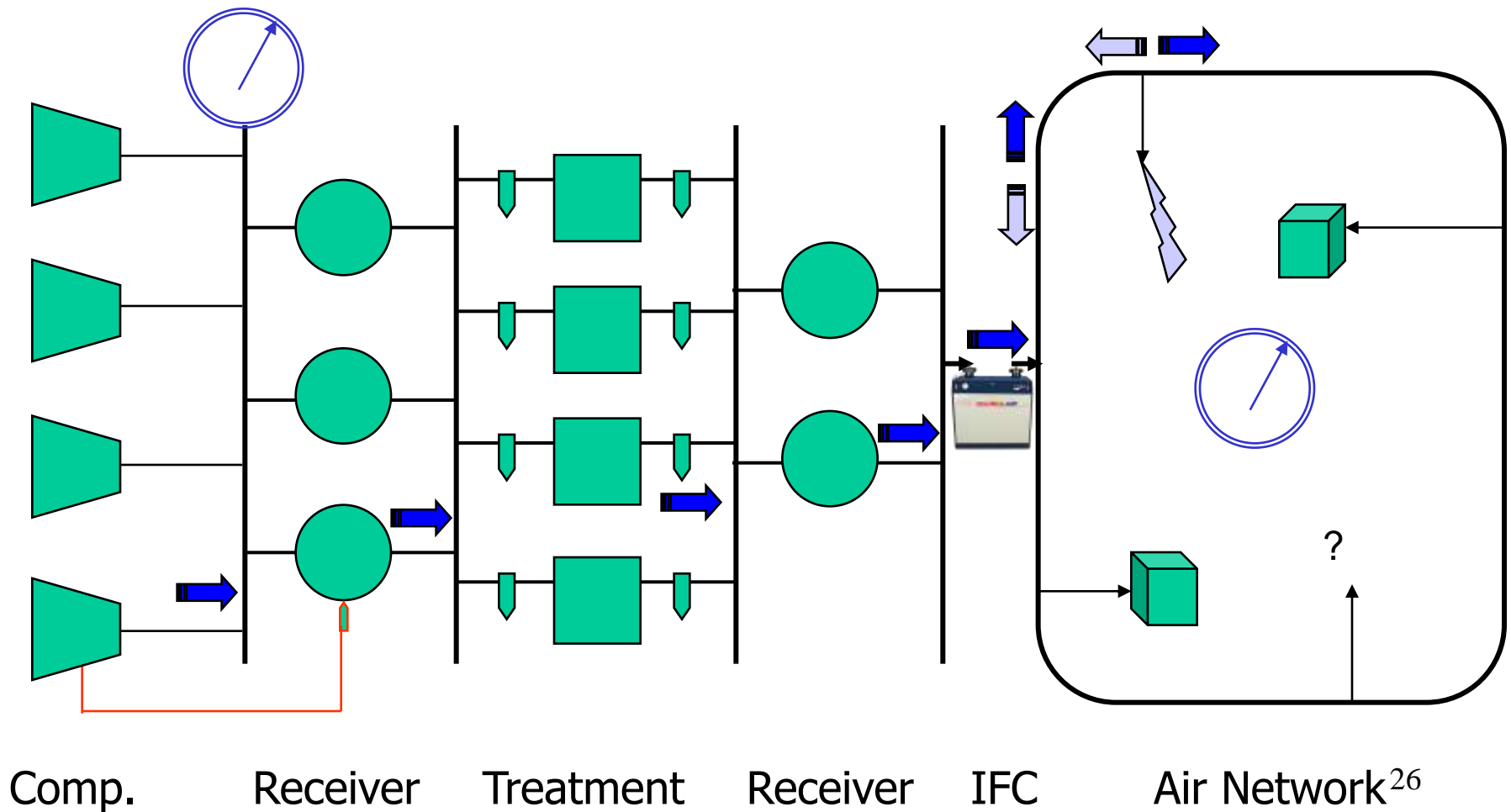



Confederation of Indian Industry  
CII - Sohrabji Godrej Green Business Centre

## National Award for Excellence in Energy Management 2008

*This is to certify that*

**"ControlAir Demand side Intelligent flow Control System  
for Energy Saving in compressed Air System"**  
product supplied by **"Godrej & Boyce Mfg Co Ltd, Mumbai"**

*Has been recognized as an "Innovative Energy Saving Product"*

*This is based on the details provided in the questionnaire and evaluation by the judges  
at the National Competition for Excellence in Energy Management  
held on 22 & 23 August 2008 at Pune.*

**L S GANAPATI**

Chairman  
National Award for  
Excellence in Energy Management

**Dr NAUSHAD FORBES**

Deputy Chairman  
CII - WESTERN REGION

# Supply Side Management for Energy Saving & Intelligent Control of Air Compressors



# Multiple compressor operation

- Much higher energy costs involved in case of multiple compressor installation
- A traditional multiple Compressor operation is complex to control

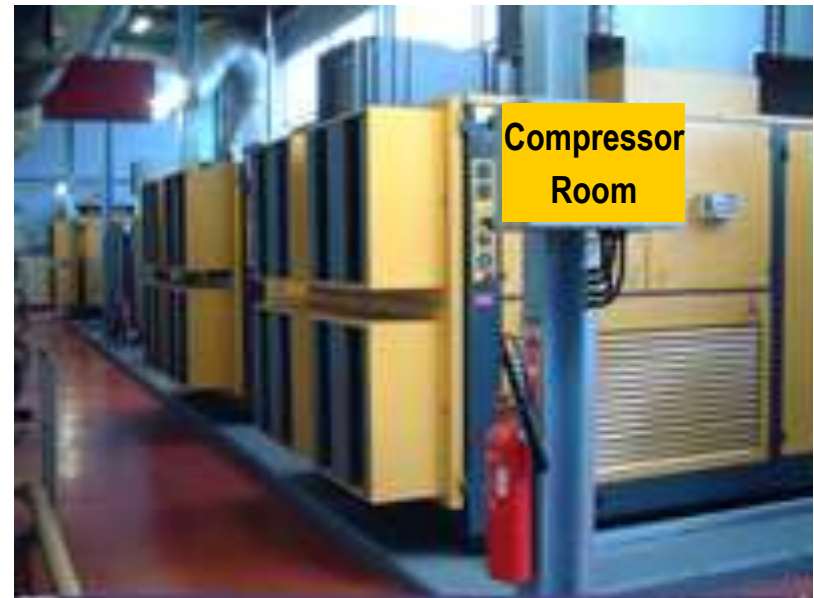

# Inherent Drawbacks -- Pressure

Utilising a number of individual pressure switches forces the system to produce compressed air at a pressure above that required.

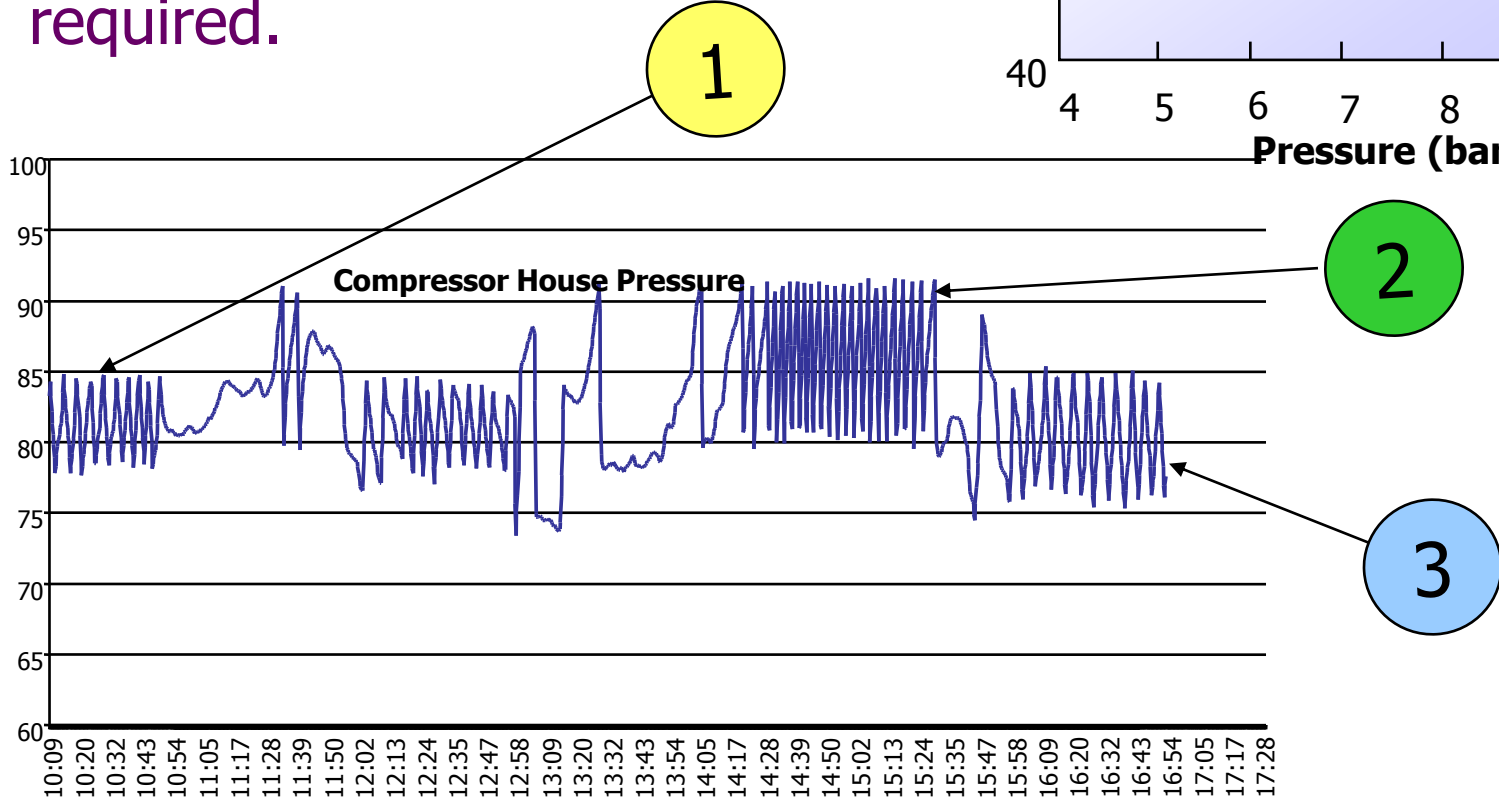
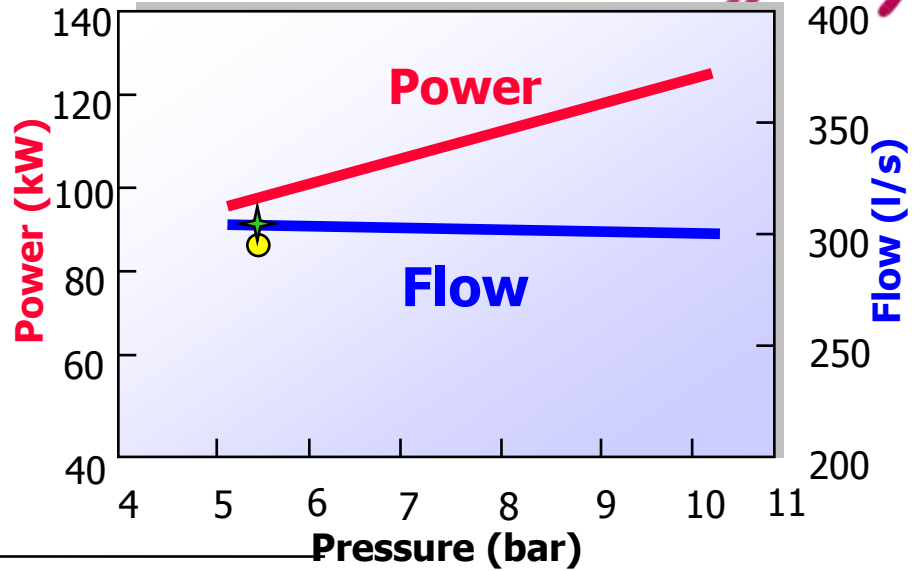

# metacentre

EnergAir

Godrej

## Metacentre SX & XC: Controls up to 12 & 24 Compressors



***Solution***

# Single Pressure Band Control with EnerAir SX

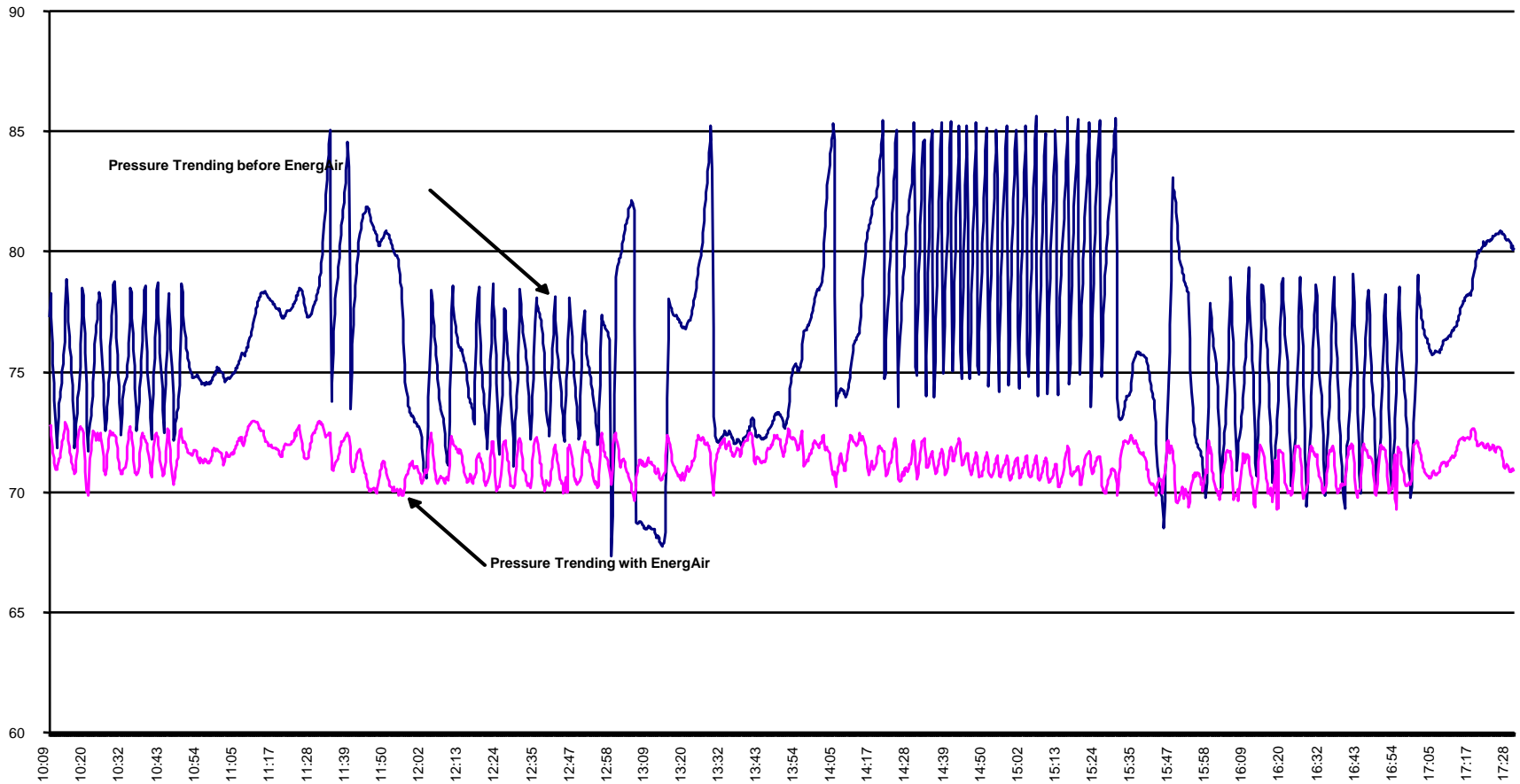

# EnergAir SX Operation Modes

## *Maximum Efficiency Mode*

Selects the most efficient combination of compressors to satisfy demand

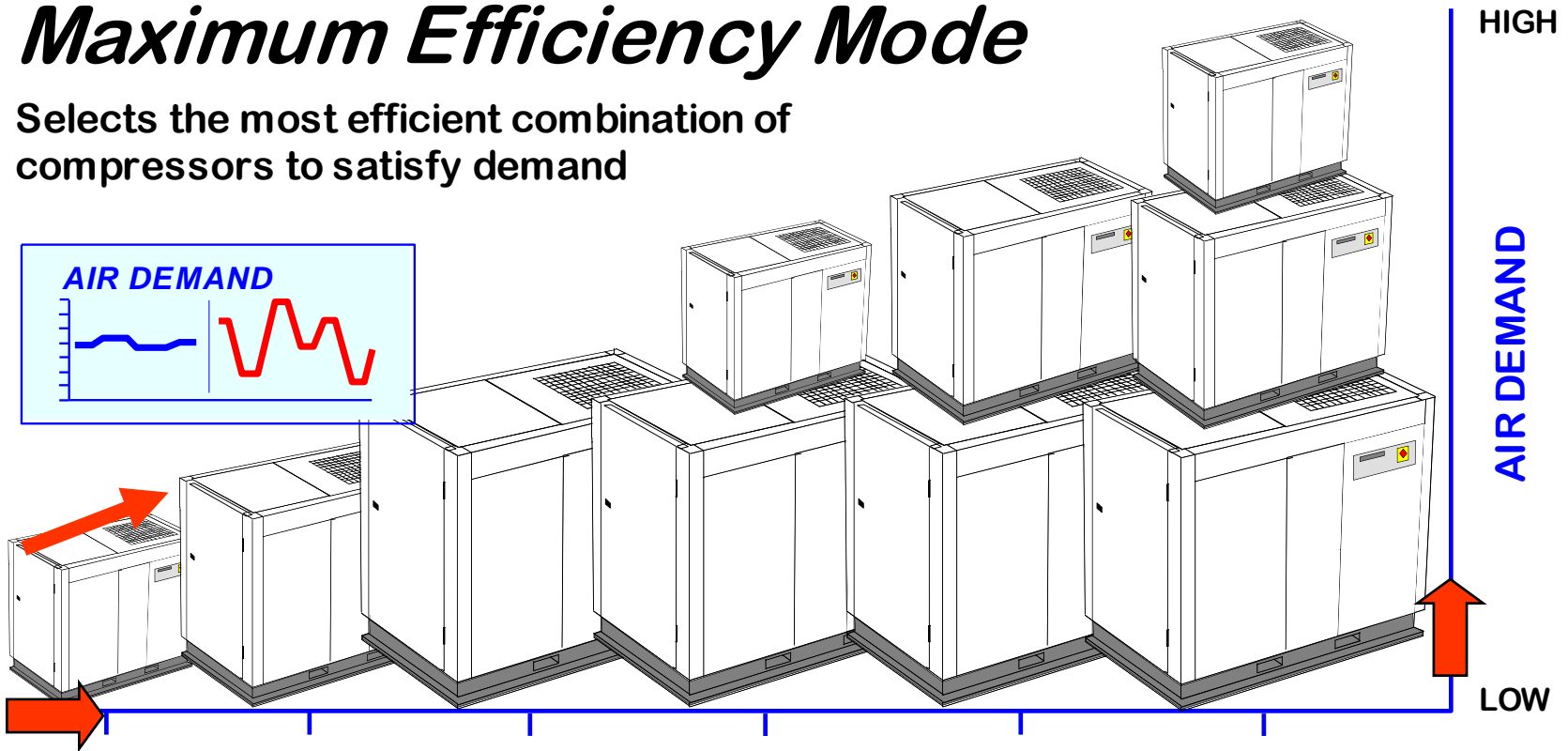

## Maximum Efficiency Mode

- In first few hours of commissioning, the SX memorises various events of air demand
- Monitors the effect of combination of compressors w.r.t. time taken to meet the demand
- Relates Compressor capacity to respond for every possible air demand
- Automatically tunes itself for most Energy Efficient sequence of Compressors

## I/O Box & Sensors for Monitoring of Status, Health of Air Compressors & System

- Each I/O Box enables connecting up to 4 analog & 8 digital sensors.
- Monitoring of Bearings (SPM™), Delta 'P', Temperature, Pressure, Flow, Dew Point etc.
- History & Pressure Trending

# Remote PC Visualisation of EnerAir SX



**EnerAir EnerSoft Pro - [Control Pressure]**

File Settings Info

**Enercon**

CAP

Compressor Fault 4

1 2 3 4 5 6 7

6.4 bar

Control Pressure (10 mins)

Efficiency Indicator

# Remote PC Visualisation of EnerAir SX



## Compressor Run Hrs & Service Reminders

**EnergAir EnerSoft Pro - [Compressor Hours Run]**

File Settings Info

**Enercon**

CAP

Compressor Fault 4

Compressor	Hours Run	Service Interval	Next Service Due
Compressor 1	13924 hrs	1500 hrs	14205 hrs
Compressor 2	17684 hrs	1500 hrs	18727 hrs
Compressor 3	17270 hrs	1500 hrs	18663 hrs
Compressor 4	10532 hrs	20000 hrs	35000 hrs
Compressor 5	985 hrs	1500 hrs	2278 hrs
Compressor 6	1177 hrs	1500 hrs	2465 hrs
Compressor 7		0 hrs	0 hrs

Efficiency Indicator

# Remote PC Visualisation of EnerAir SX



## Daily / Weekly Flash Report

EnerAir EnerSoft Pro - [Control Pressure]

File Settings Info

**EnerSoft FlashReport**

Pressure

Activity

Filtering

ON  OFF

**EnerSoft FlashReport - Key Performance Indicators**

Date : Fri 12 Dec 2003

Period : 12 hrs ( 12 hrs )

Compressor	1	2	3	4	5	6	7	8	9	10	11	12
%Run :	36	100	35	-	25	86	-	-	-	-	-	-
%Load :	36	56	30	-	21	81	-	-	-	-	-	-

System	Average	Total
Input :	371.5 kW	4458 kWh
Output :	53.1 m <sup>3</sup> /min	38246 m <sup>3</sup>
Efficiency :	6.994 kW/m <sup>3</sup> /min	6.994 kWh/m <sup>3</sup>

# Capabilities of EnerqAir System:

- Suitable for all types & makes of Air Compressors
  - Total Control of Battery of Compressors
    - Single Pressure Band Control
- Programmable Timer Control (FIFO & Timer Rotation)
  - Capacity Matched Sequencing
  - Compressor Priority Sequencing
  - 28 Pressure Scheduling per week
- Assign Pre-fill time & Pre-fill Compressors
- Modular Assembly to facilitate future Expansion
  - Monitoring of Auxiliary of Compressors
    - Variable Speed Compatible
    - Remote Monitoring Option

# Case Study-1

## Power Plants Supply & Demand Side Control System



# **Installations of IFCs in Power Plants**

## Air Compressors of Large & Medium Capacity used in Power Plants

- **Service Air** : Wet & Lubricated air is acceptable
  
- **Instrument Air** : Dry & filtered Lubricated air is acceptable

# **Case Study - 1**

## **THERMAL POWER PLANT**

### **IFC - Demand Side Control Systems**



**TATA**

**TATA POWER CO. MUMBAI 500 MW**



## **ENERGY CONSERVATION IN POWER PLANT AUXILIARIES**

## Compressed air in Unit #5 (500 MW)

- Compressor Capacity 215 HP each
- Quantity 6 nos. installed
- Utility combination of 3 compressors per shift
- Total rated Scfm at installed base 4500 Scfm
- Total running Scfm 2250 Scfm
- Rate of Electricity Rs. 2 / kWh
- Working days per year 365
- Compressed air energy consumption 9331 kWh/Day

# TATA THERMAL POWER PLANT

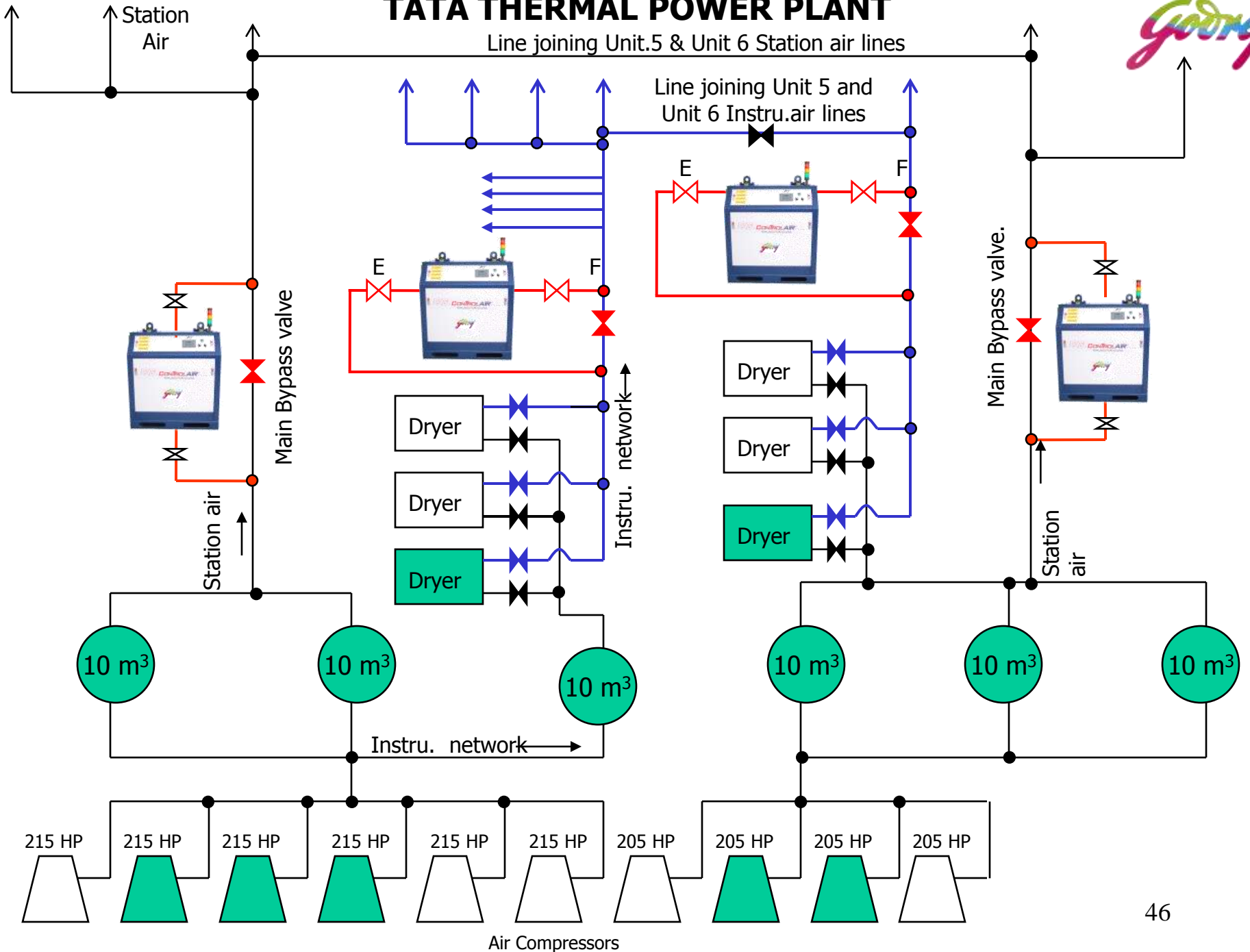

## Executive Summary for Unit 5

- Present average daily energy consumption 9,331 kWh/day
- Daily Energy Saving projected (@9%) 864 kWh
- Annual Energy cost saving Rs. 6,17,580  
(365 days@ Rs. 2 per kWh)
- Constant pressure throughout the header within 1 psig

## On-line Pressure Chart Without & With IFC on Customer's SCADA

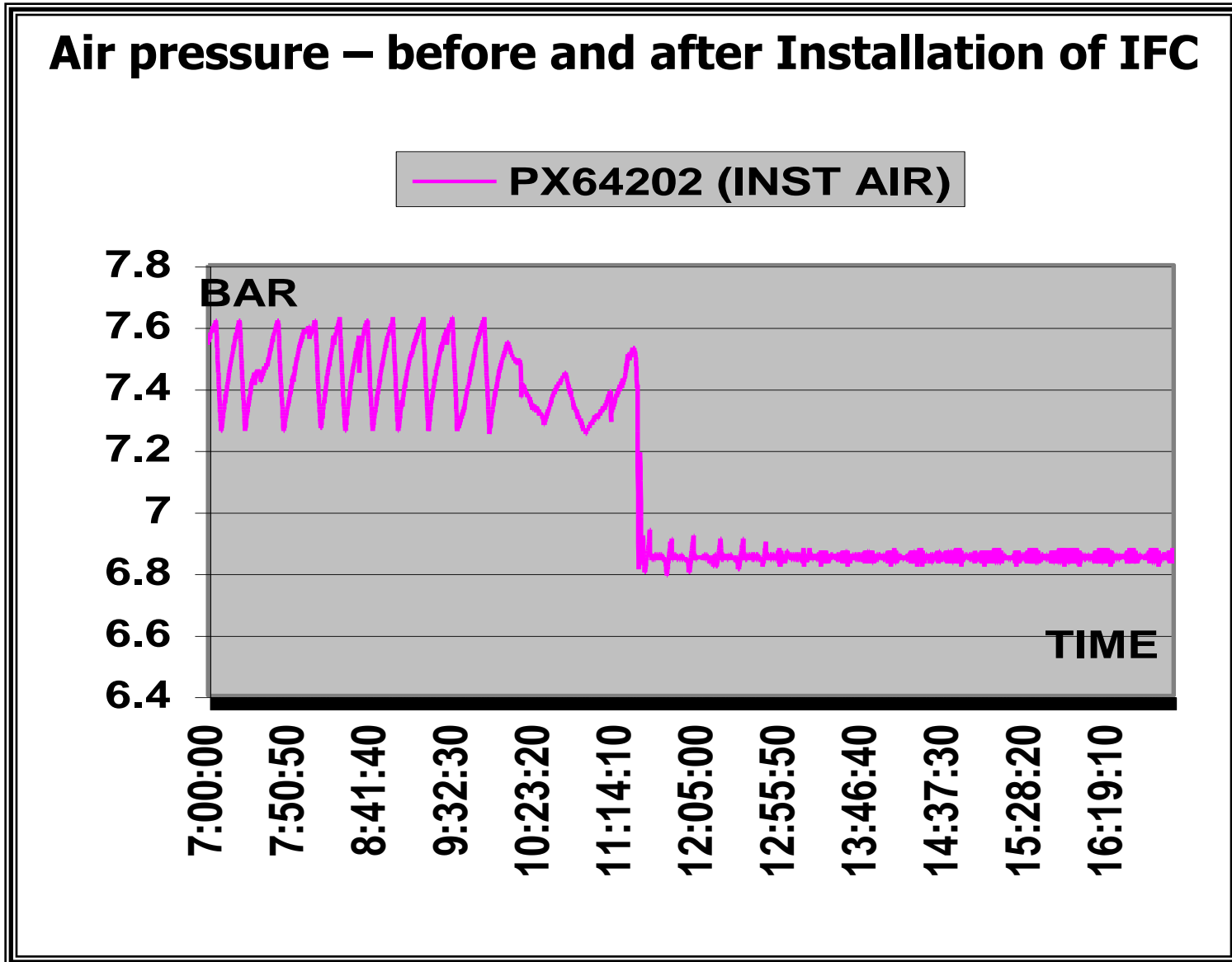

## INSTALLATION OF IFC IN POWER PLANT

### Original case

- ◆ Pressure of Control and Instrument Air of 500 MW Unit was varying from 7.2 to 7.6 bar. Air pressure is maintained by loading / unloading of compressors.

### Modification done

- ◆ IFCs have been installed which maintain Instrument Air pressure at 6.84 bar & Station Air pressure at 6.43 bar
- ◆ Optimised steady pressure leads to reduction in Auxiliary Power

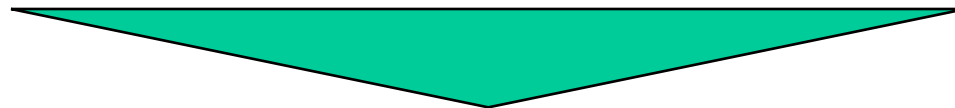

**Savings per year**

**Rs. 11 lacs**

# Case Study - 2

## THERMAL POWER PLANT

### IFC - Demand Side Control Systems

# IB THERMAL POWER PLANT COMPRESSOR HOUSE LAYOUT

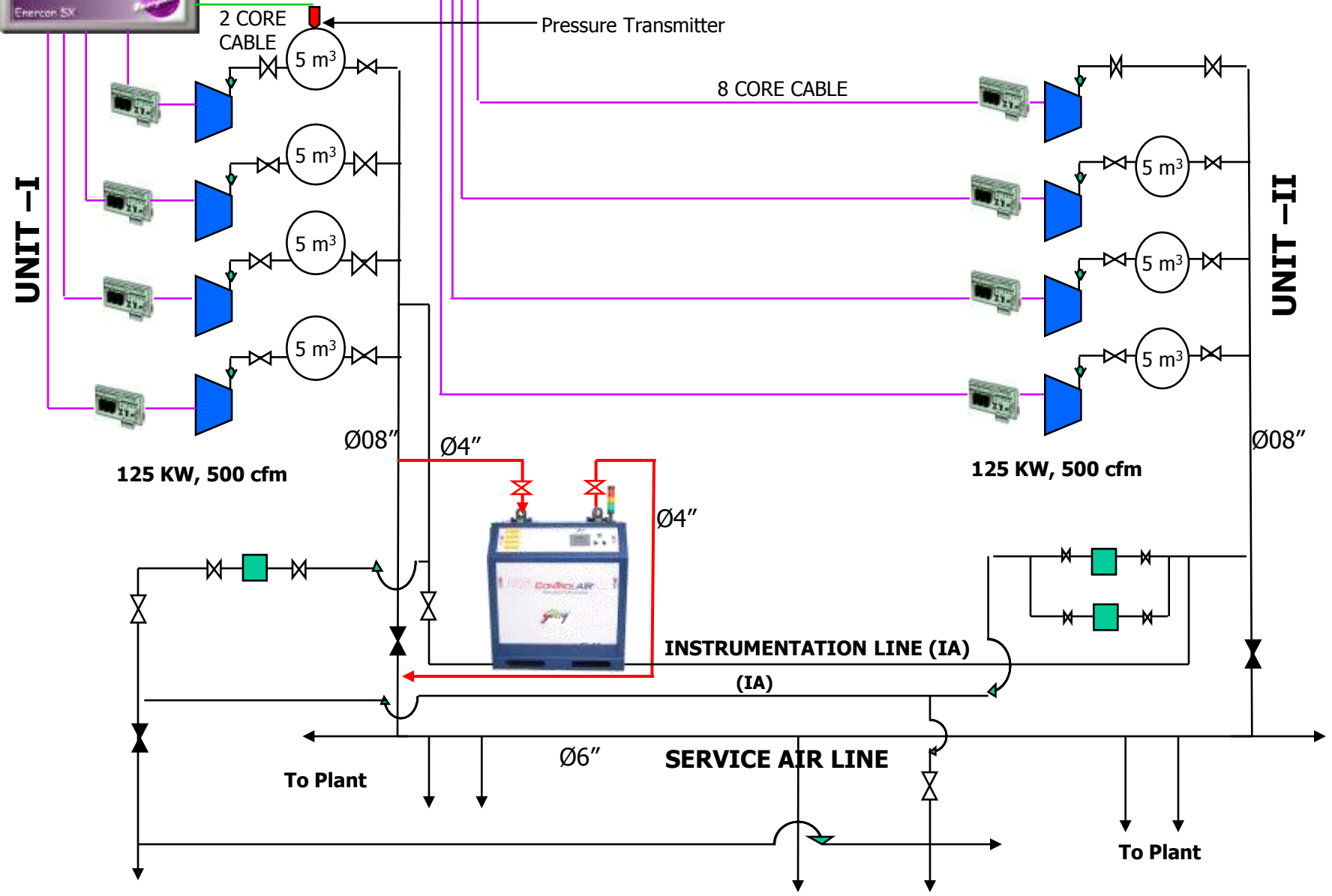

**Symbols:-**

- Compressor
- Valve Closed
- Valve Open
- Receiver
- Dryer
- NRV
- EARLIER LINE
- MODIFIED LINE

IB THERMAL POWER PLANT  
**Benefits with IFC**



**Without IFC**

- Energy Consumption: 10,200 kWh/day
- Compressors run: 5 numbers
- Pressure Variation: 100 psig to 107 psig

**With IFC**

- Energy Consumption: 9,435 kWh/day
- Compressors run: 4 numbers
- Pressure Variation: 83 psig

Energy Savings per day = 765 kWh/day @ 7.5%

Constant Pressure within +/- 0.2 psig

# Case Study - 3

## THERMAL POWER PLANT

### IFC - Demand Side Control Systems

Vikram Cement TPP  
**Benefits with IFC**



**Without IFC**

- Energy Consumption: **4694** kWh/day
- Compressors run: 3 numbers
- Pressure Variation: 95 psig to 105 psig

**With IFC**

- Energy Consumption: **2700** kWh/day
- Compressors run: 2 numbers
- Pressure Variation: 87 psig

Energy Savings per day = 1995 kWh/day @ 42.5%

**Constant Pressure within +/- 0.2 psig**

# Case Study - 4

## THERMAL POWER PLANT

### IFC - Demand Side Control Systems

# Earlier Layout of Compressed Air Network at Reliance Energy

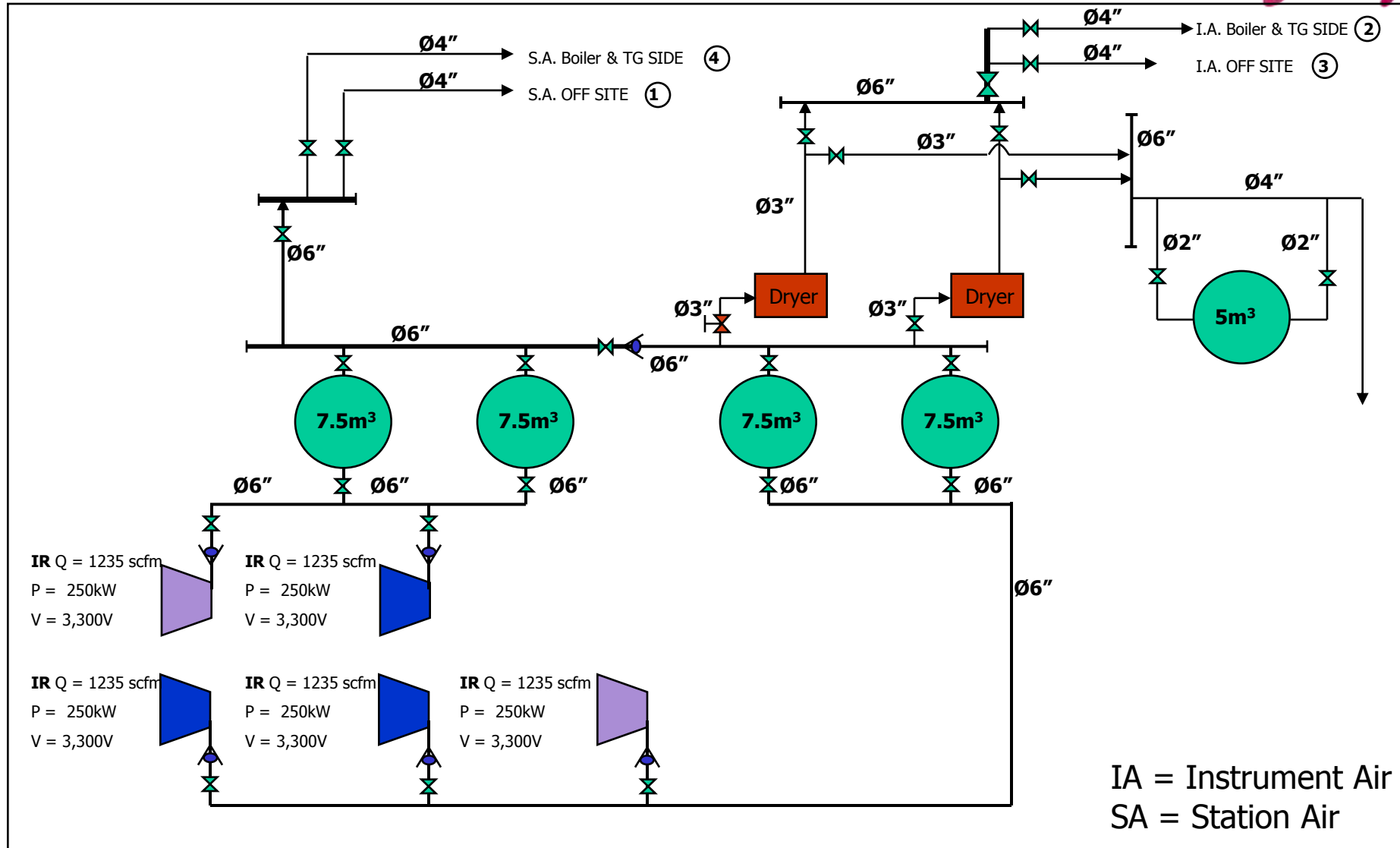

IR Q = 1235 scfm  
P = 250kW  
V = 3,300V

IR Q = 1235 scfm  
P = 250kW  
V = 3,300V

IR Q = 1235 scfm  
P = 250kW  
V = 3,300V

IR Q = 1235 scfm  
P = 250kW  
V = 3,300V

IR Q = 1235 scfm  
P = 250kW  
V = 3,300V

IA = Instrument Air  
SA = Station Air

	<b>Running Compressor</b>		<b>Stand by Compressor</b>		<b>Receiver</b>		<b>Dryer</b>		<b>Valve open</b>		<b>Valve Close</b>
--	---------------------------	--	----------------------------	--	-----------------	--	--------------	--	-------------------	--	--------------------

# Modified Layout of Compressed Air Network at Reliance Energy

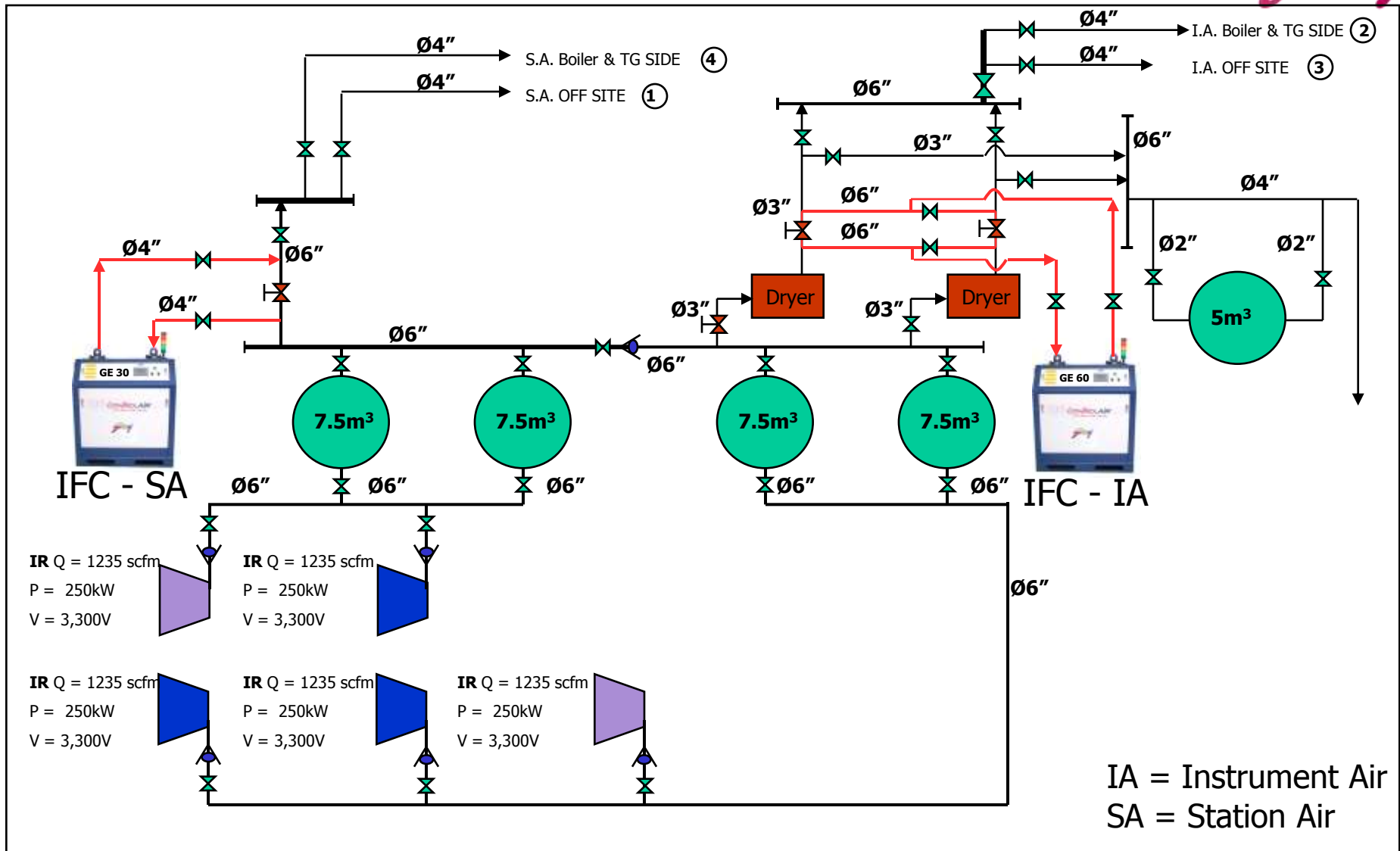

IA = Instrument Air  
SA = Station Air

	<b>Running Compressor</b>		<b>Stand by Compressor</b>		<b>Receiver</b>		<b>Dryer</b>		<b>Valve open</b>		<b>Valve Close</b>
--	---------------------------	--	----------------------------	--	-----------------	--	--------------	--	-------------------	--	--------------------

## Benefits of energy saving & constant air pressure

- *Daily Energy Consumption* : 10,694 kWh
- *Daily Energy Savings* : 749 kWh (@ 7%)
- *Daily Cost Savings (@ Rs. 3.50/kWh)* : Rs. 2,620/-
- *Annual Savings (365 days)* : Rs **9.56 Lacs**

# Case Study - 5

## THERMAL POWER PLANT

### IFC - Demand Side Control Systems

GMR Energy Limited  
**Benefits with IFC**



**Without IFC**

- Energy Consumption: **3252** kWh/day
- Compressors run: 2 numbers(3<sup>rd</sup> Compressor used intermittently)
- Pressure Variation: 95 psig to 115 psig

**With IFC**

- Energy Consumption: **3044** kWh/day
- Compressors run: 2 numbers(3<sup>rd</sup> Compressor not required)
- Pressure Variation: 90 psig

Energy Savings per day = 208 kWh/day @ 6.39%

Constant Pressure within +/- 0.25 psig

# Pressure Trending Before and After ControlAir system in GMR Energy Limited

Inlet & Outlet Pressure of ControlAir When system is Online.

- Constant Air Pressure of  **$\pm 0.75$ psig** (when pulsing was on)
- Constant Air Pressure of  **$\pm 0.25$ psig** (without pulsing)

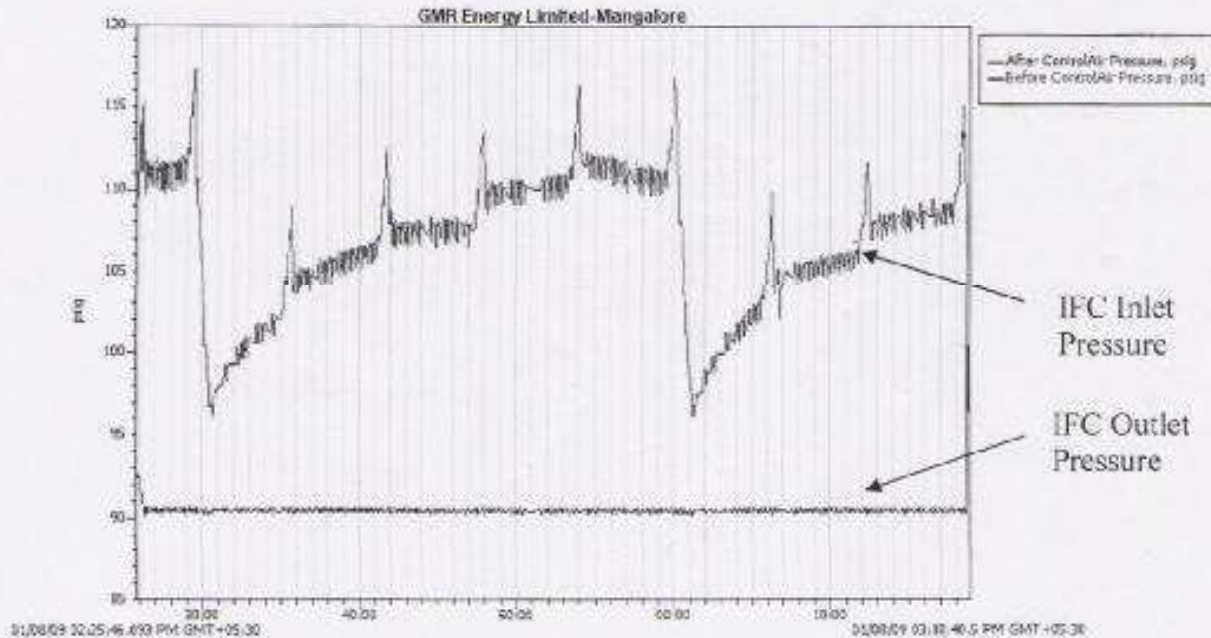

# Our Approach

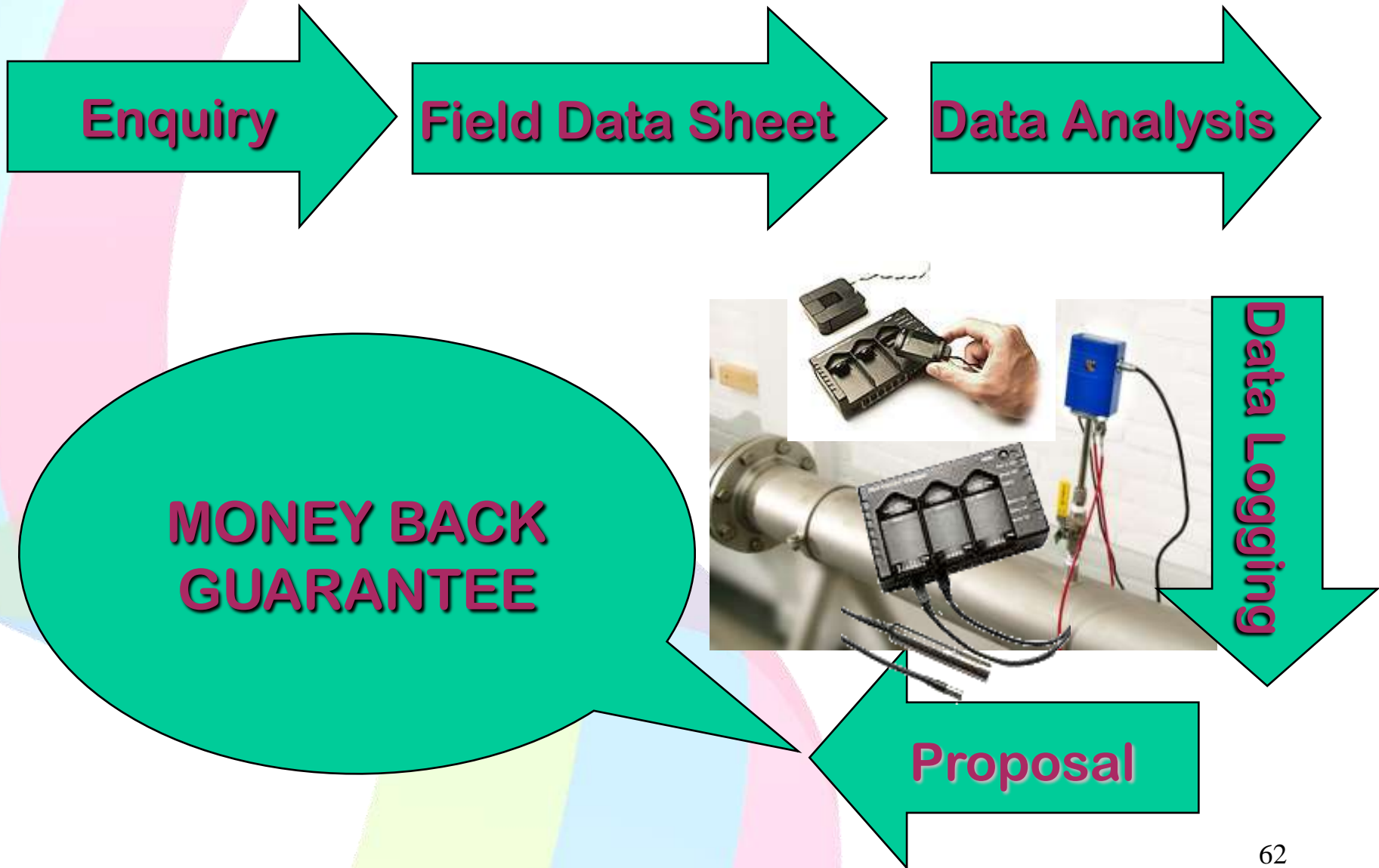

# Thank You!

## **Godrej & Boyce Mfg Co Ltd**

Compressed Air Solutions

E&E Division, Plant 1

PirojshaNagar, Vikhroli, Mumbai – 400079.

Tel.: +91-22-67962251 to 2255

Fax: +91-22-67961525

E-mails: [kcp@godrej.com](mailto:kcp@godrej.com); [jayraj@godrej.com](mailto:jayraj@godrej.com);  
[roshe@godrej.com](mailto:roshe@godrej.com); [manral@godrej.com](mailto:manral@godrej.com)

Website: [www.godrej-air solutions.com](http://www.godrej-air solutions.com)