



**Armstrong**<sup>®</sup>

Intelligent System Solutions<sup>®</sup>

STEAM • AIR • HOT WATER

# Welcome to Armstrong

Armstrong International, Inc.  
816 Maple Street  
Three Rivers, MI 49093  
Ph: 269-273-1415  
[www.armstronginternational.com](http://www.armstronginternational.com)

# Armstrong International, Inc.



## Five Generations of Family Ownership and Leadership

Adam Elliott Armstrong  
Lawrence F. "Army" Armstrong  
Merrill H. "Gus" Armstrong  
David M. Armstrong  
Kurt Armstrong



Global leader in energy and environmental management



Specialists in utility optimization for process, industrial, and institutional facilities



Global network of sales engineers and energy training facilities located in 60 countries



Operate 12 manufacturing facilities located in North America, China, Europe, Japan, India, Mexico and Korea

# Armstrong Promise

We provide intelligent system solutions that improve utility performance, lower energy consumption, and reduce environmental emissions . . . while providing an “enjoyable experience”!



Intelligent System Solutions® STEAM • AIR • HOT WATER

“Expect many enjoyable experiences!”

David M. Armstrong

# Promise Kept....every second...

- Since 2004, when we authored the UN recognized methodology for steam system carbon trading....
  - Armstrong saves 1 ton of CO<sub>2</sub> every 13 seconds
  - Armstrong saves 1 ton of energy every 40 seconds
  - Armstrong saves 10 tons of water every 3 seconds

....globally....



## Energy Audits – System wide

Have conducted *thousands of system audits* that have recognized upgrade ideas saving millions of \$'s in energy at customer sites



## Operations and Maintenance

Operate, maintain, and/or service multiple facilities globally that have lowered operational costs at each facility. Terms: 3-25 years

# Service Solutions



## Financed Optimization (specific projects)

Have *financed millions of \$'s of energy projects*



## Turnkey Construction and Project Management

Have implemented *hundreds of turnkey energy conservation projects* where Armstrong provided the talent and manpower to install project ideas and mitigate cost overruns



## Utility Monetization (utility asset ownership)

20 Global facilities owned and/or operated by Armstrong

## Steam and Condensate Solutions

## Solutions

# Steam and Condensate Solutions

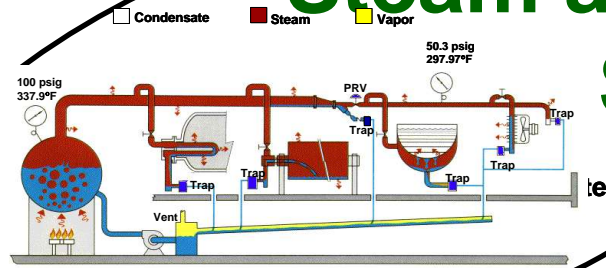

Steam Vapor

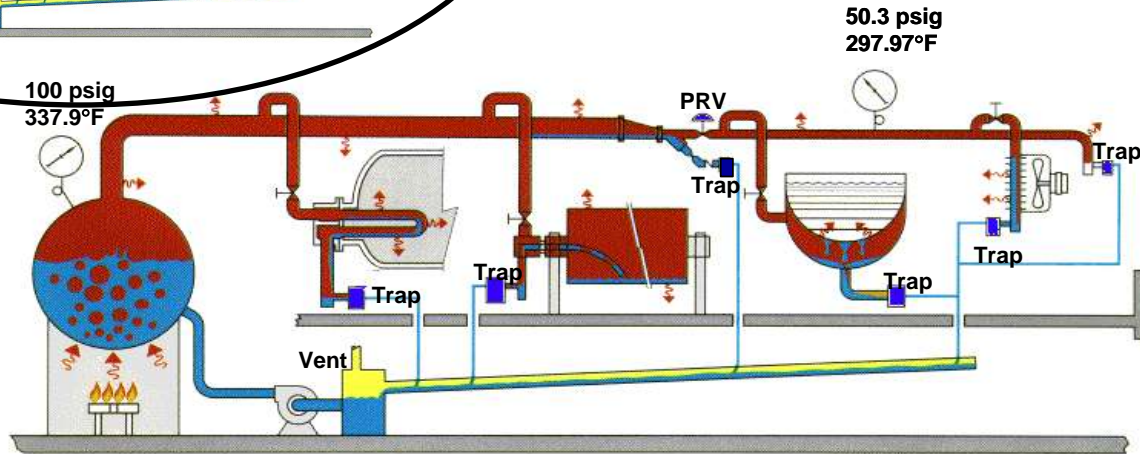

and Air Drainers

# STEAM SYSTEM SOLUTION FROM ARMSTRONG

## STEAM TRAPS



## PRV'S



Intelligent System Solutions® STEAM • AIR • HOT WATER

"Expect many enjoyable experiences!"

David M. Armstrong

# CONDENSATE SOLUTION FROM ARMSTRONG

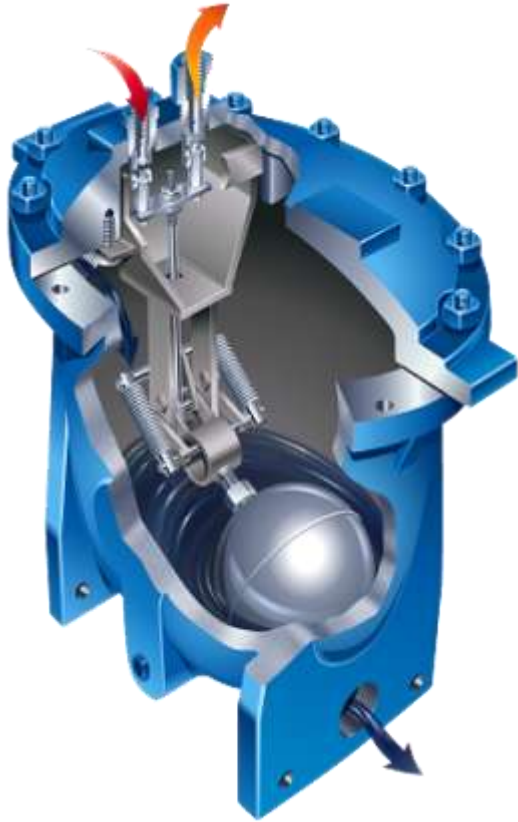

Intelligent System Solutions® STEAM • AIR • HOT WATER

"Expect many enjoyable experiences!"

David M. Armstrong

Hot Water Solutions

# Water Solutions

Heaters

Water Heaters

Changers

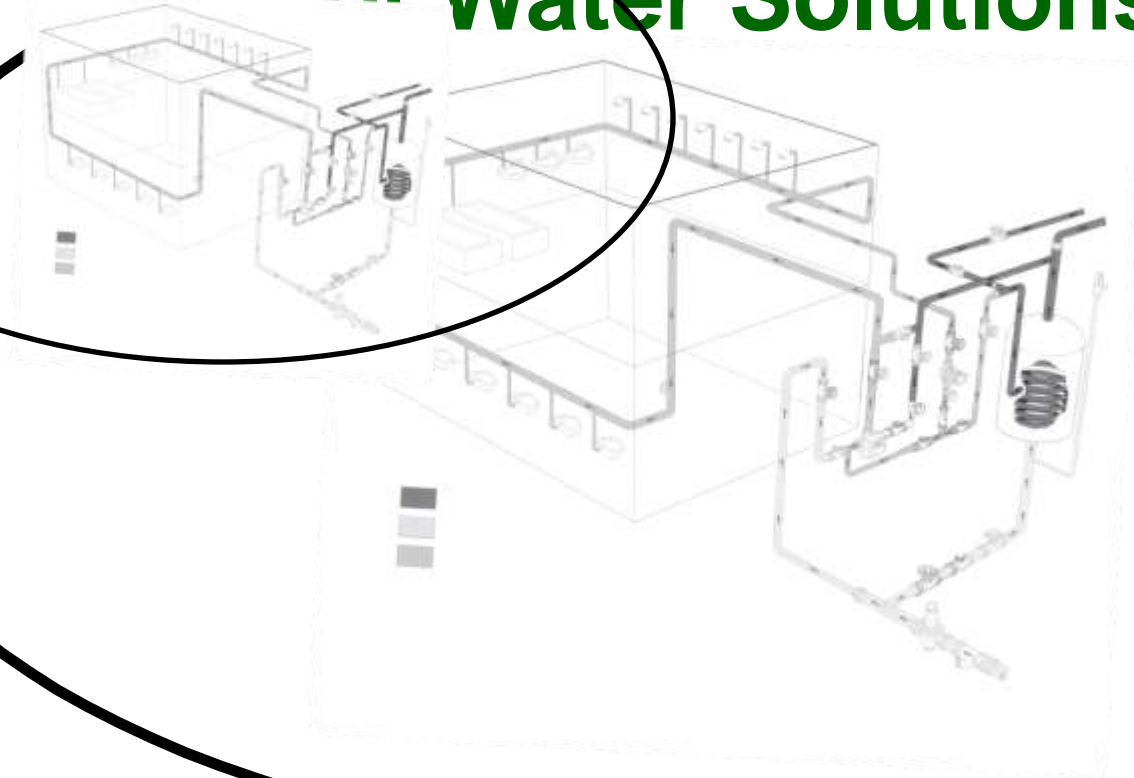

# HOT WATER SOLUTION FROM ARMSTRONG



Hose Stations & Washdown Equipment



Intelligent System Solutions® STEAM • AIR • HOT WATER

"Expect many enjoyable experiences!"

David M. Armstrong

# New Technologies from Armstrong TRAP VALVE STATIONS



# New Technologies from Armstrong

- Steam Eye<sup>®</sup>
  - **Wireless Steam Trap Monitoring**

Steam Eye<sup>®</sup> is a wireless steam trap monitoring system that detects a failed open or a failed closed steam trap; instantly alerting of failure.

  - Reduce Maintenance Costs
  - Increase Energy Savings
  - Combat Shrinking Budgets



# New Technologies from Armstrong

- Steam and Condensate Solutions

- **Double Duty™**

With the Double Duty steam Trap and Pump Combo, condensate is allowed to drain from the heat exchanger under all operating conditions, eliminating the stall problem and optimizing system efficiency.

The Armstrong Double Duty Series Steam Trap and Pump Combinations are:

- Low Maintenance
- Low-Profile
- Versatile



Double Duty™ 6



Double Duty™ 4

# New Technologies from Armstrong

- Hot Water Solutions
  - **The Brain<sup>®</sup> DRV80**  
Worlds first Digital Recirculating Valve
    - +/- 2°F accuracy
    - 0-34 m<sup>3</sup>/hr single valve capacity
    - BAS, LAN, wireless communication





## Message from Mr. David Armstrong



Intelligent System Solutions® STEAM • AIR • HOT WATER

"Expect many **enjoyable experiences!**"

David M. Armstrong



Intelligent System Solutions® STEAM • AIR • HOT WATER

"Expect many enjoyable experiences!"

David M. Armstrong

Covered Area : 4800 Sq.m  
(Under Shade)



Intelligent System Solutions® STEAM • AIR • HOT WATER

"Expect many enjoyable experiences!"

David M. Armstrong

# “Knowledge not shared is energy wasted.”



Intelligent System Solutions® STEAM • AIR • HOT WATER

“Expect many enjoyable experiences!”

David M. Armstrong