

ENERGY AUDIT
In
POWER SECTOR
Case Study
JINDAL POWER Ltd.
Tamnar, Raigarh (C.G)

BY

MCJ ENERGY ENGINEERS (P) LTD.

244, CHOUHAN ESTATE, G.E. ROAD, SUPELA, BHILAI (CG)

Mob: 9893008136, Email: mc_jain@yahoo.com

EXECUTIVE SUMMARY

- 1. Unit** : **M/s Jindal Power Limited**
: **Tamnar,Raigarh-496107,(C.G)**
- 2. Main Product** : **Electricity**
- 3. Total Electricity Generation** : **802.80 million kWh**
(Jan09-Dec09)
- 4. Electrical Energy Consumption** : **66.62 million kWh (8.30%)**
(Jan09-Dec09)
(By Auxiliary Equipment)
- 5. Annual Coal** : **5.24 million MT**
Consumption (Jan09-Dec09)
- 6. Estimated Annual** : **13.97 million kWh,**
Savings in Energy cost **Rs.41.92 million**

Contd....

8. Estimated Annual Savings in Coal cost	:	38488.29 MT, Rs.28.87 million
9. Expenditure to be incurred Towards Implementation of Recommendations	:	Rs.170.28 million
10. Additional annual Operating & Maintenance cost through Implementation of recommendations	:	Nil
11. Net Annual Savings	:	Rs.70.79 million

- 12. Simple Payback Period** : **2.4 Year or 29 Month**
- a. Low Cost Recommendation** : **6 Months**
 - b. Medium Cost Recommendation** : **2.6 Year or 31 months**
 - c. High Cost Recommendation** : **3 Yr. or 38 months.**

- 13. Average Percentage Savings**
- a. In annual Aux. Consumption** : **2.10%**
 - b. In annual Coal Consumption** : **0.73%**

- 14. Reduction in Aux. Consumption** : **0.18%**

INTRODUCTION

- ✚ Installed Capacity** : **4 X 250 MW**

- ✚ Principle Elements** :
 - a. Coal handling plant**
 - b. Boiler**
 - c. Turbo - alternator**
 - d. Ash handling**
 - e. Condenser Cooling**
 - f. Compressed Air system**
 - g. Lighting etc.**

- ✚ Process Used** : **Electrical energy & thermal energy**

PROCESS DESCRIPTION

A. Schematic Diagram of Power Plant

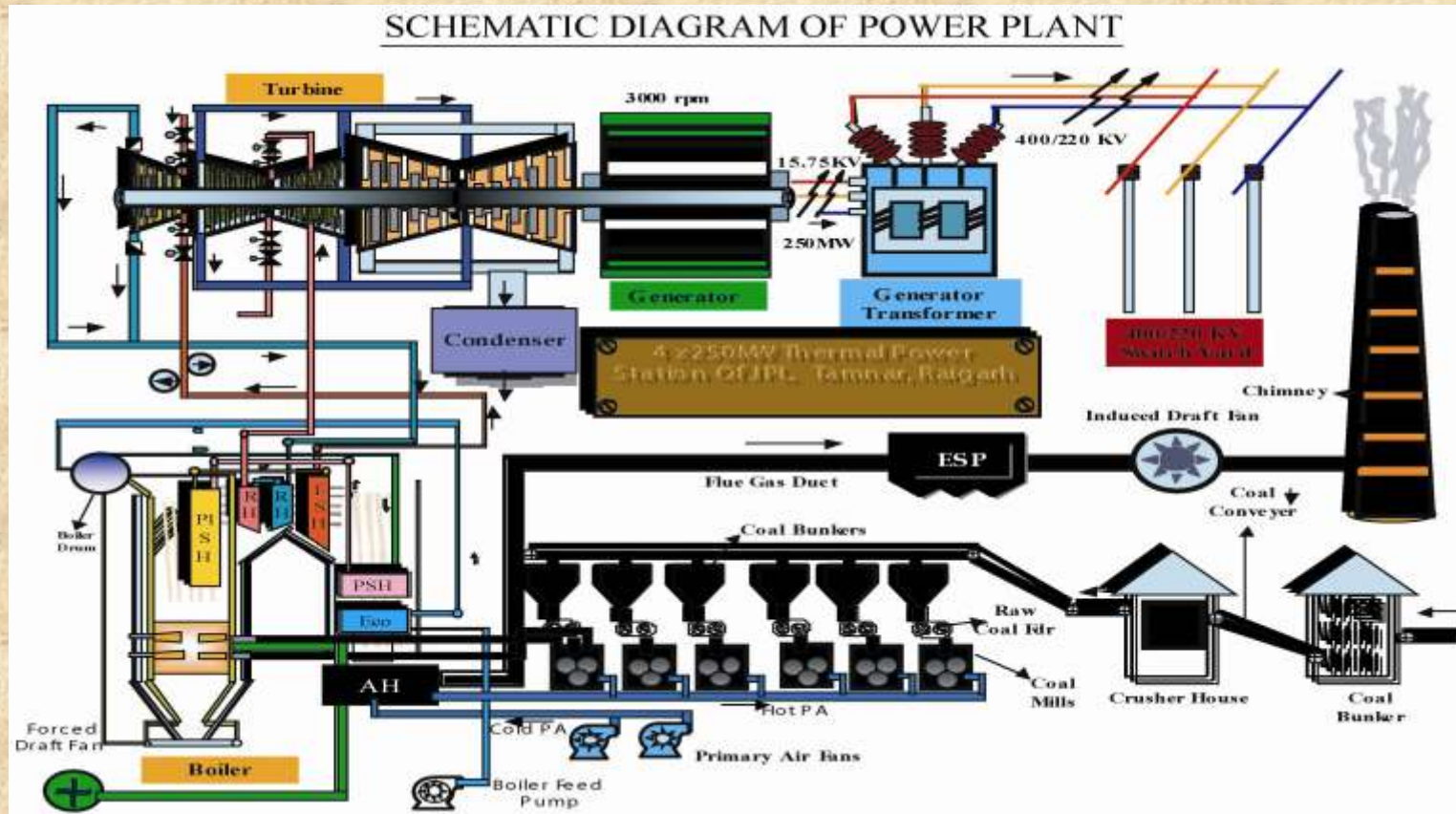

B. Energy & Mass Balance

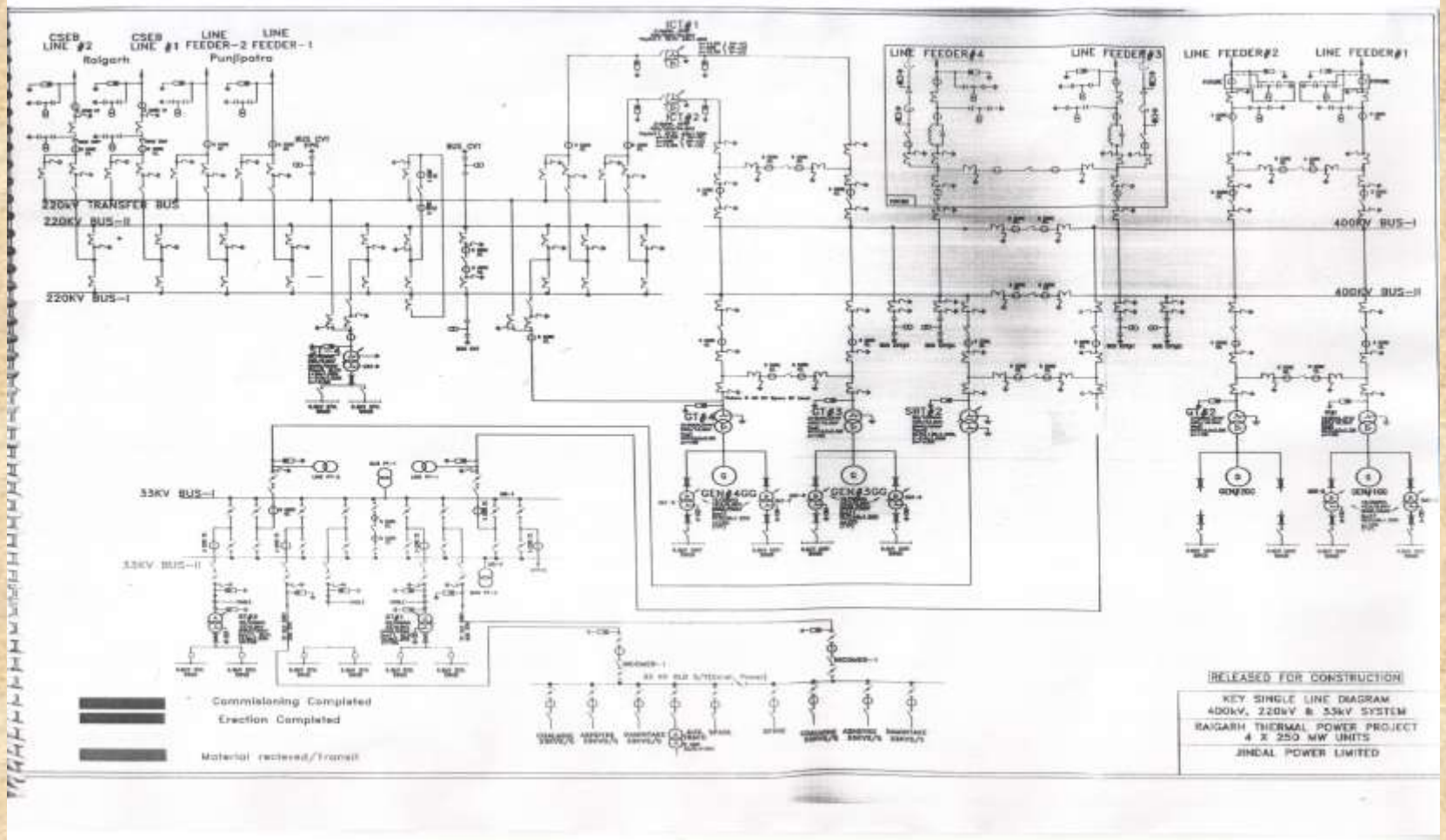

C. AUXILIARY STEAM SYSTEM DIAGRAM

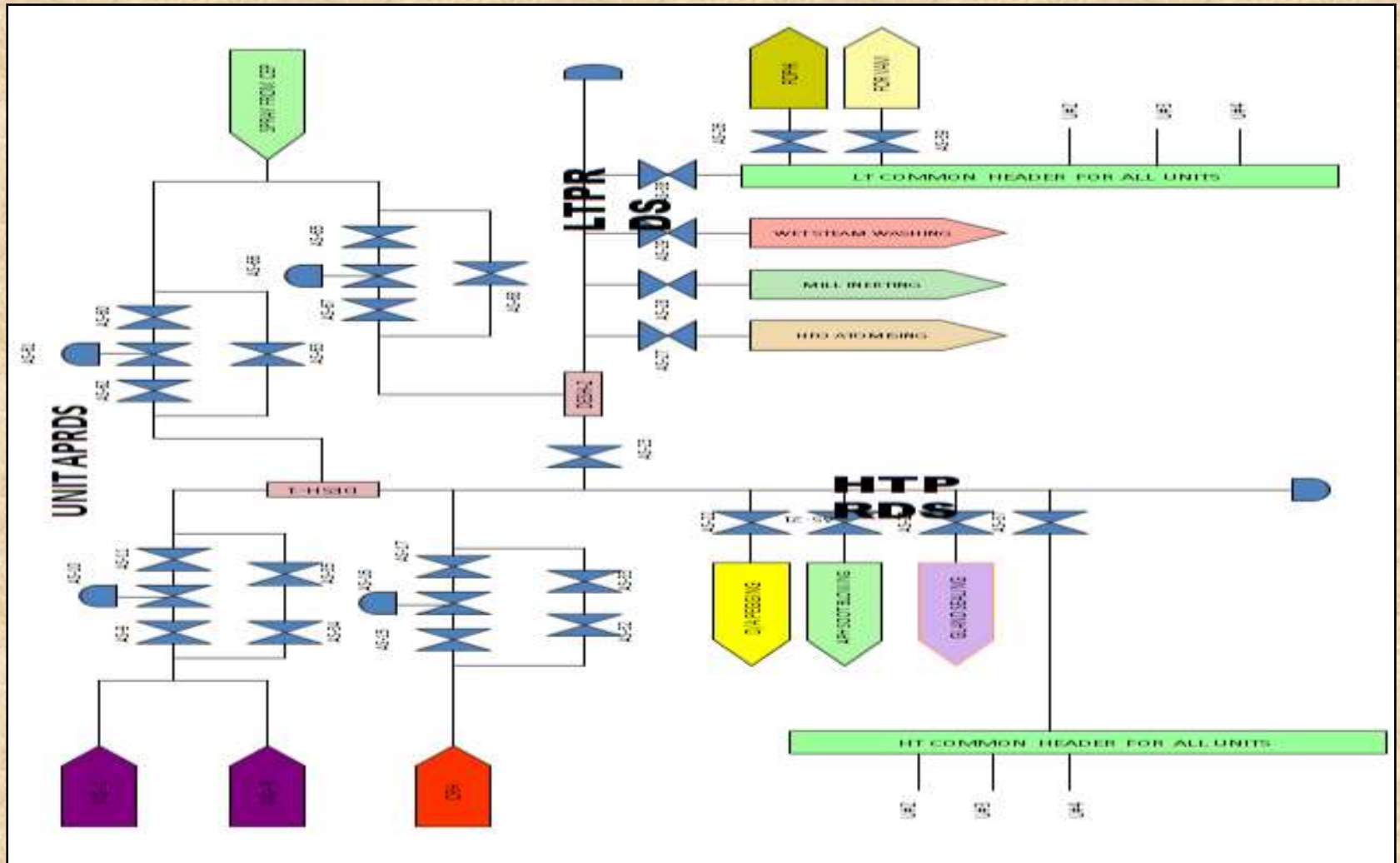

AUXILIARY SYSTEMS

+ Fly ash collection

+ Bottom ash collection and disposal

+ Boiler make-up water treatment plant and storage

+ Steam turbine-driven electric generator

+ Condenser

DIAGRAM OF A TYPICAL WATER-COOLED SURFACE CONDENSER.

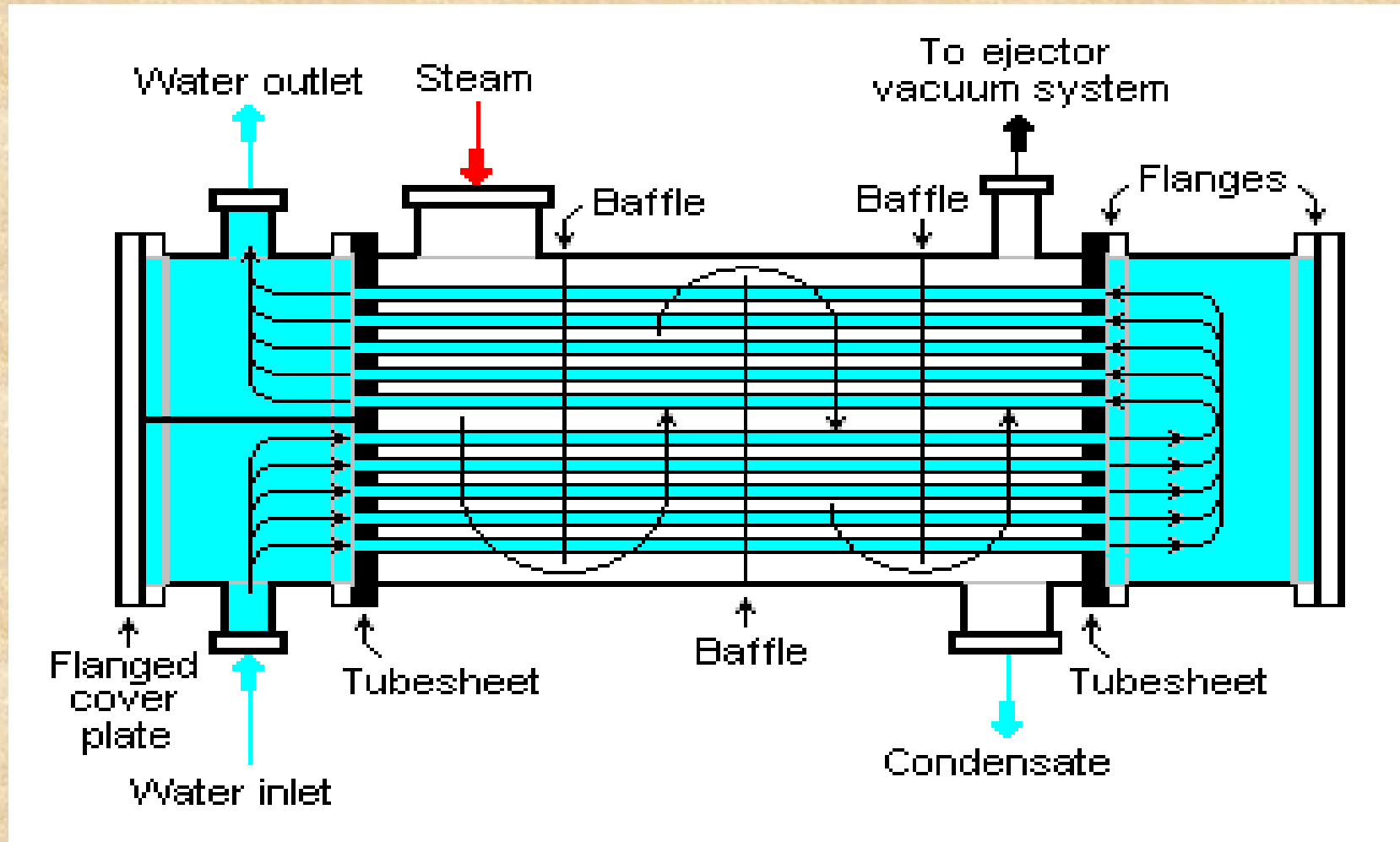

✚ Feedwater heater

✚ Deaerator

Diagram of boiler feed water deaerator

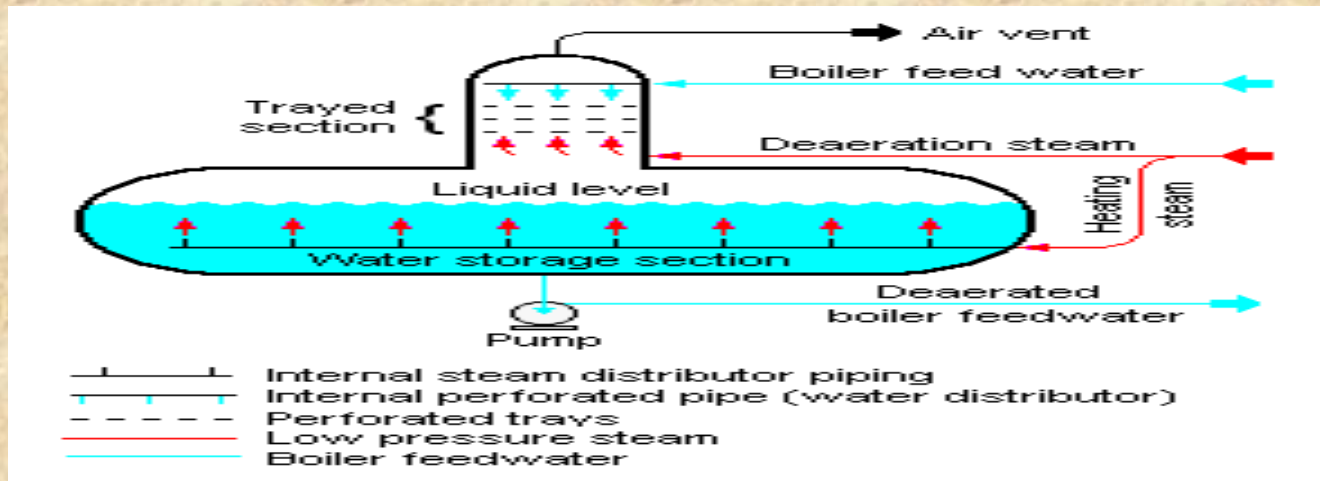

✚ Oil system

✚ Generator high voltage system (16.5 kV)

✚ Monitoring and alarm system

✚ Emergency lighting and communication

ENERGY CONSERVATION OPTIONS & RECOMMENDATIONS

A. NO COST

✚ Disconnecting Booster Pump of Ash Slurry System

S.No	Description	Rated			Measured Actual			Percentage loading (%)
		V (volts)	KW	Efficiency (%)	I (amp)	P.F.	Input Power (KW)	
1	Ash Slurry Pump Motor, with booster pump connected	440	150.00	92.00%	207.00	0.72	116.00	71.16%
2	Ash Slurry Pump Motor, with booster pump not connected	440	150.00	92.00%	127.60	0.64	63.00	38.64%
DIFFERENCE							53.00	

Annual savings : 0.84 million kWh/ Annum

Annual cost saving : Rs. 2.52 million

Pay-back period : Immediate

- Repairing the Damaged Insulation

CALCULATION OF SURFACE HEAT LOSS						
Sl. No.	LOCATION	TEMP T_f °C	Length (mtr)	Diameter (mtr)	Area m^2	Surface Heat Loss Kcal/hr
UNIT-1						
1	HP Heater Vent	50	12.00	0.30	11.30	2486.88
2	HP cylinder	79	2.00	0.30	1.88	1149.33
4	Insulation Valve of Extraction-2 To H.P Heater	96	0.70	0.50	1.10	964.70
5	Gland Sealing System Valve (MAW-10)	78	1.00	0.75	2.36	1401.70
6	HP Bypass valve	80	0.75	0.75	1.77	1103.91
UNIT-2						
1	HPH-5 Man Hole Cover	100		0.50	0.20	185.46
2	HP Cylinder	71	2.00	0.30	1.88	930.79
3	IP Casing	79	2.00	0.30	1.88	1149.33
UNIT-3						
1	HRH Line	50	3.00	0.30	2.83	621.72
UNIT-4						
1	HPH-5 Man Hole Cover	100		0.50	0.20	185.46
TOTAL SURFACE HEAT LOSS IN kCal/Hr.						10179.28

Note:

Annual saving of the coal : 23.48505 Tonnes/ Annum

Total Cost saving : Rs. 17,614.00

Pay-back period : Immediate

B. LOW COST

✚ HPSV lamps of 150 watts can be replaced by 50 LVD lamps of 50 watts

TYPE OF LAMP	LAMP WATTGE	LIFE OF LAMP (HOURS)	DEPRECIATION	LIGHTING EFFICIENCY	CHOKE RATING
HPSV (existing)	150	15000-20000	30% @ 2000 hrs	90 Plm/W	20
LVD (Proposed)	50	100000	5% @ 2000 hrs	150 Plm/W	Nil

Estimated energy savings : 155928 kWh / Annum

Annual cost savings : Rs. 467,784

Pay back period : 3.8 years or 45 months

✚ Insulating the clamps of the heated pipelines

CLAMPS OF HEATED PIPELINES DETAILS TABLE

Sl. NO:	PIPE LINE	TEMP °C	TYPE OF CLAMP IN EACH UNIT			TOTAL NO. OF FLANGES IN EACH UNIT
			RISER	TUNION	H.P.	
1	Aux. Steam Line	280	0.00	0.00	62	62.00
2	Aux. Steam To Fuel Oil	280	0.00	0.00	39	39.00
3	Boiler Feed Discharge Line	200	6.00	0.00	58	64.00
4	Boiler Feed recirculating	160	3.00	0.00	28	31.00
5	Cold Reheat System	320	10.00	0.00	31	41.00
6	Extention-1	260	0.00	0.00	7	7.00
7	Extention-2	260	0.00	0.00	6	6.00
8	Extention-3	260	0.00	0.00	6	6.00
9	Extention-5	300	0.00	0.00	1	1.00
10	Extention-6	300	0.00	0.00	6	6.00
11	Hot Reheat	540	10.00	10.00	38	58.00
12	High Pressure By Pass Line	540	2.00	0.00	11	13.00
13	LP Bypass	540	2.00	2.00	15	19.00
14	Aux. Steam LT Header	260	0.00	0.00	87	87.00
15	Main Steam Line	540	10.00	10.00	41	61.00
16	Pre reducing system	320	0.00	0.00	13	13.00
17	Reheater & Super heater spray	250	0.00	0.00	10	10.00
TOTAL CLAMPS IN EACH UNIT						524.00
TOTAL NO. OF CLAMPS FOR ALL FOUR UNITS						2096.00

Annual saving of the coal : 21640.8 Tonnes/ Annum

Total cost savings : Rs. 16,230,600.00

Pay-back period : 0.4 years or 5 months

C. MEDIUM COST

- ✦ Installation of new screw compressor to replace the partially loaded compressor we recommend installation of 2 screw compressors of 60 Cum/ min. capacity. One working and another stand by.

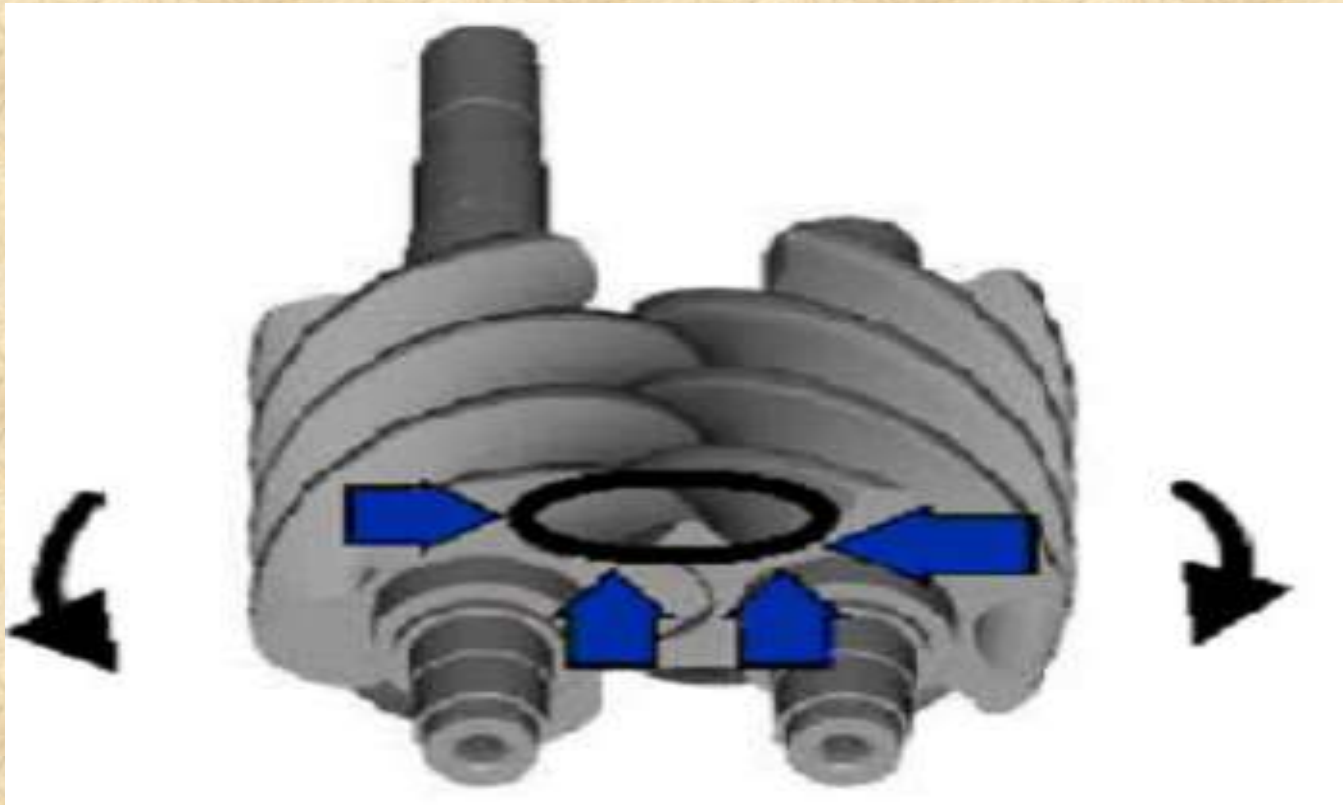

✚ During our study, we observed that the compressor running at partial load was loaded for approximately 20 min. or loaded for 8 hours/ day and unloaded for 16 Hours.

✚ During our study, we observed that the compressor running at full load was drawing input power of 808 KW.

✚ Energy consumption for the second compressor during loaded condition = $808 \times 8 = 6464 \text{ kWh}$

✚ Assuming 30% energy consumption during unloaded condition = $808 \times 16 \times 0.3 = 3878.4 \text{ kWh}$

✚ Total energy consumption in the second compressor per day = Energy Consumption in loaded condition + Energy Consumption in un-loaded condition = $6464 + 3878.4$, Or $= 10342.4 \text{ kWh}$

✚ After installation of a screw compressor of 60 Cum/ min. capacity it would be required to run for approximately. 17 hours per day $[(127 \times 8)/60]$, with automatic on-off control.

✚ Power consumption of the screw compressor would be approximately = 380 kWh

✚ 1. Therefore power consumption/ day would be = $380 \times 17 = 6460$ kWh/ Day

✚ Annual savings : 1281192 kWh/ Annum

✚ Annual cost saving : Rs. 3843576.00

✚ Pay-back period : 2 years 7 months

D. HIGH COST



Flash Steam Generation System

It was observed during our study, that the steam is used to the run the following auxiliary services -:

- 1. Deaeration, of the feed water.**
- 2. Gland Sealing**
- 3. Soot Blowing**
- 4. D/A Pegging**
- 5. Air Conditioning (VAM System)**
- 6. HFO Atomisation**
- 7. Mill Inerting**
- 8. FOPH**
- 9. Wet Steam Washing**

+ Application of VFD

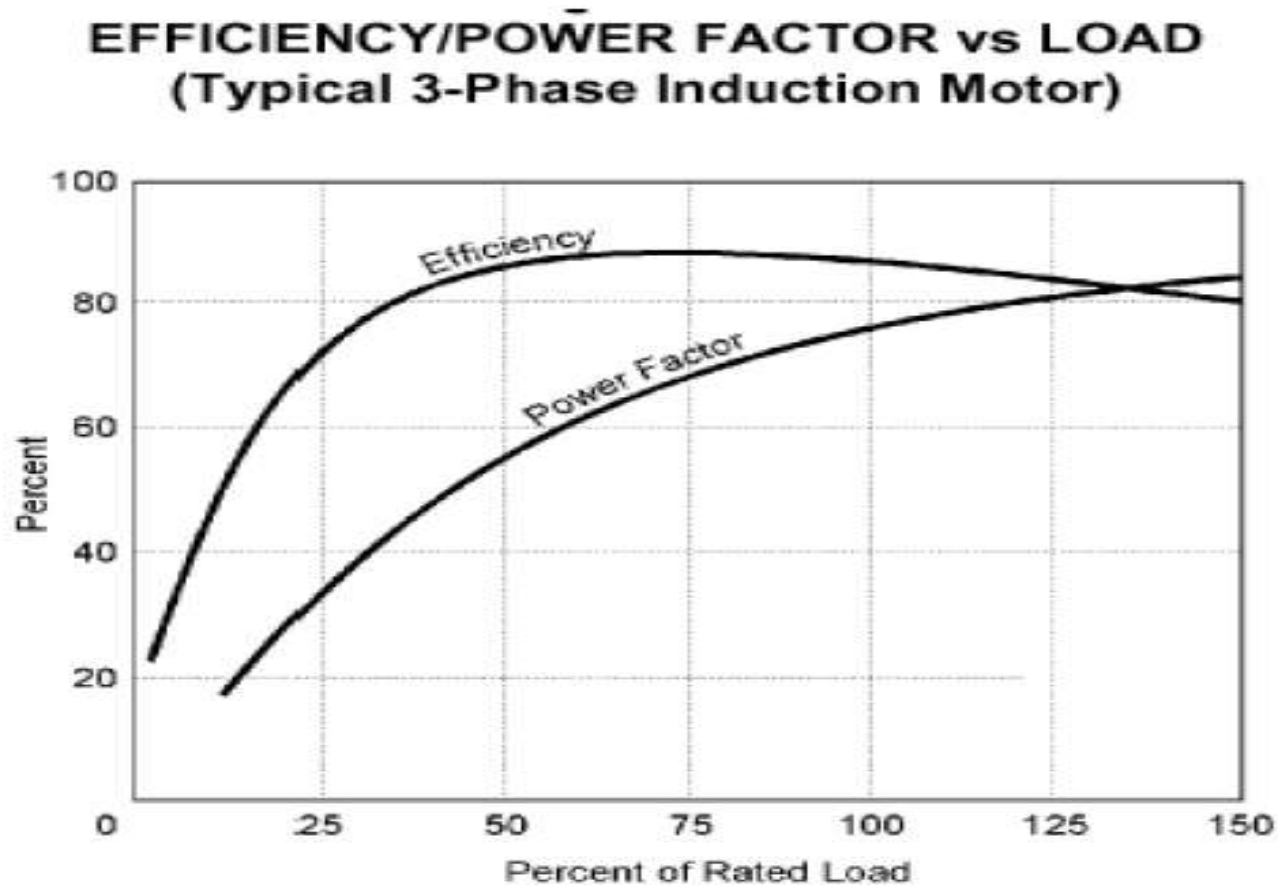

Flash Steam Generation System

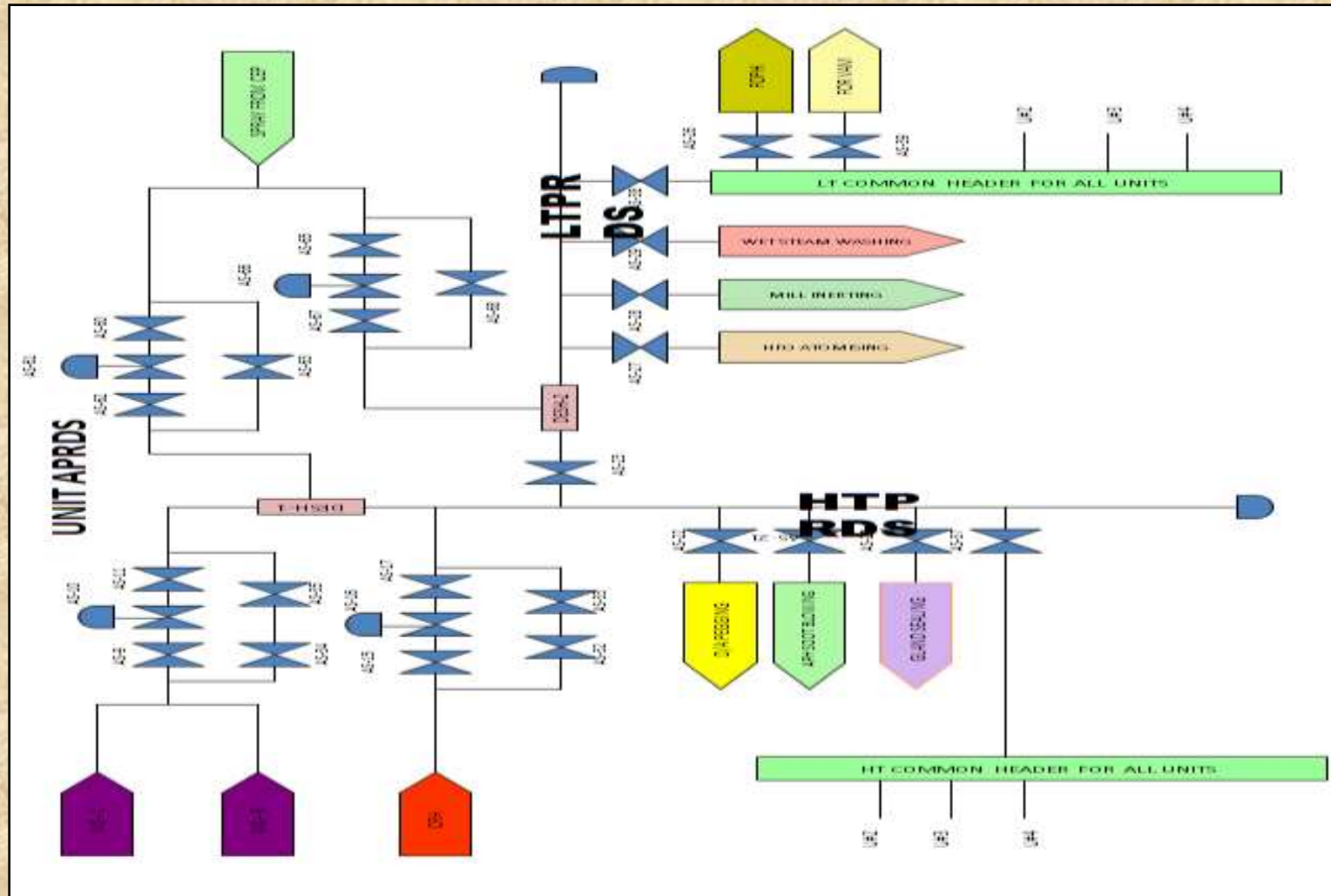

Flash Steam Generation System

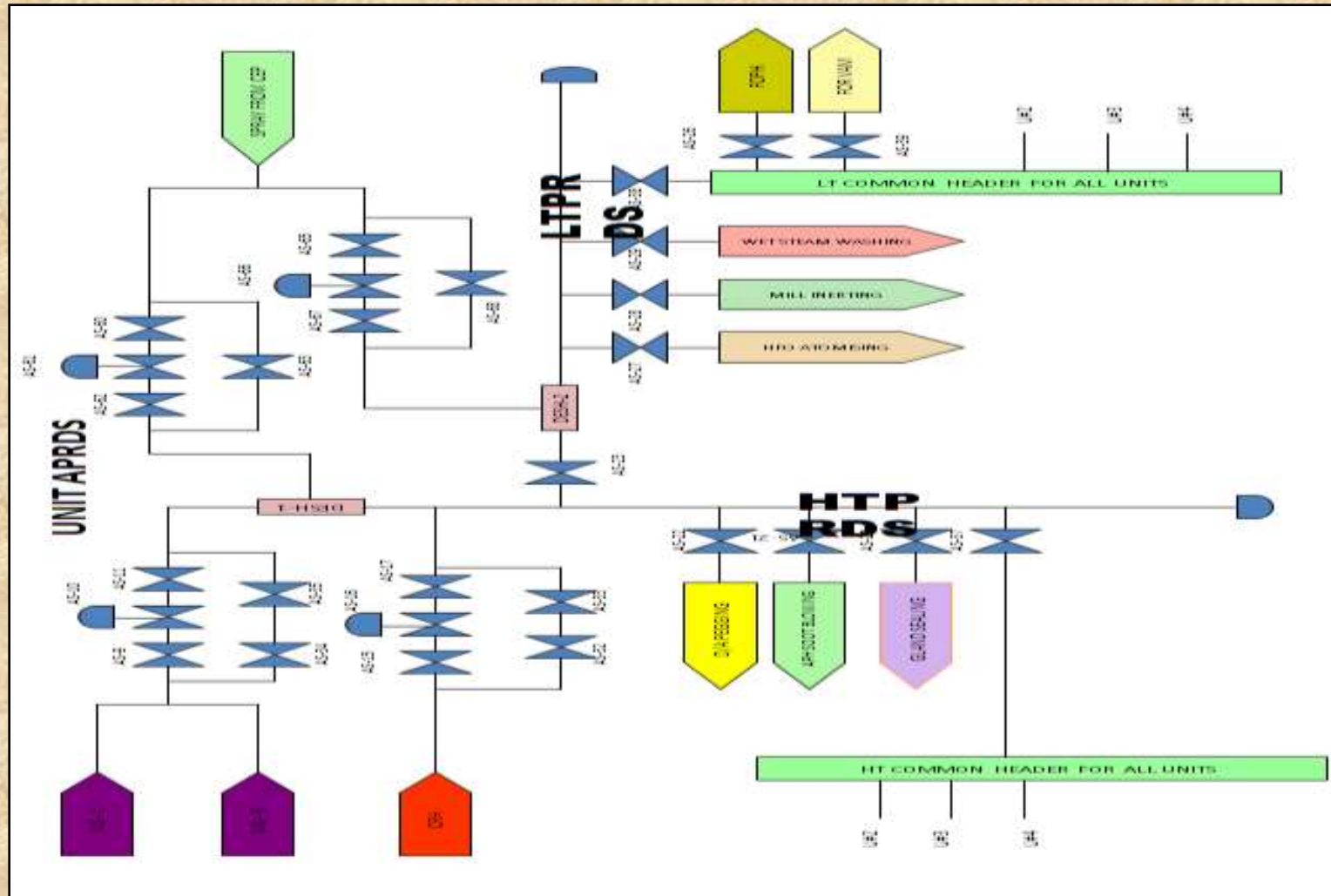

calculations is presented in Annexure 6.1 -:

Sl. No.	Location of Motor	Percentage Loading and Power Factor	Efficiency as per the Curve	Efficiency after change over	Annual Saving (kWh), considering 7920, operational hours
1.	PA FAN-1A# 1LMRO7A, 1100 kW	42 % P.F. – 0.82	84.00 %	95 %	726343.2
2.	PA FAN-1B# 1LMRO7B, 1100 kW	40 % P.F. – 0.80	83.00 %	95%	750340.8
3.	PA FAN-2A# 2LMRO7A, 1100 kW	39 % P.F. – 0.81	82.00 %	95 %	783604.8
4.	PA FAN-2B# 2LMRO7B, 1100 kW	39 % P.F. – 0.80	82.00%	95%	781387.2
5.	PA FAN-3A# 3LMRO7A, 1100 kW	46 % P.F. – 0.83	86.00%	95%	607780.8
6.	PA FAN-3B# 3LMRO7B, 1100 kW	43 % P.F. – 0.83	85.00%	95%	674467.2
7.	PA FAN-4A# 4LMRO7A, 1100 kW	40 % P.F. – 0.82	83.00%	95%	743292.0
8.	PA FAN-4B# 4LMRO7B, 1100 kW	40 % P.F. – 0.82	83.00%	95%	748281.6
9.	FD FAN-1A # 1LMRO6A, 675 kW	28 % P.F. – 0.60	75.00%	95%	333511.2
10.	FD FAN-1B # 1LMRO6B, 675 kW	30 % P.F. – 0.62	76.00%	95%	348480.0
11.	FD FAN-2A.# 2LMRO6A, 675 kW	35 % P.F. – 0.65	80.00 %	95%	312602.4
12.	FD FAN-2B # 2LMRO6B, 675 kW	24 % P.F. – 0.64	69.00 %	95%	375012.0
13.	FD FAN-3A # 3LMRO6A, 675 kW	33 % P.F. – 0.65	77.00%	95%	360122.4
14.	FD FAN-3B # 3LMRO6B, 675 kW	35 % P.F. – 0.67	80.00%	95%	312602.4
15.	FD FAN-4A # 4LMRO6A, 675 kW	33 % P.F. – 0.67	77.00%	95%	360122.4
16.	FD FAN-4B # 4LMRO6B, 675 kW	28% P.F. – 0.60	75.00%	95%	333511.2
TOTAL					8551461.6

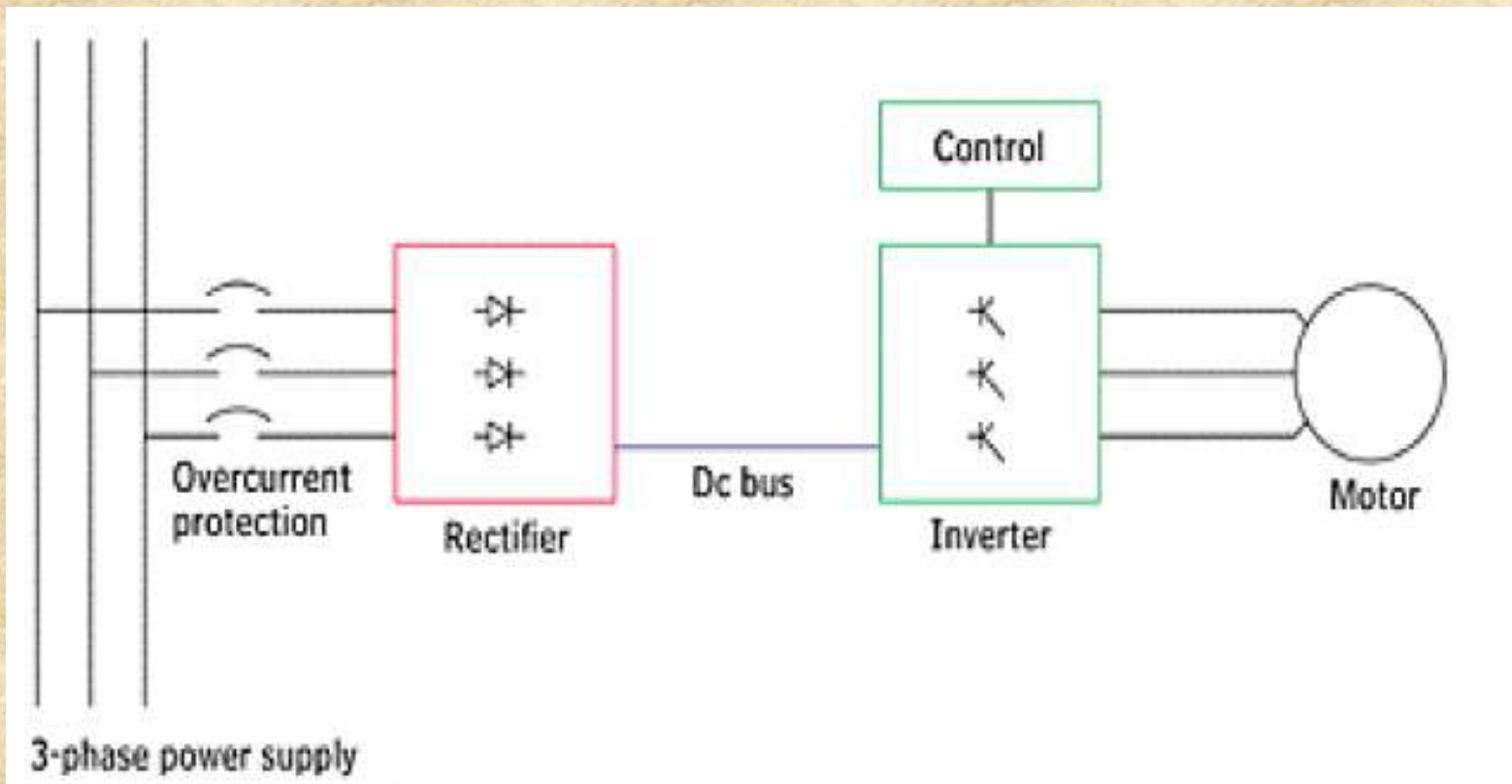

Annual cost savings	:	Rs. 25,654,384.8
Investment Cost	:	Rs. 112,000,000.00
Pay back period	:	4.37 Years or 4 year

CONCLUSION

The energy consumption is mainly thermal energy, from burning coal. The electric energy is being used to run the auxiliary facilities, mainly in the motors of various utilities.

We have identified & recommended measures to increase the energy efficiency and cut down the cost of energy as well as production.

We found, it possible to save the electricity of value Rs.419.22 Lacs per annum and coal of value Rs. 288.66 Lacs

The cost of implementing our suggestions for energy savings would be Rs. 1702.8 Lacs, which would be average simple pay back of 2 Years and 5 Months.

The efforts of the, Operations Department, Electrical Department, and especially the Efficiency Department and other staff should be appreciated for their co-operation.



Thank

You