Yokogawa India Limited

WELCOMES ALL

*“ALL INDIA ENERGY EFFICIENCY CAPACITY
BUILDING PROGRAM”*

“Test & Measuring Instruments For Energy Conservation”

Global Presence

Operating in 29 countries
Number of affiliated companies outside Japan : 70

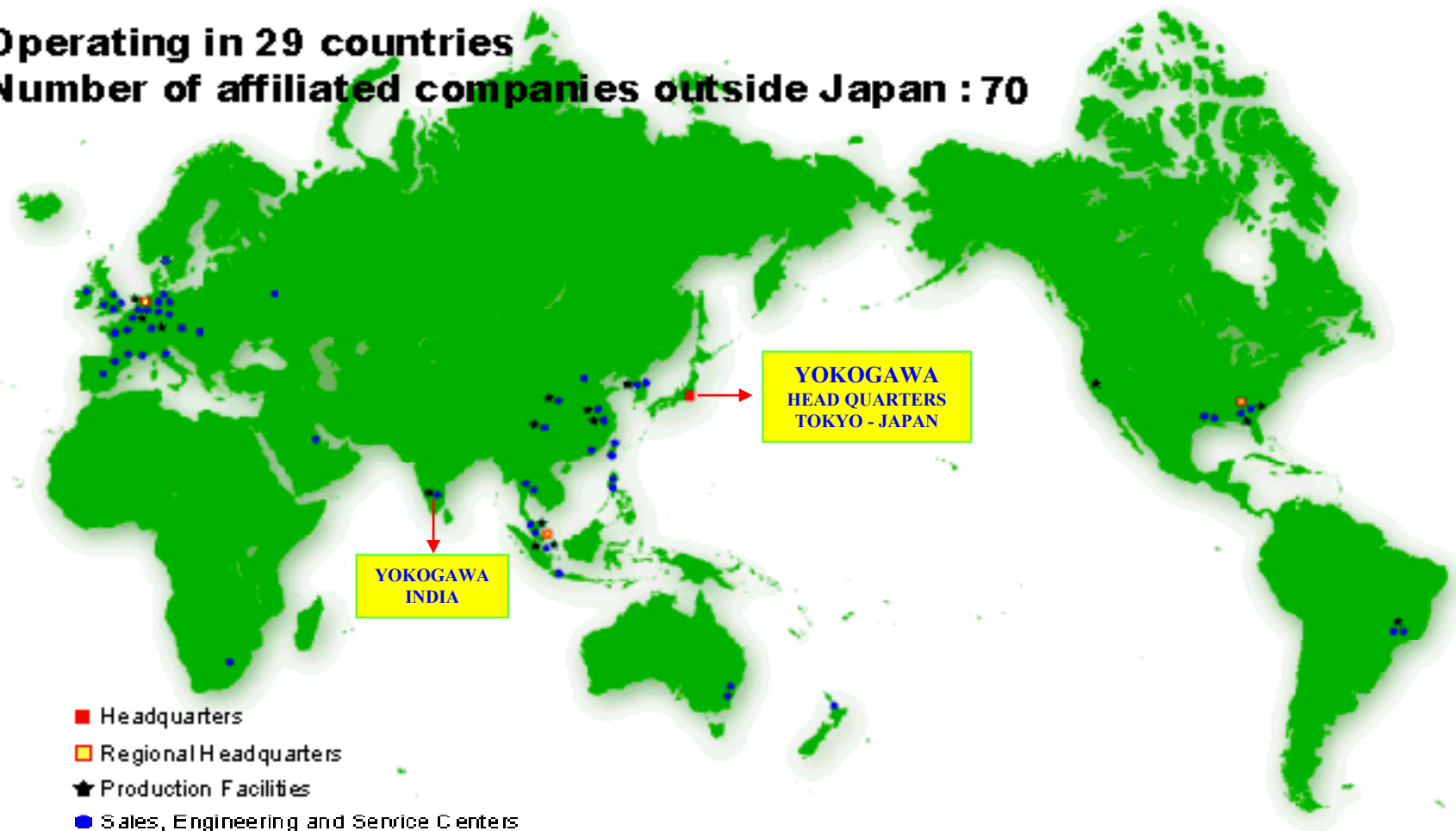



YOKOGAWA

PIONEERS IN PROCESS



BEST IN TEST SINCE 1915

PRESENTS

Test & Measuring Instruments for Energy Conservation

ACCURATE

- Digital Thermometer (contact type)
- Digital Thermometer (Non-contact)
- Manometer
- Digital Ultrasonic Flow Meter
- Digital Anemometer
- Clamp on Tester
- 3ph Digital Power Meter
- Digital Multimeter
- Digital Differential Pressure Manometer
- Digital Lux Meter
- Digital Tachometer

Test & Measuring Instruments - 1



**Digital
Oscilloscopes**



Power Meters



**Signal
Generators**

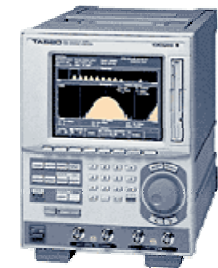

**Time Interval
Analyzers**



**Pressure
Standards**



**Digital Multimeter
Bench top**



Compact Calibrator



**PC-Based
Measuring Inst.**

Test & Measuring Instruments - 2



Digital Multimeters

Clamp Meters

Insulation Testers



Handy Calibrators



Clamp-on Power Meters



Test Bench

Clamp-On Power Meters

MCC



Thermometers

TX10

Free input from
TX Series

Date	Measured Time	Measured Value	Humidity
1997/7/15	15:09:52	75.1°C	
1997/7/15	15:09:53	78.2°C	
1997/7/15	15:09:55	81.3°C	
1997/7/15	15:09:57		
1997/7/15	15:09:59		

Free input from
TM Series

TM10
Thermistor Input

TM20
Thermocouple Input

MCC

Analog & Digital Lux Meter

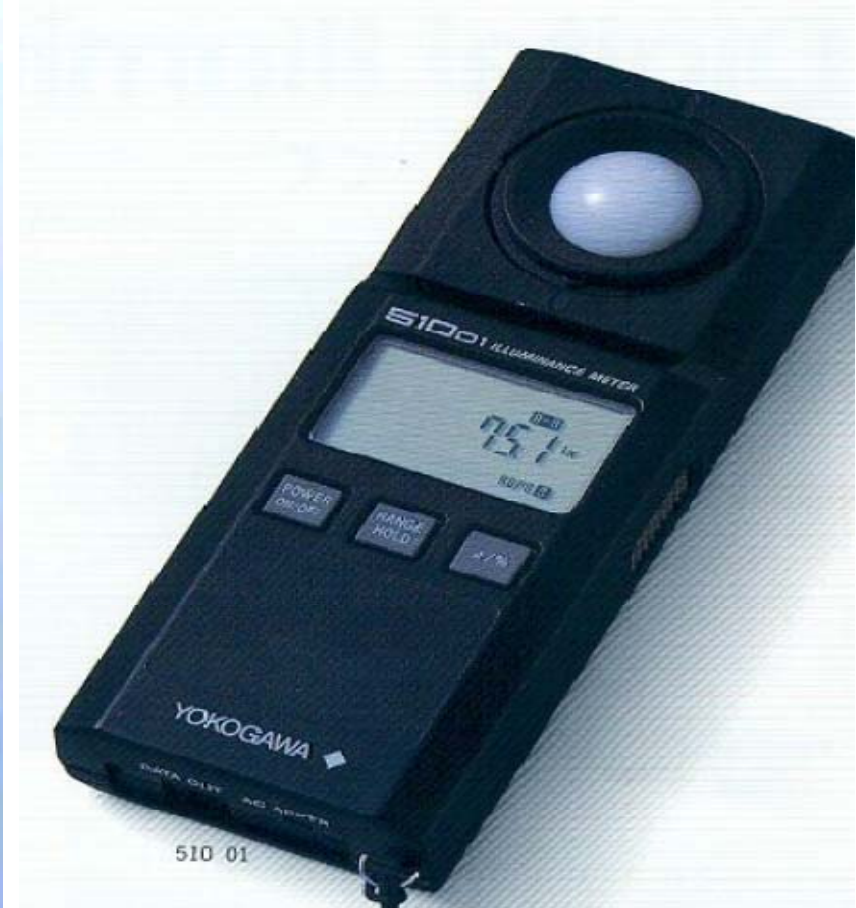

Energy Saving Tool (line freq)

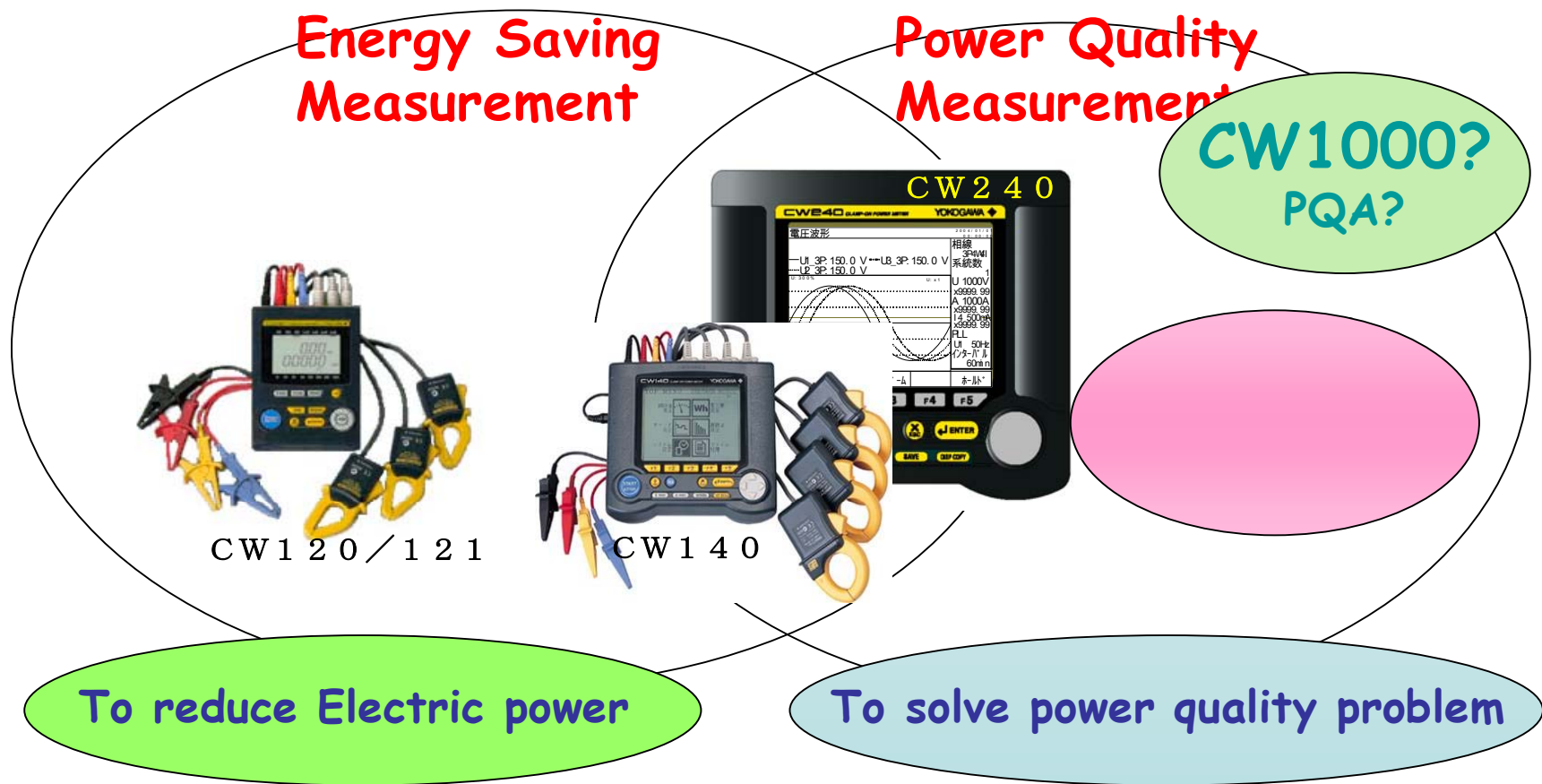

Characteristics 1

Electric Power Search & PQ Management

Instantaneous Value

Harmonics

Simultaneous measurement of All items and save all data

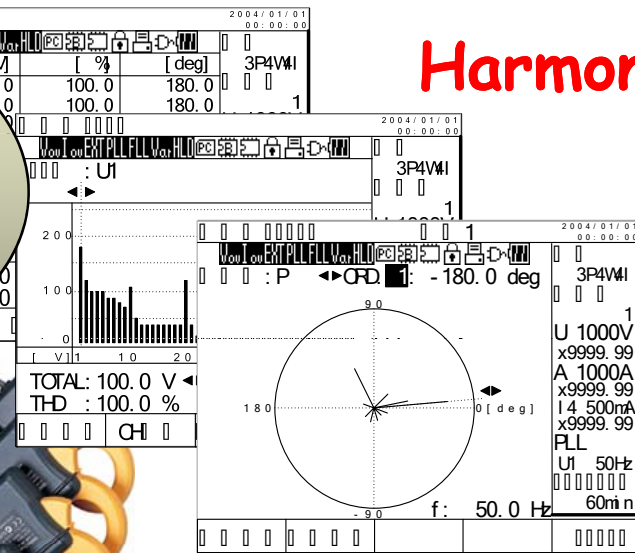
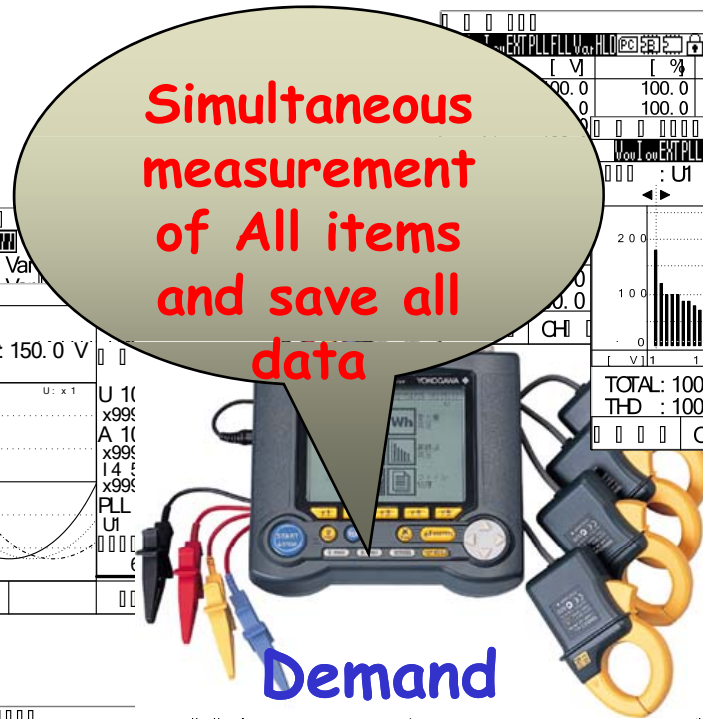
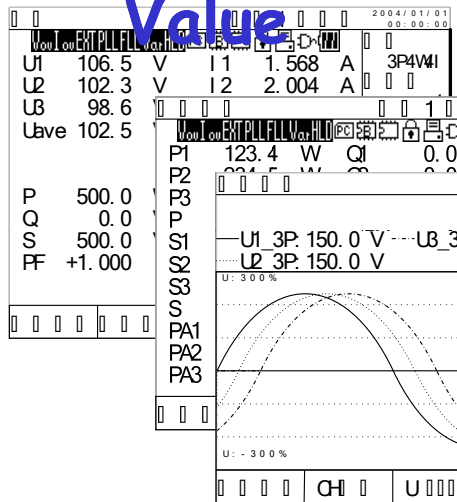

Electric Energy

Demand

Voltage Fluctuation

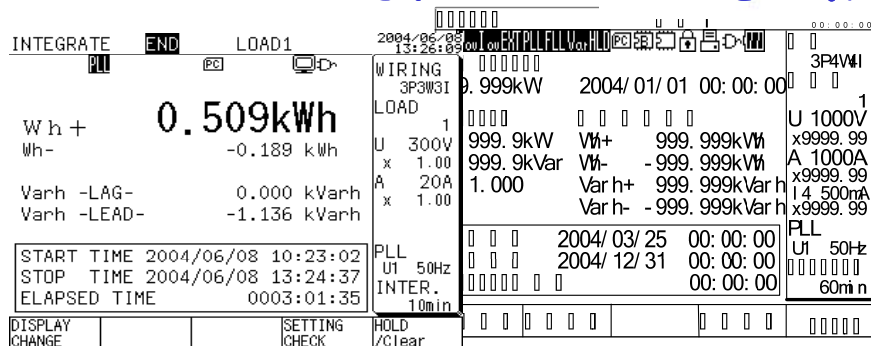

Date	Time	Item	CH	RMS	Period
01/01	12:34	56.555	Swe	1_1P	01:23:45.000
01/11	09:12	34.555	Dip	1_1P	00:12:34.567
02/01	09:55	55.000	Int	1_3P	00:00:15.000
03/01	08:30	56.123	Swe	1_1P	00:00:00.000
04/01	11:11	11.111	Dip	1_1P	00:01:11.111
01/01	00:00	00.000	Swe	1_3P	00:00:00.000
01/01	00:00	00.000	Int	1_1P	00:00:00.000
01/01	00:00	00.000	Swe	1_3P	00:00:00.000
01/01	00:00	00.000	Swe	1_3P	00:00:00.000
01/01	00:00	00.000	Swe	1_1P	00:00:00.000
01/01	00:00	00.000	Swe	1_1P	00:00:00.000
01/01	00:00	00.000	Swe	1_1P	00:00:00.000
01/01	00:00	00.000	Swe	1_1P	00:00:00.000
01/01	00:00	00.000	Swe	1_3P	00:00:00.000

Electric Power Management 1

Instantaneous Value Measurement 1

45~65Hz

-Display Instantaneous Value for each measurement item

Each Phase Voltage/Current/Electric Power/Power Factor/Frequency /Phase Angle/Reactive Power/Apparent Power

-**Mean/Min/Max** display for each me

← LIST END LOAD1 INST. 2004/06/08 13:33:43

U1	211.9 V	I1	9.39 A
U2	211.0 V	I2	7.83 A
U3	214.0 V	I3	13.14 A
Uave	212.3 V	Iave	10.12 A
P	0.08 kW	PA	-88.7 °
Q	-0.37 kVar	f	50.00 Hz
S	3.74 kVA	DC1	0.0 mV
PF	-0.054	DC2	0.0 mV

WIRING 3P3W3I
 LOAD 1
 U 300V x 1.00
 A 20A x 1.00
 PLL U1 50Hz INTER. 10min

DISPLAY CHANGE	ITEM CHANGE	SETTING CHECK	HOLD /Clear
----------------	-------------	---------------	-------------

Saving

c, 1/2/

POWER END LOAD1 INST. 2004/06/08 13:33:18

P1	0.60 kW	Q1	0.97 kVar
P2	0.82 kW	Q2	-0.46 kVar
P3	-1.34 kW	Q3	-0.88 kVar
P	0.08 kW	Q	-0.37 kVar
S1	1.14 kVA	PF1	0.523
S2	0.94 kVA	PF2	-0.870
S3	1.60 kVA	PF3	-0.834
S	3.68 kVA	PF	-0.063
PA1	58.5 °	PA	-88.9 °
PA2	-29.6 °		
PA3	-146.5 °		

WIRING 3P4W4I
 LOAD 1
 U 1000V x9999.99
 A 1000A x9999.99
 U 300V x 1.00
 A 20A x 1.00
 PLL U1 50Hz INTER. 10min

DISPLAY CHANGE	ITEM CHANGE	SETTING CHECK	HOLD /Clear
----------------	-------------	---------------	-------------

Electric Power Management 2

Instantaneous Value Measurement 2

Wave form display can be possible with short time interval

1 cycle (1 wave form) / 0.1/0.2/0.5 sec

-Measuring elements: Voltage, Current, Voltage & Current

-Max 20 times zoom for vertical axis (X1/3, X1/2, X 1 , X2, X5, X10, X20)

-Data saved by bin

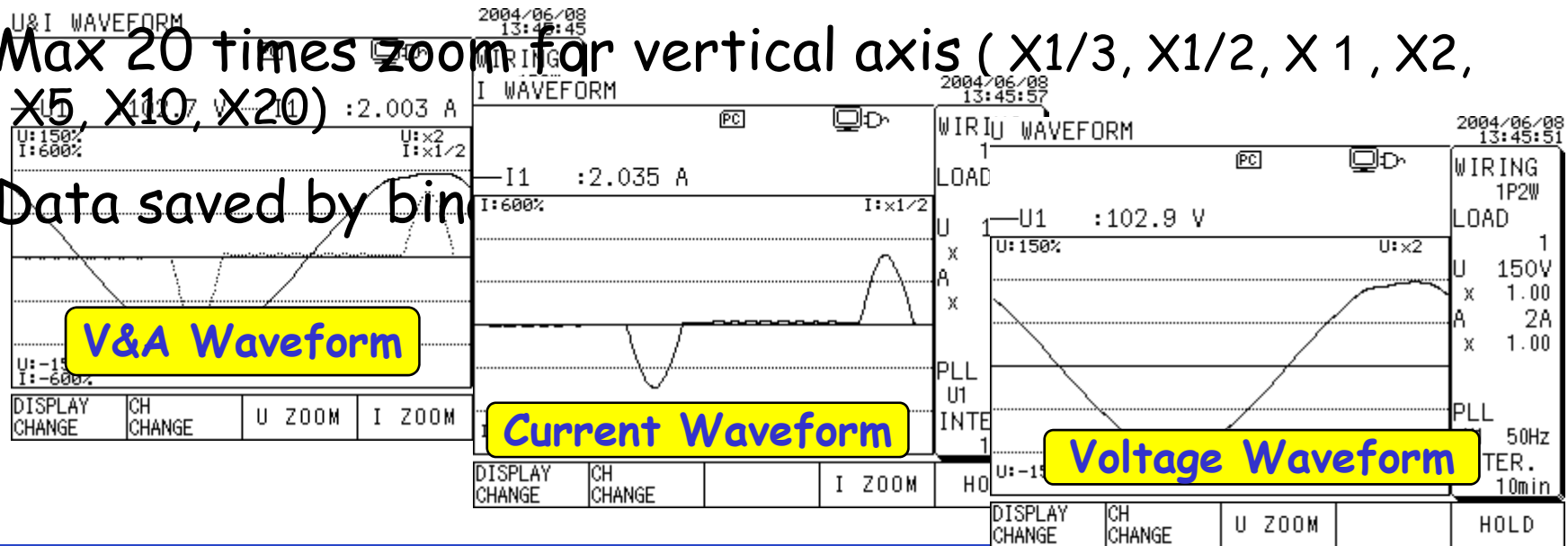

Electric Power Management 3

Electric Energy Measurement

- Data Acquisition Time: **1/2/5/10/15/30 sec.**
1/2/5/10/15/30/60 min.
- Measuring Elements: Active power energy, Regenerative electric power energy, Lag reactive energy, Lag, Lead energy reactive
- Measurement Range:

Active Power Energy: Consumption 0.00000mWh ~ 999999GWh

INTEGRATE	END	LOAD1	2004/06/08 13:28:09
PLL	PC		WIRING 3P3W3I LOAD 1
Wh +	0.509kWh		U 300V
Wh -	-0.189 kWh		x 1.00
Varh -LAG-	0.000 kVarh		A 20A
Varh -LEAD-	-1.136 kVarh		x 1.00
START TIME 2004/06/08 10:23:02			PLL
STOP TIME 2004/06/08 13:24:37			U1 50Hz
ELAPSED TIME 0003:01:35			INTER. 10min
DISPLAY CHANGE		SETTING CHECK	HOLD /Clear

Regenerative -0.00000mWh ~ -

Lag 0.00000mvarh ~

Lead -0.00000mvarh ~ -

Electric Power Management 4

Demand Measurement

-MAX Demand and Display its occurrence time

-Measuring Elements: 1) Active Power, Reactive Power (Dead Time),

Power Factor,

2) Active Power Energy (Consumption & Regenerative), Reactive Power Energy (Lead & Lag)

(Lead &

of time

3)

DEMAND		END	LOAD1	2004/06/08 13:26:02
MAXIMUM DEMAND		0.12 kW	2004/06/08 11:13:02	
DEMAND VALUE	INTER.ELEC.ENERGY			
P 0.11kW	Wh+ 0.000kWh			
Q 0.00kVar	Wh- 0.000kWh			
PF-0.063	Varh+ 0.000kVarh			
	Varh- 0.000kVarh			
START TIME	2004/06/08 10:23:02			
STOP TIME	2004/06/08 13:24:37			
DEMAND REST TIME	00:08:25			
DISPLAY CHANGE		SETTING CHECK	HOLD /Clear	

from the beginning and Occurrence

Electric Power Management 5

Harmonics Measurement

- Harmonics Analysis : 1 to 50th order
- Display Data : List/Bar Graph(Linear/Log)/Vector
- Measuring Elements : RMS Value/Content/Phase angle (Voltage for each order/Current/Electric Power)
- Total Value (Total value of Voltage, Current, Electric power and Power factor)



-Total relative harmonic current, THD-H or

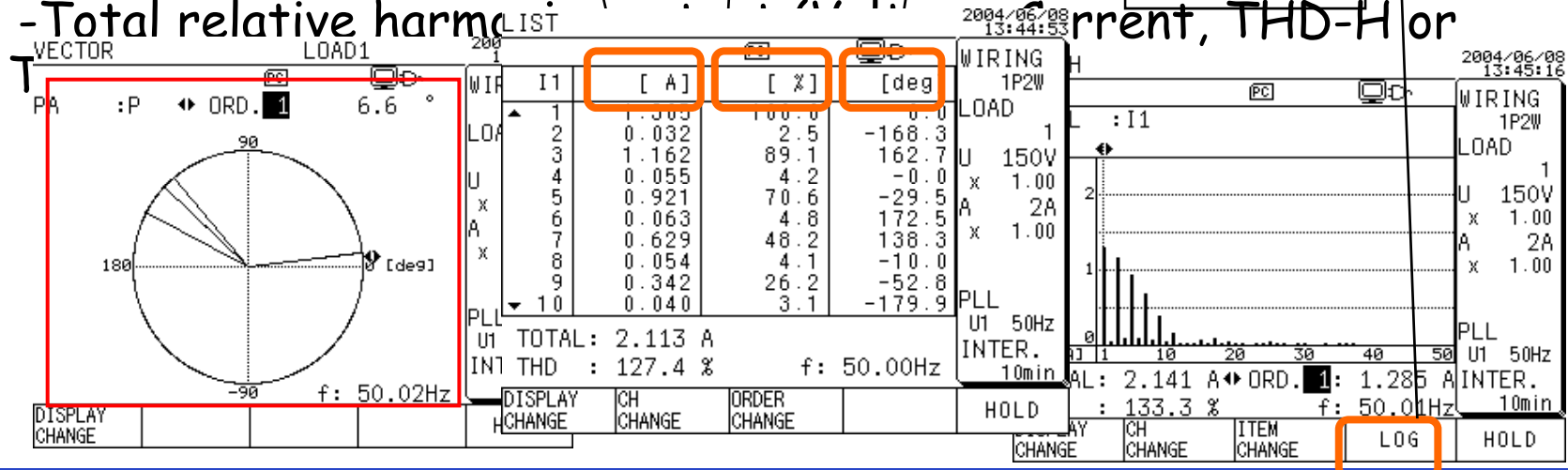

3 . -3. Power Quality Management



Voltage fluctuation

- Voltage Dip, Voltage Swell and detect instantaneous power failure
- Save data for Date of detection, Item, Channel, RMS and Detection period

***Set threshold for voltage, and record when the value is going out of the set threshold**

Item
 Swe : Swell
 Dip : Dip
 Inst. Power failure

Channel

0 : Occurrence
 End

RMS

2004/06/08
 13:48:22
 14/100

Date	Time	Item	CH	DI	RMS	Period
06/08	13:48:01.636	Dip	1	I	73.6 V	00:00:00.000
06/08	13:48:01.668	Int	1	I	0.5 V	00:00:00.000
06/08	13:48:02.369	Int	1	O	42.3 V	00:00:00.701
06/08	13:48:02.391	Dip	1	O	102.6 V	00:00:00.755
06/08	13:48:02.410	Swe	1	I	110.6 V	00:00:00.000
06/08	13:48:02.429	Swe	1	O	96.6 V	00:00:00.019
06/08	13:48:04.914	Dip	1	I	0.4 V	00:00:00.000
06/08	13:48:04.914	Int	1	I	0.4 V	00:00:00.000
06/08	13:48:05.075	Int	1	O	72.2 V	00:00:00.161
06/08	13:48:05.095	Dip	1	O	102.3 V	00:00:00.181
06/08	13:48:08.683	Dip	1	I	86.1 V	00:00:00.000
06/08	13:48:08.716	Int	1	I	0.5 V	00:00:00.000
06/08	13:48:09.236	Int	1	O	74.5 V	00:00:00.520

Detected period

DISPLAY CHANGE ITEM CHANGE **SAVE** HOLD /Clear

Phase & Wiring Measurement

3 Phase 3 Wire Add 3 current (3 wattmeter method)

Measure current of each phase

Measure each line voltage

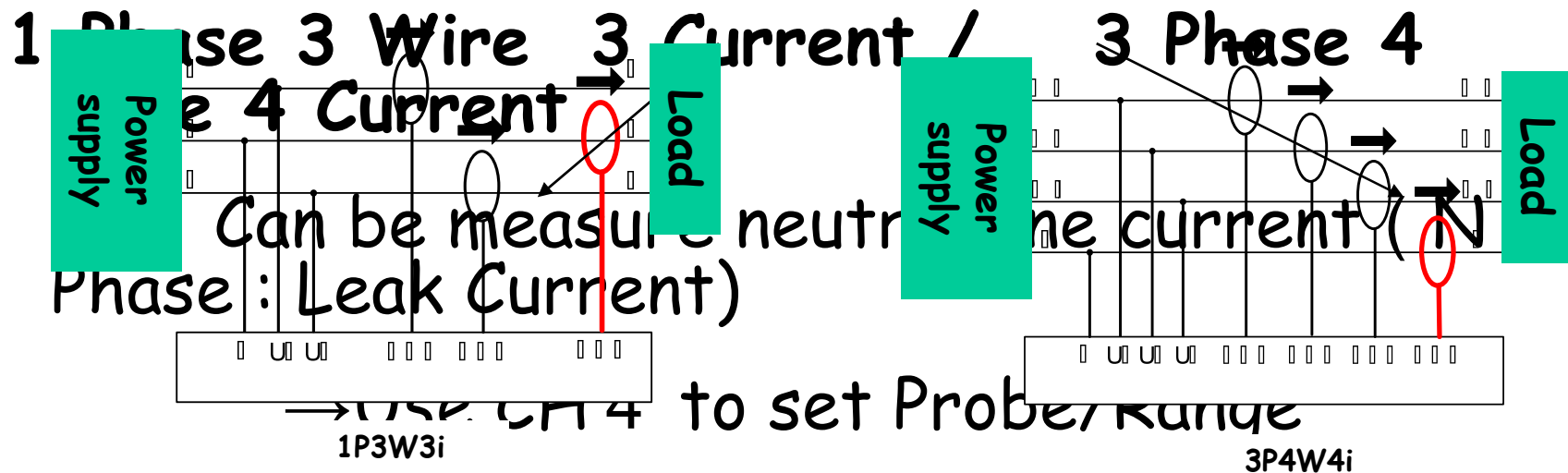

Multi System Measurement

1 Phase 2W X 4 system measurement

- Simultaneous measurement of 1 phase 2W X4 system load

(Common Voltage)

- Clamp probe is settable for each system/Clamp Probe for each system

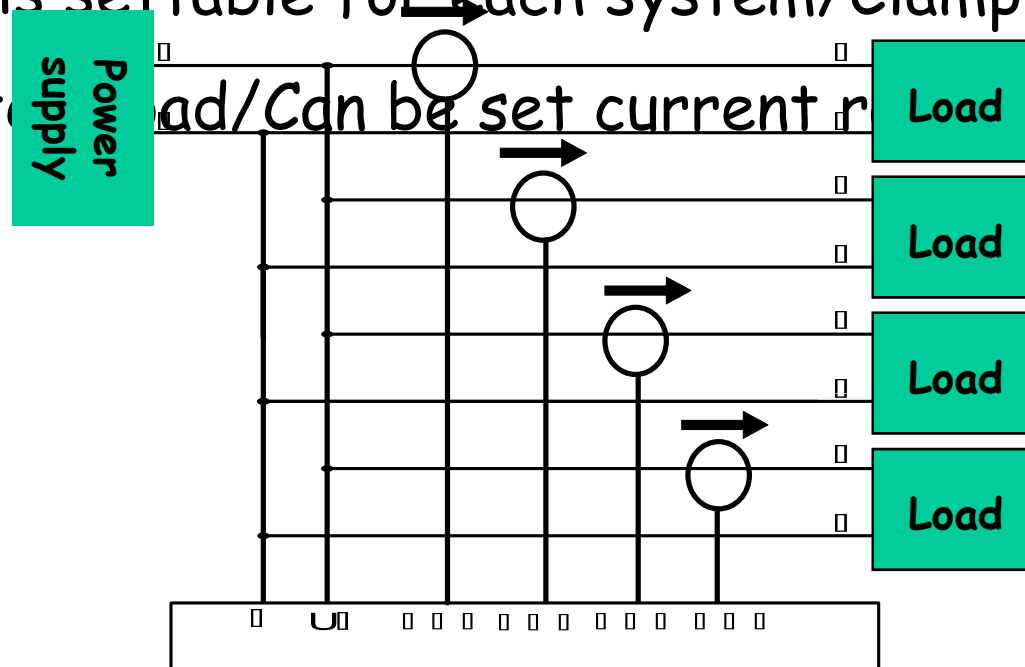

Leak Current Measurement

Leakage current measurement

2A Clamp Probe (96036) new release

200.0mA Range External magnetic field effect is

less than 0.002A

- 1) Leakage current measurement for 1 to 4CH
- 2) When measuring 1 phase 3W3i or 3 phase 4W4i,
- 3) Possible to set Clamp/Range for CH4 (individual)



uses 30031
sensor
technology

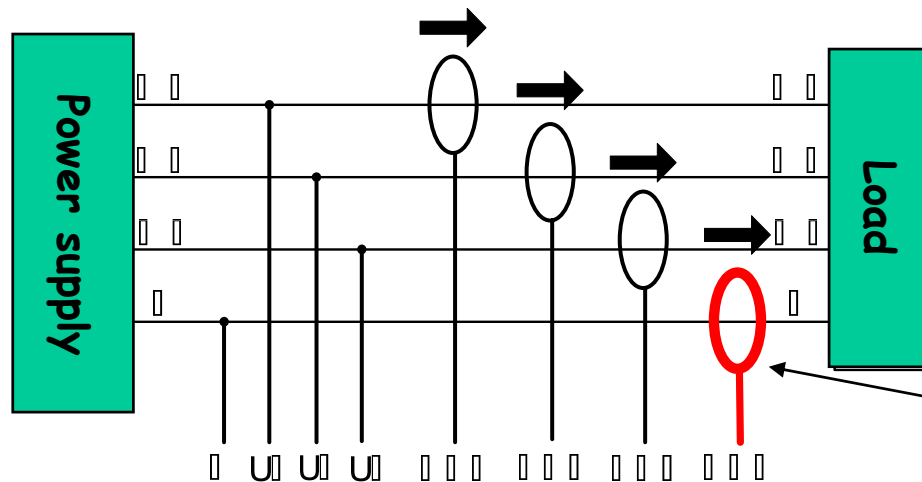

Setting is different
from Ch1 to Ch3

Analog input/output

4CH output + 2CH input

- Analog Output Data can be collected with electric power data

(Range : 100mV/1V/5V)

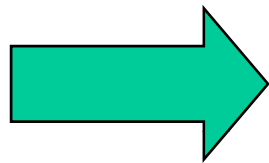

Data from Thermometer/Lux meter which related to power measurement can be collected by CW240

Voltage, Current,
electric power etc.

4ch : $\pm 1\text{VDC}$

Analog Output

Temp/Lux/Flow/Pressure



Wiring & Setting Check

Wiring Check Function

- Check suitability of V/A input value, V/A phase difference, Phase difference between voltage, Phase difference between Current and Frequency

- Wiring Chart, Vector Chart display

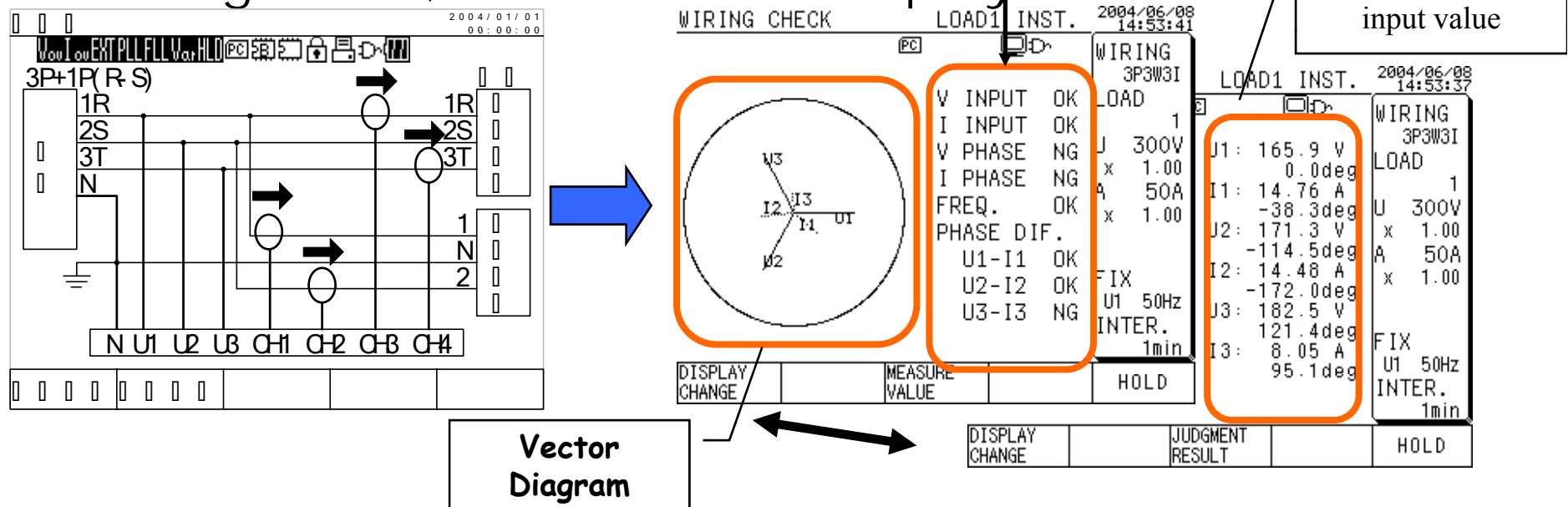

Reduce wiring error before the measurement!

Wiring & Setting Check

Setting Check Function

- Can check setting condition with the display
- If you find mistake, you can go to setting display just by pushing setting button

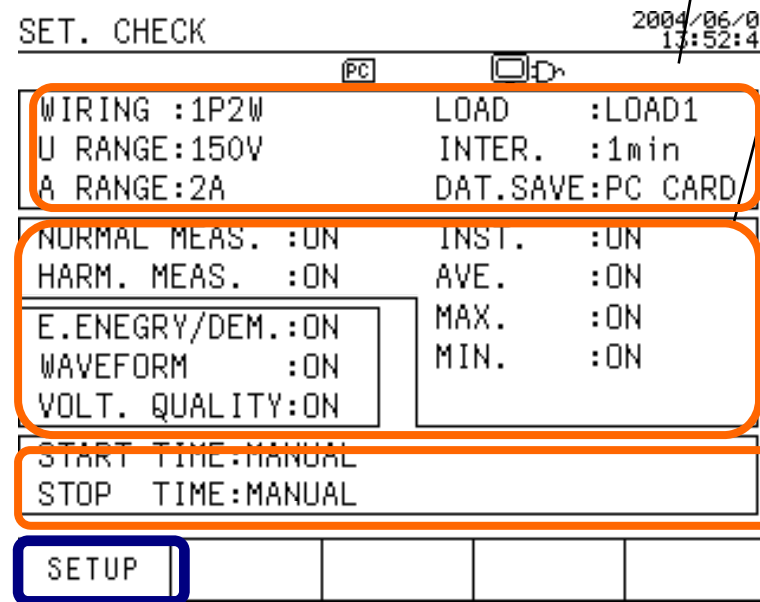

Phase/Range etc.

Saving Item

Start/End Measurement

Prevent measurement failure and wiring error!

■ Good Points of CW240

1. Power Quality (Dip/Swell & 50th Order Harmonics)
2. Leak Current Measurement (No effect from external magnetic field)
3. Analog input/output
4. Commonly used Clamp Probe
5. Vector display of wiring error check
6. Data memory save/Waveform display start from 1 cycle
7. Easy operation

Energy Saving Tool (variable freq)

A Yokogawa Commitment to Industry
vigilance™

YOKOGAWA 



WT210/WT230

ENERGY SAVING

Digital Sampling Power Meters
with Superior Cost Performance

TOOLS

Digital Power Meter

WT210/WT230



YOKOGAWA 

WT210/WT230 Product Position

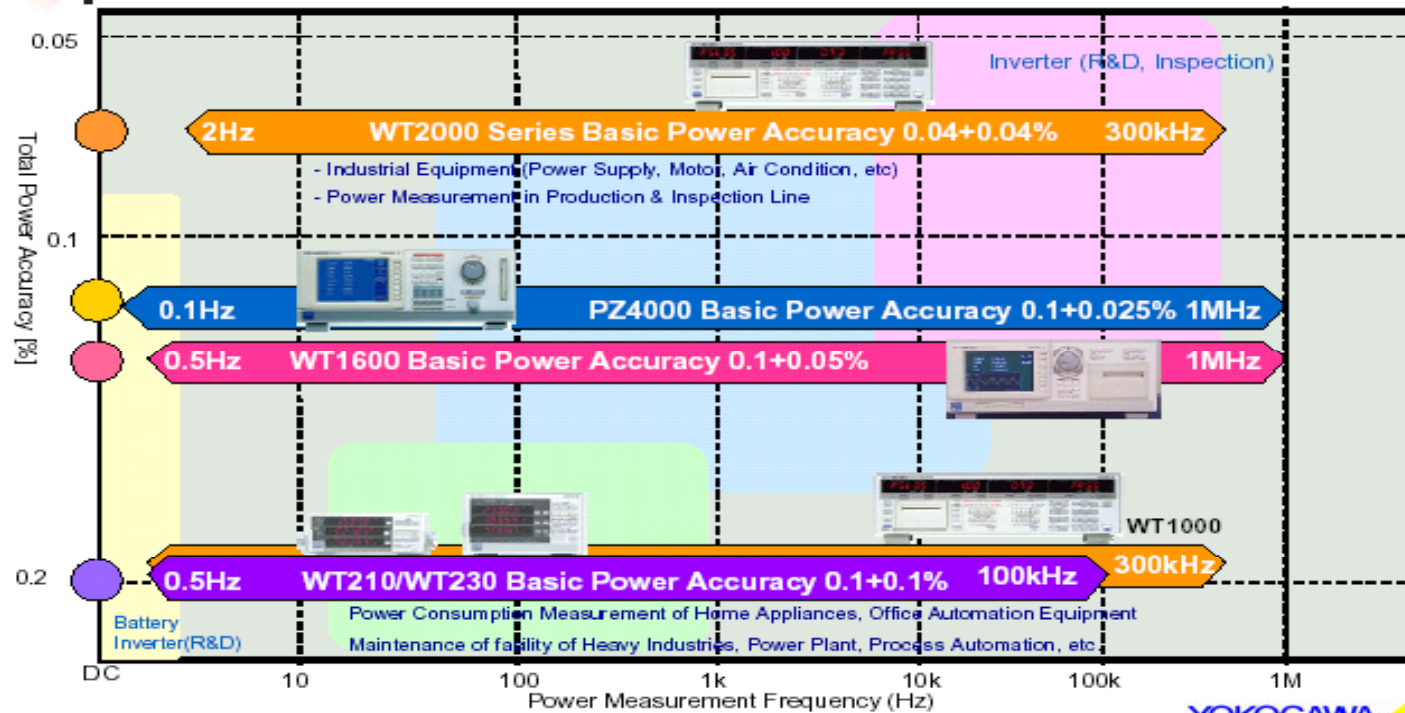



Benefits of Wide Frequency Range & High Accuracy in Power

* Low-frequency measurements starting at **0.5Hz**

Low-Frequency Equipment

- It can be used with evaluations of cycloconverter and when a motor started
- PM-series (Voltech) at 5Hz / LMG450 (ZES Zimmer) at 1Hz

* High Accuracy in Power **0.2%**

Commercial Power Supplies

- 0.1% of rdg + 0.1% of rng is same as WT1000
- PM-series: 0.4% / D4000 (NORMA): 0.3%

* High Frequency Range **100kHz** Inverters

- more precise measurements on high-frequency equipment such as Inverter
- PM-series: 50kHz / LMG450: 20kHz / LMG95: 50kHz / D4000: 100kHz

<Cycloconverter>

Cycloconverter is the equipment which can switch AC Line Frequency to different Output Frequency. Normally the maximum output frequency is limited to approximately 1/3 of the incoming AC line frequency. In another word, it's called as VVVF Inverter (Variable velocity, Variable Frequency).

YOKOGAWA 



Assured Accuracy from 1% of range

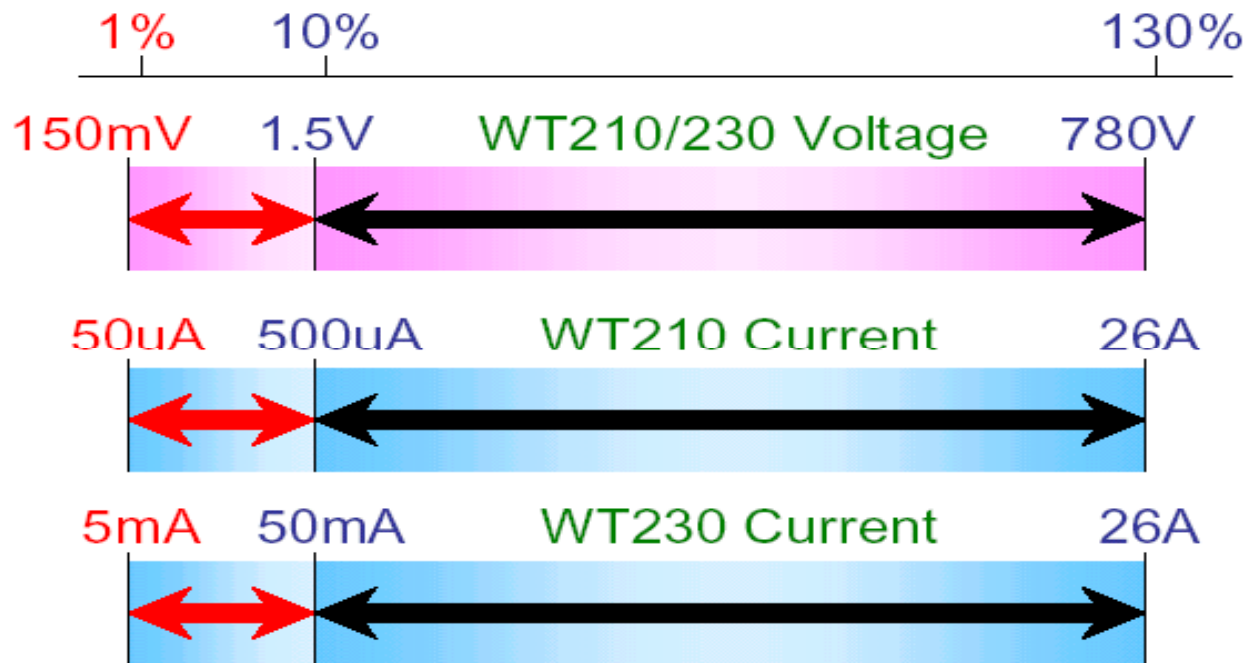



Benefit of assured accuracy from 1% of rng

The power of Intermittent control equipment changes significantly over time. Normally measurement range is set and fixed according to the maximum level of the signals. **Assured accuracy from 1% to 130%** is highly effective for consumed power measurements in such a case.

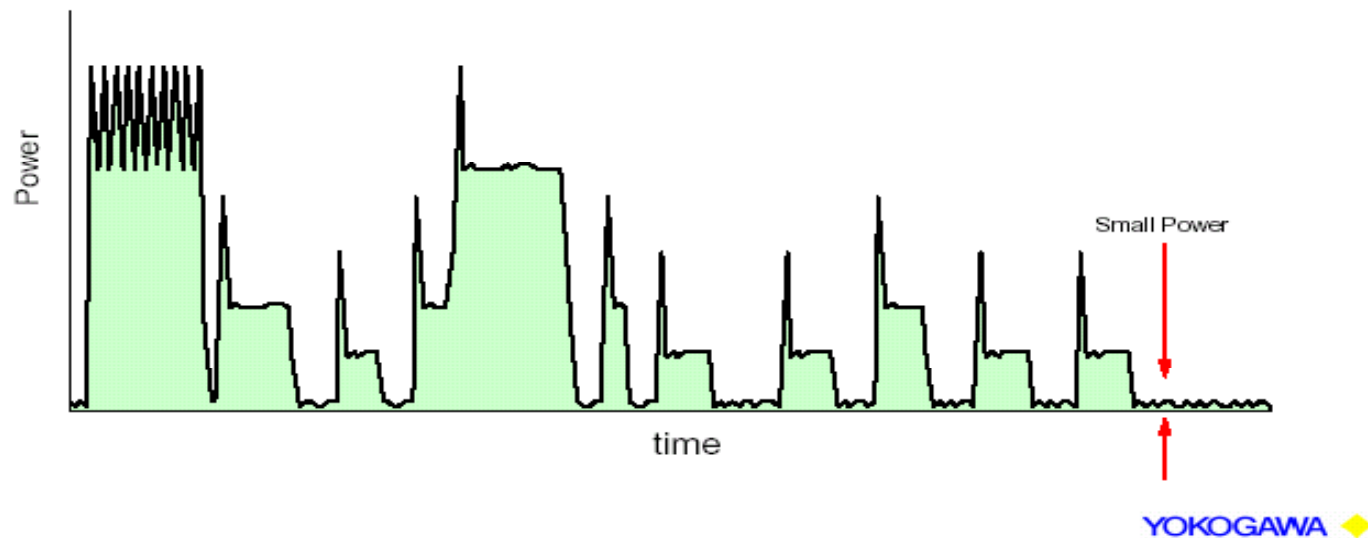



Capture a variety of Signal Types

NEW

Constantly changing Signals

Quick Response with display updating as fast as every 0.1 second

When measurement intervals as short as 0.1s, you can capture transient phenomena with a fine level of detail. You can also reduce the time per measurement for increased throughput in production testing.

NEW

Noisy Signals

Line Filter Function ($f_c=500\text{Hz}$)

The function lets you measure fundamental wave RMS value for inverter output voltage

Surge Current & Maximum load state

MAX hold function for Voltage, Current and Power

This function lets you keep, on the display voltage and current peak values, voltage and current RMS values, and max. values for active power, apparent power, and reactive power.

Half-wave Rectification, Intermittent Control, Distortion waves

Measurement of DC Components

In addition to using DC input, you can obtain precise measurements of signals containing DC components, such as intermittent signals and half-wave rectification signals.

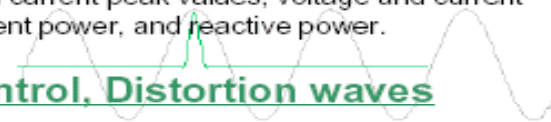

Applications

1. Energy Audits - Viewing Energy Consumption at Factories and Buildings especially cyclo-converters, induction motors, transformers, High Frequency Inverters, High Frequency Lighting etc
2. Power Quality Management
3. Improvement of Harmonic Measurement and Diagnosis
4. Review and Investigation on Contract Demand

Contact

For an insight into the wonderful world of Test, Measuring,
Data Acquisition & Recording Instruments
please click on the following link

www.yokogawa.com/tm

To know more about our Indian operations you may also
visit us at

www.yokogawa.com/in

For any Technical / Commercial Information contact

Mr. Pragnesh Mistry

Phone: 0265 - 2333762 Fax: 0265 - 2330130

Email: baroda@in.yokogawa.com



THANK YOU FOR YOUR ATTENTION