



# ENERGY CONSERVATION BUILDING CODE TIP SHEET



Version 1.0 — February 2008

## BUILDING LIGHTING DESIGN



Credits:

E Source Technology Atlas Series - Lighting  
Energy Efficiency Manual - Donald R. Wulfinghoff  
Alliance to Save Energy

USAID ECO-III Project  
International Resources Group  
Phone: +91-11-2685-3110  
Fax: +91-11-2685-3114  
Email: eco3@irgssa.com

*Lighting is a major energy consumer in commercial buildings. Heat generated from electrical lighting also contributes significantly to the energy needed for cooling of buildings. ECBC prescribes the amount of power for lighting, specifies types of lighting controls, and defines situations where daylighting must be used. This document (primarily adapted from E Source Technology Atlas - Lighting and Energy Efficiency Manual) provides guidance towards the design of ECBC compliant lighting systems in commercial buildings.*

**I**n commercial buildings, lighting typically accounts for 20-40% of total energy consumption. Lighting is an area that offers many energy efficiency opportunities in almost any building, existing as well as new. A typical commercial building has many lighting requirements and each normally has its own set of options for improving lighting efficiency.

Centuries ago, a person could read by the light of a single candle but today a person in a typical office uses hundreds or even thousand times more light. Over

the years, illumination standards have increased radically along with efficiency of lamps (Fig. 1). Modern offices require better illumination, specific activity-oriented lighting provisions, and good visual quality to maximize productivity.

People want light for different reasons, and a good lighting designer must keep them in mind. Different tasks require different amounts and types of light. For example, a surgeon needs lots of light with low glare and excellent color rendering; restaurant owners and diners often want low light levels, warm tones, and a feeling

of intimacy; corporate boardrooms call for lighting that reinforces a feeling of importance and success while adapting to audio-visual presentations; retail outlets in many situations want to make their merchandise sparkle so that it draws the customers and encourages them to buy. An office worker needs modest ambient lighting level, good task lighting on work surface, and minimal glare to effectively read and work on computers. Thus the quality of light in majority of situations is as important as the quantity of light.

While energy efficiency is an attractive goal for many reasons, lighting designers must also consider a host of other factors, including the effect of quality of light on the visual comfort and health of the occupants. Small improvement in lighting quality can improve productivity of the user substantially.

The right quality and quantity of light can be provided efficiently (with less energy) by using the right technology and its effective integration with daylight.

### Daylighting

Sunlight is free and uses no electricity.

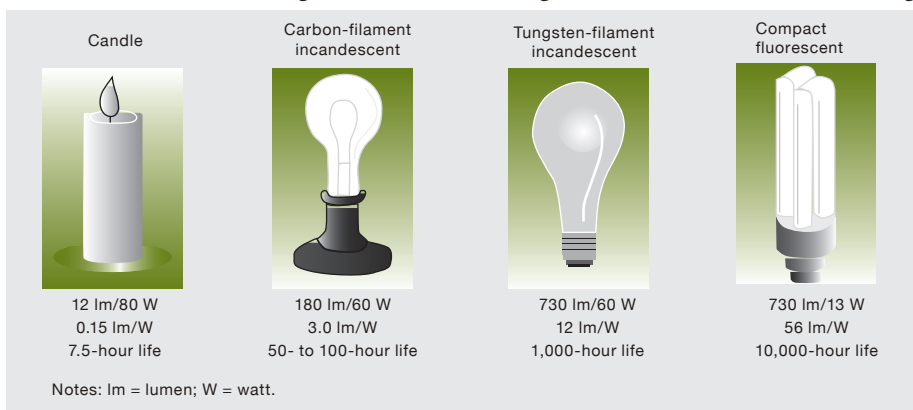
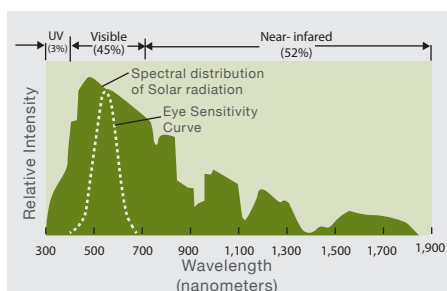

Fig 1: Evolution of Lighting Technologies (Source: E Source Lighting Atlas)



Human beings by nature are accustomed to live and work more comfortably in sunlight. Although our optical sensors (human eye) can only see a very narrow portion of electromagnetic spectrum, they are well adapted to sunlight (Fig. 2). Both economics and the imperatives of health and aesthetics favour the practical use of daylight in the buildings. Simply adding a large number of windows to a building to “let the sun shine in” can create excessive glare, make other spaces look dark by contrast, and admit so much unwanted heat gain due to near infrared radiation that the space could become virtually unusable.



**Fig 2: Solar Spectrum (Source: E Source Lighting Atlas)**

Poorly designed daylight areas can be worse than spaces with no daylight. When done properly, daylighting coupled with energy-efficient glazing and good lighting controls can make new and existing buildings efficient, delightful and healthy. The tools to do it right exist, and are being applied by a growing body of talented lighting designers.

### Interactive Effects of Lighting

Lamps use electricity to produce light. Except for a small percent of energy used in producing light, majority of energy used by interior lights ends up as heat inside the building. In most commercial buildings, lighting is one of the largest sources of internal heat gain. Other sources of internal heat gains are people and equipment in building. Compared to typical lighting, energy-efficient lighting adds less heat to space per unit of light output (Fig. 5). Each kilowatt-hour (kWh) reduction in lighting energy saves 0.4 kWh in cooling energy.

### Lighting Technology

Lighting is one of the fastest developing energy-efficient technologies: energy-efficient T8 and T5 linear fluorescent lamps, linear and compact fluorescent dimming systems, long-life electrode less fluorescent lamp systems, white LEDs,

and PV powered DC lighting systems.

Selection of lamp should be the starting point when deciding how to illuminate a space efficiently. Lamps are also the primary actor in lighting efficiency, and they determine both the electrical and color characteristics of the lighting systems. When a lamp is coupled with its auxiliary equipment (e.g. a ballast or “choke”) and installed in a luminaire (fixture), it becomes the complete light source that is the basic element of the lighting design.

It has long been recognized that an incandescent lamp is much less efficient than fluorescent and High Intensity Discharge (HID) lamp, and that it has smaller operating life. In recent years, further improvements in the efficiency and color characteristics of fluorescent and HID lighting have increased their advantage over incandescent lighting.

### Light Distribution

Though energy-efficient technologies can cut down energy consumption and operating costs, the light path originating from the light source if not properly directed and distributed to the task or activity area through appropriate lamp luminaires (fixtures), could adversely affect the quality of light and reduce energy efficiency gains. Consequently, luminaire selection and design should go together with any energy-efficient lighting strategy.

### Lighting Controls

Controls are the last step in the energy-efficient lighting design process and should be designed after high-efficiency light sources have been chosen. The controllability of light sources varies widely, with low-efficacy incandescent lamps being the easiest to control. Technological developments continue to provide new control capabilities for fluorescent and HID systems.

### Efficient Lighting Design

Optimal lighting solutions can only be reached by considering the integration of daylight, lamps, fixtures, controls, building configurations, interior furnishing, etc. Ideal lighting provides the appropriate level of illumination for the activity with minimum input of energy, with required visual quality. For efficient lighting design, it is often necessary to involve a skilled lighting designer who combines energy efficiency with good quantity and quality of light

needed for the activity and also takes into account several human factors in specifying lighting systems.

### Lighting Design Tools

Lighting software helps designers to compare lighting alternatives and makes sure that the ultimate design choice will provide quality light. Demands on lighting designs are becoming more complex as both lighting quality and energy efficiency have become high priorities. In addition, a wide range of variables—different light sources, fixtures of varying efficiency and photometric, and rooms with a wide range of geometries and surface finishes—all make lighting design a challenge worthy of computer modeling. In particular, the trend among fixture manufacturers to use specular reflectors that send light in particular directions makes modeling more useful than it was with the old-style, white-painted diffuse reflectors. Most computer models can also simulate the effects of daylight and can be used to help designers to develop effective control strategy for getting the optimum blend of electric lighting and daylighting.

Once constructed, a computer lighting model can be easily modified so that various fixture designs and spacings can be evaluated and compared in terms of horizontal and vertical light levels. Designs that give proper quality and quantity of lighting can be evaluated for their energy consumption, and the design that gives both the desired lighting level and the lowest life-cycle cost can be selected. Output from lighting software can also be input into software that models an entire building to enable analysis of the impacts of lighting decisions on other building systems. Lighting professionals who do not first model the design, face the risk of getting poor light distribution or more light than they expect. Both the problems can be difficult and expensive to correct.

### Lamp Technologies

#### Incandescent Lamps

An incandescent lamp consists of a tungsten wire filament that glows and produces visible light when heated to a high temperature. Unfortunately, 90 to 95 % of the power consumed by the hot filament is emitted as infrared (heat) radiation. Although inefficient from an energy standpoint, the luminous

## Key Technical Terms

For implementing the ECBC provisions in lighting system, it is important to understand the following technical terms:

**Astronomical time switch:** An automatic time switch that makes an adjustment for the length of the day as it varies over the year.

**Ballast:** All fluorescent lamps need a ballast to operate. The primary functions of a ballast are to provide cathode heating where necessary, initiate the lamp arc with high-voltage, provide lamp operating power, and then stabilize the arc by limiting the electrical current to the lamp. Secondary functions include input power-quality correction and control features such as lamp dimming or compensation for lumen depreciation.

**Candela:** It is a measure of the intensity (or brightness) of light source in a given direction (Fig. 3).

A 1-candlepower light source delivers a luminous intensity of 1 candela (cd) in all directions. Assuming that the sphere has a radius of 1 foot (ft), the light source will deliver 1 lumen (lm) of light to each square foot (ft<sup>2</sup>) of surface of the sphere, so the illuminance is 1 foot-candle (fc).

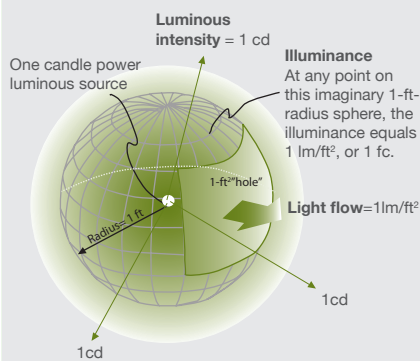

**Fig 3: Relationship of light measurement terms (Source: E Source Lighting Atlas)**

### Color Rendering Index (CRI):

Measured on a scale of 0 to 100. It specifies the color rendition properties of a lamp. The higher the average CRI value, the better the light source. A cool white fluorescent lamp has a CRI of 62 to 70, T8 lamps range from 75 to 98 and standard high-pressure sodium lamps have CRIs of about 27. Lamps with CRIs above 70 are typically used in office and living environments.

### Correlated Color Temperature (CCT):

A measurement on the Kelvin (K) scale that indicates the warmth or coolness of a lamp's color appearance. The higher the color temperature, the cooler or bluer the

light. Typically, a CCT rating below 3200 K is considered warm, while a rating above 4000 K is considered cool.

**Illuminance:** The amount of light that reaches a surface. It is measured in foot candles (lumens/ft<sup>2</sup>) or lux (lumens/m<sup>2</sup>).

**Installed interior lighting power:** The power in watts of all installed general, task, and furniture lighting systems and luminaires.

### Lighting Power Allowance:

(a) Interior lighting power allowance: the maximum lighting power in watts allowed for the interior of a building

(b) Exterior lighting power allowance: the maximum lighting power in watts allowed for the exterior of a building

**Lighting Power Density (LPD):** The lighting power drawn per unit of area of a building type or space. It is usually expressed as watts per square meter or watts per square foot.

**Occupancy Sensor:** A device that detects the presence or absence of people within an area and causes lighting, equipment, or appliances to regulate their operation or function accordingly.

**Reflectance:** The ratio of the light reflected by a surface to the light incident upon it.

**Visible Light Transmittance:** Also known as the Visible Transmittance, is an optical property of a light transmitting material (e.g. window glazing, translucent sheet, etc.) that indicates the amount of visible light transmitted of the total incident light.

**Luminance:** It measures the brightness of a source when viewed from a particular direction. It is expressed in terms of candela/m<sup>2</sup> of the light emitting surface. Luminance describes the intensity of light that is leaving a surface whereas illuminance describes the intensity of light that is falling on a surface. For light reflected from a surface, luminance equals illuminance multiplied by the reflectance of the surface.

**Lumen:** It is the unit of total light output from a light source of a lamp is surrounded by a transparent bubble; total light flow through the bubble is measured

in lumens. Lamps are rated in lumens, which is the total amount of light they emit, not their brightness and not the light level on a surface. Typical indoor lamps have light output ranging from 50 to 10,000 lumens. Lumen value is used for purchasing and comparing lamps and their outputs. Lumen output of a lamp is not related to the light distribution pattern of lamp.

**Lux:** It is the unit of illuminance and indicates the density of light that falls on a surface. One lux equals one lumen per square meter of the surface while one lumen per square foot of the surface is equal to 1 foot-candle. One foot-candle equals 10.76 lux. Average indoor lighting range from 100 to 10,000 lux and average outdoor sunlight is almost 50,000 lux. These lumens and candela are measured by special photometric instruments in laboratories and are used primarily for comparing light sources independent of site conditions. Lux and foot-candles are measured in the field with a meter and may be dependent on site conditions because, unlike candelas or lumens, they are influenced by fixture, room surface reflectance, partitions, and other factors.

**Lamp Efficacy:** Lamp Efficacy is a measure of the output of a lamp in lumens, divided by the power drawn by the lamp. Its units are lumens per watt. Lamp efficacy values are based exclusively on the lamp's performance and do not include ballast losses. Lamp system efficacy values measure the performance of the lamp and ballast combination and this includes the ballast losses.

**Light Luminaire (Fixture):** A light fixture, consists of the ballast, lamp, reflector, in some cases a lens, designed to distribute the light, position and protect the lamps, and connect the lamps to the power supply.

**T#:** As in T5, T8, T12 fluorescent lamps. T stands for tubular; the number describes lamp diameter in one-eighth-inch increments. A T8 lamp is eight-eighths of an inch (or 1 inch) in diameter; a T12 is twelve-eighths of an inch (or 1.5 inches) in diameter.

filament can be made quite small, thus offering excellent opportunities for beam control in a very small package.

### Linear and Compact Fluorescent Lamps (CFLs)

The basic fluorescent lamp contains low pressure mercury vapor and inert gases in a partially evacuated glass tube that are lined with phosphors (Fig. 4). CFLs operate in the same manner as linear fluorescent lamps. The high surface brightness of CFLs requires the use of robust rare earth phosphors, such as those used in modern T8 and T5 linear fluorescent lamps, in order to provide acceptable lumen maintenance.

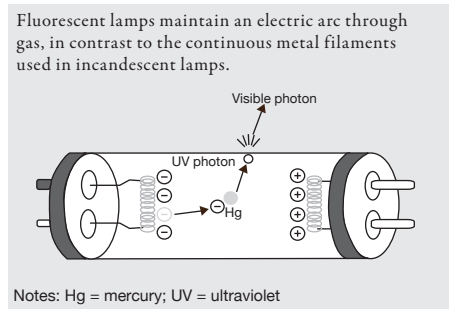
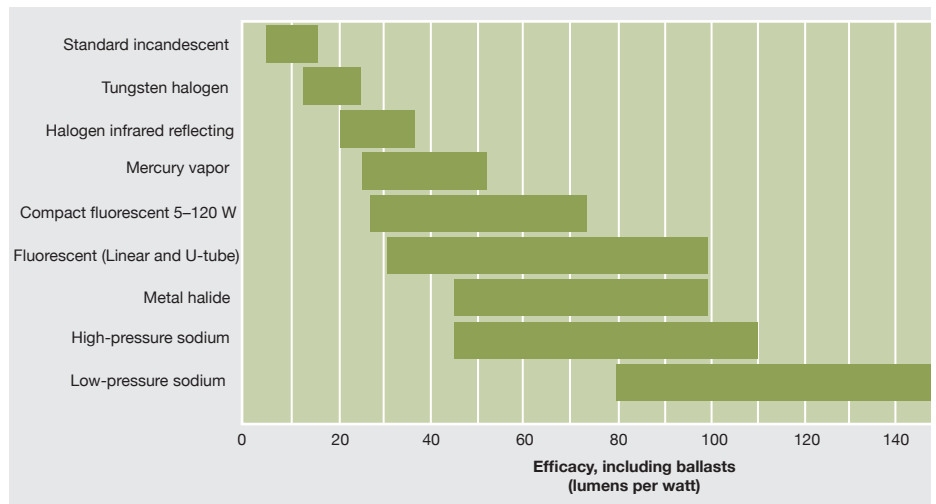

**Fig 4: Fluorescent lamp operation (Source: E Source Lighting Atlas)**

The efficacy (lumens per watt) of fluorescent lamps varies considerably with lamp wattage and ballast type and quality (Fig. 5). The efficacy of a 5-watt CFL on a low-quality magnetic ballast, for example, can be as low as 27 lumens per watt (lm/W). At the other extreme, two 36-watt compact fluorescent lamps powered by a single high-quality electronic ballast deliver nearly 77 lm/W. Typical incandescent lamps operate with an efficacy of 15 to 18 lm/W, so even a low-eficacy CFL is significantly more efficient than the incandescent lamp it might replace.

CFLs have been substituted for an incandescent lamp using the rule of thumb that a CFL uses only 20-25% power to deliver the same light output. However, but many manufacturers' product literature exaggerates CFL performance by "rounding up" when identifying the "equivalent" incandescent lamp. For example, a CFL may be advertised as a replacement for a 75-watt, 1,200-lm incandescent lamp, but it may only produce 1,000 lm. A more accurate description would put the light output of a CFL midway between that of 60W and 75W incandescent lamps.

The effect of CFL on power quality has been debated widely for several



**Fig 5: Relative efficacy of major light sources (Source: E Source Lighting Atlas)**

years. The two primary issues are the Power Factor (PF) and Total Harmonic Distortion (THD) of the ballasts. Typical PF and THD ranges for various ballast types are shown in Table 1. Electronic ballasts, which have come to dominate the market for compact fluorescent lamps (CFLs), are more efficient, weigh less, and are quieter than magnetic ballasts.

Some argue that CFLs are such small loads that their PF and THD should not be of major concern, especially because many other end-use devices on the power grid—personal computers, copiers, laser printers, microwave ovens, televisions, stereos, variable-speed motor controls, and others—also degrade power quality in varying degrees and typically use far more power per unit.

Mercury is an essential ingredient for most energy-efficient lamps. The amount of mercury in a CFL's glass tubing is small, about 4mg. However, every lamp

product containing mercury should be handled with care. Fig. 6 puts mercury pollution from the use of CFLs in a broader context (mercury pollution from thermal power plants generating power).

### High Intensity Discharge Lamps

HID lighting sources are the primary alternative to high-wattage incandescent lamps wherever an intense, concentrated source of light is required. There are three basic types of HID lamps: Mercury Vapor, Metal Halide, and High-Pressure Sodium. Although HID lamps can provide high efficacy, they have special requirements for start-up time, restrike time, safety, and mounting position.

#### a) Mercury-Vapor Lamps

Mercury-vapor (MV) lamps use a high-pressure mercury discharge that directly generates visible light (Fig. 7). Some versions also use a phosphor coating on

**Table 1: Magnetic and Electronic Ballasts Characteristics for CFLs**

Ballast Characteristics	Magnetic	Electronic
CFL base compatibility	Mostly two-pin	Mostly four-pin
Lamp/ballast efficacy	Low	High
Weight	High	Low
Noise level	Slight 120-Hz hum	Very quiet
Cost	Cheaper	Expensive
No. of lamps powered/ballast	1 or 2	1, 2, 3 or 4
Dimmability	No	Available
Universal input voltage	No	Available
Power Factor	0.4 to 0.7 (normal); > 0.9 (better)	0.4 to 0.7 (normal); > 0.9 (better)
Total Harmonic Distortion (%)	6-18 (normal); 15-27 (better)	75-200 (normal); 16-42 (better)

Source: E Source Lighting Atlas

## Environmental Impacts of Mercury Used in Fluorescent Lamps

As energy-efficient lighting becomes more popular, it is important that the lamp products are disposed of in a safe and responsible way. Mercury is released into environment when products with mercury are broken, disposed of improperly, or incinerated.

In spite of the sensational reporting in print and electronic media, the fact is that CFLs present an opportunity to prevent mercury contamination of air, where it most affects the health. One of the major sources of mercury in air comes from burning fossil fuels such as coal, the most common fuel used in India to produce

the inside of the outer bulb to convert the small amount of ultraviolet (UV) light generated by the discharge into additional visible light that improves the color of the lamp. MV lamps have lower efficacy than fluorescent lamps and other HID lamps.

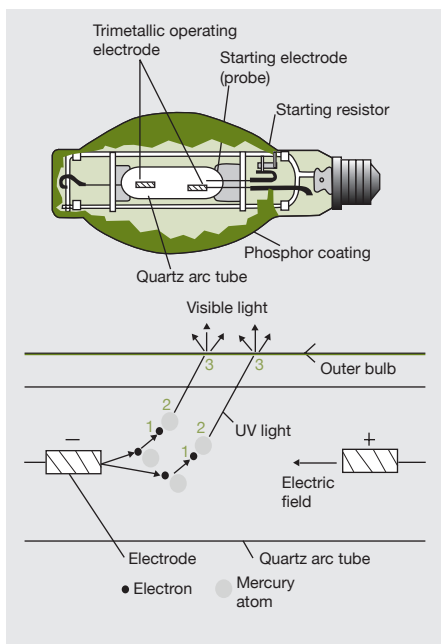
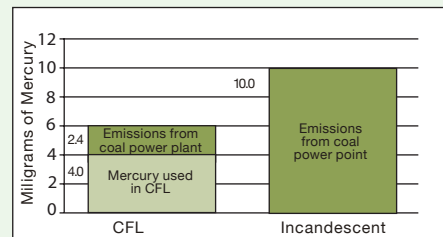

**Fig 7: Mercury Vapor Lamp Schematic (Source: E Source Lighting Atlas)**

### b) Metal-Halide Lamps

Metal-Halide (MH) lamps are similar to MV lamps but feature an important improvement: the addition of iodides of metals such as thallium, indium, and sodium to the arc tube. These metals produce a higher quality and quantity of light than mercury, and the halides form the basis of a regenerative cycle that prevents the metals from depositing on the wall of the arc tube. MH lamps take three to five minutes to reach full output. Restarting after a shutdown or power interruption may require as much

electricity. A CFL uses 75% less energy than an incandescent light bulb and lasts six times longer. A thermal power plant emits 10 mg of mercury to produce the electricity to run an incandescent bulb compared to only 2.4 mg of mercury to run a CFL for the same time.



**Fig 6: Mercury Emissions by Light Source Over Year Life (Source: US EPA, June 2002)**

as 10 to 15 minutes for the arc tube to cool and the mercury and metal-halide gas densities to drop before the arc can be re-struck, plus another three to five minutes to reach full output again. MH lamps produce relatively high levels of UV radiation that can be controlled with shielding glass in the lamp or fixture.

### c) Sodium Lamps

In sodium lamps, a high-frequency, high voltage pulse ionizes a rare gas, typically xenon, in an enclosed tube. The ionized gas in turn vaporizes a sodium-mercury amalgam. An electric arc through this vapor excites sodium atoms, which emit visible light—mostly in the longer wavelengths between yellow and red—when they return to their ground state. For high-pressure lamps, the gas mixture is sealed in a translucent polycrystalline alumina cylinder that transmits 90 percent of the visible light created inside it. Sodium lamps vary widely in their efficacy and color quality, and their performance is very sensitive to the gas pressure inside the arc cylinder. Improving the quality of light from some sodium sources, significantly reduces their efficacy.

### Light-Emitting Diodes

During the past few years, solid-state lighting in general and Light Emitting Diodes (LEDs) in particular have received more attention than any other lighting technology. This high level of interest is based on the demonstrated performance advantages of LEDs in many niche applications, and it is also fueled by LEDs' potential for substantial energy savings in general lighting applications if the technology can meet the performance targets established by

its proponents. LEDs use solid-state electronics to create light. Major elements in the packaging of an LED include a heat sink to dissipate the energy that is not converted into light, a lens to direct the light output, and leads to connect the LED to a circuit. Fig. 8 shows a cross section of an LED fixture.

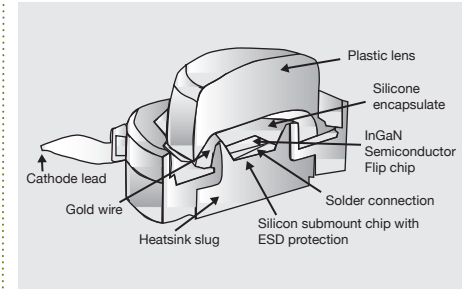

**Fig 8: LED Operation (Source: E Source Lighting Atlas)**

LEDs are increasing in efficacy, light output, and color availability while dropping in cost. High brightness, narrow-band, or various-color LEDs are being used increasingly in vehicle signal lights, traffic signal lights, exit signs, and decorative and information display applications. Composite units of red, green, and blue LEDs, or of systems composed of a blue or violet LED plus a phosphor coating, are being used to create white light further expanding LED applications.

Table 2 shows the comparative characteristics of different light sources.

### Fixture & Reflector

The full potential for energy-efficient lighting comes only through intelligent integration of many system variables. These range from the most minute details of lamp design through the blending of lamps, ballasts, reflectors, lenses, and other components.

It is not enough to select good lamps and other components. However, one must also understand how these components behave in the field. In the lab, fluorescent lamps are typically rated in open-air fixtures at 25°C ambient temperature with a reference ballast that drives the lamp to its full rated output. In the field, however, many ballasts under drive or overdrive lamps. The so-called ballast factor and the temperature of the lamps in field conditions can cause light output to vary by 20 percent or more. Lamp position—whether it is installed base up or base down—can also have a 10 to 20 percent effect on light output from certain sources, such as compact fluorescent lamps.

**Table 2: Comparative Characteristics of Different Light Sources (Source: Energy Efficiency Manual)**

Characteristics	Conventional Incandescent	Halogen Incandescent	Fluorescent Tube Light	Compact Fluorescent
Lumen Output (lumens)	10 to 50,000	300 to 40,000	900 to 12,000	250 to 1,800
Lumen Degradation (% of initial lumens)	15 to 40	8 to 15	8 to 25	15 to 20
Service Life (hours)	750 to 4,000	2,000 to 6,000	7,000 to 20,000	10,000
Efficacy (lumens per watt)	7 to 22	14 to 22	30 to 90	25 to 70, Including ballast losses
Ballast Energy Consumption (percent of lamp wattage)	None	None	5 (high quality electronic ballasts) to 20 (cheap magnetic ballasts)	10 (electronic ballasts) to 20 (magnetic ballasts)
Potential for Lamp Substitution and Mismatch	Unlimited substitution wherever the lamp fits the fixture, provided that fixture heat capacity is adequate.	Unlimited substitution wherever the lamp fits the fixture, provided that fixture heat capacity is adequate.	Limited within narrow ranges of wattage by lamp size, socket style, and ballast compatibility.	Screw-in lamps substitute for each other and for most incandescent lamps, except where they are too large to fit. Cannot be used in dimming fixtures. Other compact lamps have specialized bases that limit substitution.
Color Rendering Index (CRI)	100	100	50 to 95	60 to 85
Effect of Temperature on Light Output	Minimal.	Minimal.	Serious loss of light output above and below optimum lamp temperature (about 38°C).	Serious loss of light output above and below optimum lamp temperature (about 38°C). Lamps that use mercury amalgam maintain light output much better at low temperatures.
Starting Interval	Instantaneous.	Instantaneous.	Instantaneous for lamps with Instant-start ballasts. About one second for rapid-start ballasts. One to several seconds for preheat ballasts.	One to several seconds. Units with mercury amalgam require about one minute to reach full brightness.
Control of Light Distribution	Some styles allow very tight focussing.	Some styles allow very tight focussing.	Allows only loose focussing. Most control perpendicular to lamp axis.	Allows moderately tight focussing, especially with unconventionally large fixtures.
Acoustical Noise	Minimal.	Minimal.	All magnetic ballasts produce some noise, and defective noisy units are fairly common. Some electronic ballasts have noticeable noise.	Good units are quiet, cheap units may be noisy.
Power Factor	No problem.	No problem.	Ballasts with high power factor are available. Some ballasts have low power factor.	Units with high power factor are available. Some have low power factor.
Harmonic Distortion	None.	None.	High distortion occurs primarily in cheaper electronic ballasts.	All units with electronic ballasts have significant harmonic distortion. Cheaper units have much more than others.

Mercury Vapor	Metal Halide	High-Pressure Sodium	Low-Pressure Sodium
1,200 to 60,000	4,000 to 160,000	2,000 to 50,000	1,800 to 35,000
35 to 45	30 to 45	25 to 35	
24,000	5,000 to 20,000	10,000 to 24,000	18,000
35 to 65	70 to 130	50 to 150	100 to 190
8 (large lamps) to 50 (small lamps)	7 (large lamps) to 30 (small lamps)	10 (large lamps) to 35 (small lamps)	ca. 20
Substitutions within type highly limited by ballast compatibility. Some mercury vapor lamps substitute for incandescent lamps without external ballasts, but these offer minimal efficacy advantage.	Substitutions within type highly limited by ballast compatibility.	Substitutions within type highly limited by ballast compatibility. Some HPS lamps are designed as direct substitutes for mercury vapor lamps, offering major efficacy improvement but worse color rendering than other HPS lamps.	Substitutions within type highly limited by ballast compatibility and specialized sockets.
40 to 50	60 to 70	20 to 85	0 to 20
Minimal loss of output above -29°C.	Minimal loss of output above -29°C.	Minimal loss of output above -29°C.	Minimal loss of output above -29°C.
4 to 8 minutes	3 to 10 minutes	5 to 10 minutes	7 to 15 minutes
Allows moderately tight focussing.	Allows moderately tight focussing.	Allows moderately tight focussing.	Allows only loose focussing. Most control perpendicular to lamp axis.
Ballasts are magnetic, and produce some noise.	Ballasts are magnetic, and produce some noise.	Ballasts are magnetic, and produce some noise.	Ballasts are magnetic, and produce some noise.
Ballasts with high power factor are available. Some ballasts have low power factor.	Ballasts with high power factor are available. Some ballasts have low power factor.	Ballasts with high power factor are available. Some ballasts have low power factor.	Ballasts with high power factor are available. Some ballasts have low power factor.
Minor, assuming that the ballasts are magnetic.	Minor, assuming that the ballasts are magnetic.	Minor, assuming that the ballasts are magnetic.	Minor, assuming that the ballasts are magnetic.

## ECBC Compliant Lighting Design Strategy

Many things can go wrong with the building lighting system and well-intentioned attempts to make it energy efficient. Critical missteps to watch out for include:

- Specifying the amount of light for general usage without considering the needs of specific tasks (for example, supplying light for general office work but not addressing the effect of glare on computer screens);
- Designing a daylighting strategy but not enabling the lighting system to dim or turn off when there is sufficient daylight in the interior space;
- Supplying inadequate control of lighting by not allowing lights to be adjusted to specific needs (i.e. turned on in groups or “banks”, or dimmed), and not providing easily accessible control switches;
- Adding a large window area to the façade for daylighting but ignoring the problems of solar heat gain and the need for shading;
- Designing/sizing the building’s HVAC system on rules of thumb and not accounting for the reduction in cooling loads created through efficient lighting system.

### Compliance Approaches - General

ECBC sets mandatory and prescriptive requirements for lighting power density and lighting controls. Compliance with prescriptive requirements can be shown through the Building Area Method or the Space Function Method. In both cases, mandatory lighting requirements are still applicable.

### Mandatory Requirements

**Lighting Control—Astronomical Timers and occupancy sensors** are required to automatically turn lights off in most enclosed interior spaces [ECBC 7.2.1.1]. Control devices also required to override an automatic shutoff control (either manually or through an occupancy sensor) [ECBC 7.2.1.2]. If Daylighting strategy is used in the design, ECBC requires controls that can reduce the light output of luminaires in the daylight space, by at least half [ECBC 7.2.1.3].

There are also control requirements for exterior lighting (with photosensor or time switches) and specialty lighting applications (i.e. displays, hotel rooms, task light-

ing) [ECBC 7.2.1.4 and 7.2.1.5].

Maximum lighting power requirements are also included for exit signs and exterior building grounds lighting [ECBC 7.2.2 and 7.2.3].

As per ECBC, for Exterior Grounds Lighting luminaires greater than 100 Watts shall have a minimum efficacy of 60 Lumens/Watt, unless controlled with a motion sensor. As shown in Fig. 9, luminaires meeting these requirements include fluorescent, mercury vapor and high pressure sodium.

### Prescriptive Requirements

For Interior Lighting Power requirements, [ECBC 7.3], the installed interior lighting power is first calculated to include all lamps, ballasts, current regulators, and controls [ECBC 7.3.3]. Compliance can then be achieved by following the Building Area Method [ECBC 7.3.1] or the Space Function Method [ECBC 7.3.2]. Both methods compare installed lighting power (as proposed) with maximum allowed lighting power densities ( $W/m^2$ ) presented in tables based on either building area type or space function.

### Building Area Method:

**STEP 1:** Determine the allowed lighting power density from Table 7.3.1 of ECBC for each appropriate building area type. Sample LPD values are given in Table 3.

**STEP 2:** Calculate the gross lighted floor area type.

**STEP 3:** The interior lighting power allowance is the sum of the products of the gross lighted floor area of each building area times the allowed LPD for that building area types.

### Space Function Method

**STEP 1:** Determine the appropriate building type from Table 7.3.2 of ECBC and the allowed lighting power density. Sample LPD values are given in Table 3.

**STEP 2:** For each space enclosed by partitions 80% or greater than ceiling height, determine the gross interior floor area by measuring to the center of the partition wall. Include the floor area of balconies or other projections. Retail spaces do not have to comply with the 80% partition height requirements.

**STEP 3:** The lighting power allowance for a space is the product of the gross lighted floor area of the space times the allowed lighting power density for that space. The interior lighting power allowance is the sum of the lighting power allowances for all spaces.

Exterior Lighting Power requirements [ECBC 7.4] require calculating the connected lighting power for building entrances, exits, and facades. These must fall below the power limits listed in ECBC for each lighting application.

### Basic Light Design Concept

When designing or retrofitting the lighting, the general illuminance,

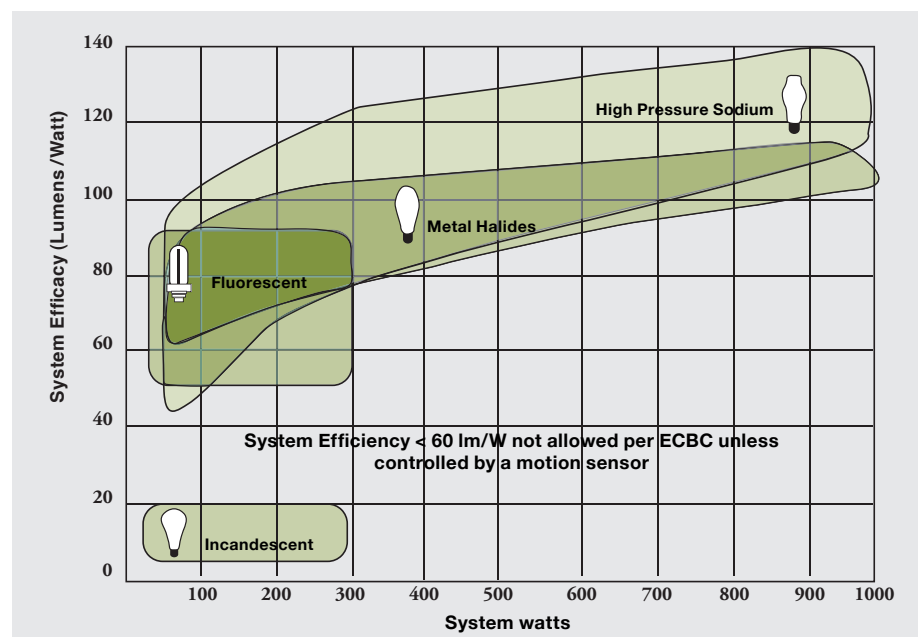

**Fig 9: Exterior Grounds Lighting and specific Technologies (Source: Adapted from ASHRAE/ IESNA Standard 90.1-1999)**

**Table 3: Sample LPD Values (max. permissible) as per ECBC**

Building Area Method	LPD (Watts/m2)	Space Function Method	LPD (Watts/m2)
Office	10.8	Office Enclosed/Open Plan	11.8
Library	14.0	Classroom/Lecture/ Training	15.1
Retail/Mall	16.1	Family Dining	22.6
Cafeteria/ Fast Food	15.1	Hospital (Emergency)	29.1
Parking Garage	3.2	Corridor/Transition	5.4

or amount of light that reaches a surface, can be assessed through manual calculations. The Illuminating Engineering Society of North America (IESNA) has established a procedure for determining how much illuminance is needed for a given task. *The Zonal Cavity or Lumen Method* described below considers several factors to determine type and number of fixtures that would be appropriate to meet the illuminance requirements of the space.

**Zonal Cavity Method:** The basic formula used in this method spring from the definition of illuminance: 1 foot-candle (fc) = 1 lm/ft<sup>2</sup>. That is, to maintain an average of 40 fc in an area of 100 ft<sup>2</sup>, one needs 40 x 100 = 4,000 lm coming out of the fixtures. But several modifying factors must be considered: The fixture is not absolutely efficient in dispensing light; much of that light may be lost while being reflected off of various surfaces before it arrives at the work surface. Also, light sources degrade with age and dirt buildup.

To complete the zonal cavity calculation, three fundamental quantities must be known: the Room Cavity Ratio (RCR), the Coefficient of Utilization (CU), and the Light Loss Factors (LLF).

**Room Cavity Ratio:** Room Cavity Ratio (RCR) characterizes a room by shape and is calculated using the formula below, using the room dimensions and light fixture distance over the working desk. Refer Figure 10, for the calculation shown below:

$$RCR = \frac{5(H)(L+W)}{L \times W} = \frac{5(10-2.5-1.5)(20+10)}{20 \times 10} = 4.5$$

**Coefficient of Utilization:** CU is a measure of the fixture’s ability to distribute light down to the work plane using the RCR value and the

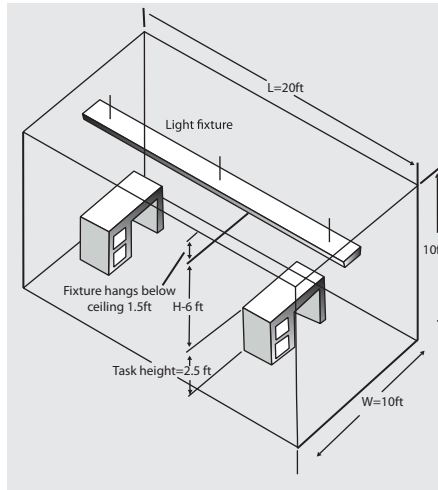

**Fig 10: Room Dimensions and Fixture Location (Source: E Source Lighting Atlas)**

surface reflectance of the walls, floor, and ceiling. Fixture efficiency is the proportion of lamp light that escapes the fixture at any angle, whereas CU is the proportion of lamp light that reaches the work plane. The two are calculated differently and are not interchangeable. All else being equal, a fixture in a room with a low RCR will have a higher coefficient of utilization than if it were in a room with a high RCR. CU values are given by the fixture manufacturer.

Table 4 shows how rapidly the CU value drops as wall reflectance decreases or as RCR increases.

**Table 4: Typical Coefficient of Utilization (CU) Values**

Room Cavity Ratio (RCR)	Reflectance (Wall)	50		30		10	
		80	50	80	50	80	50
1	80	67	56	65	53	53	51
2	80	66	54	63	51	51	49
3	80	65	52	61	50	50	48
4	80	64	50	59	48	48	46
5	80	63	48	57	46	46	44
6	80	61	46	53	44	44	42
7	80	59	43	51	42	42	40
8	80	56	41	49	40	40	38
9	80	54	40	47	38	38	36
10	80	51	39	45	36	36	34

**Light Loss Factor:** Light distribution is not only affected by the color and reflectance of room surfaces and furnishings but also by change in lighting output over time, which is principally a function of lamp lumen depreciation and fixture dirt buildup. Lumen depreciation data can be found in technical information supplied by the lamp manufacturer, and dirt depreciation values can be taken from graphs (IESNA) for various types of fixtures and dirt environments.

Once these Light Loss Factors have been taken into account, one has a more realistic picture of the “maintained foot-candle level.” The number of lamps (or fixtures) needed to attain that sustained minimum light level over a lamp’s lifetime can then be determined by the zonal cavity formula:

The lumen method or zonal cavity calculation is a quick and simple technique for predicting the average illuminance level in a room. The calculations have simple input requirements:

1. Physical characteristics of the room, including length, width and height;
2. Ceiling, wall and floor reflection (% of light reflected by the room surfaces);
3. Work plane height;
4. Distance from the work plane to luminaries
5. Coefficient of Utilization (CU) for the luminaries.
6. Number of lamps per luminaire and initial lumen output of each lamp
7. Light Loss Factors (LLFs)

The method can be used to calculate the average illuminance incident on the work plane once the lighting system has been designed.

This method is heavily dependent on several assumptions: that surface reflectances are reasonably accurate, the fixtures are evenly distributed in the room; and other concerns such as voltage, room temperature, fixture temperature, and ballast factor are normal and will not affect lamp lumen output. The basic RCR calculation assumes that the fixtures are mounted on the ceiling; variations in the RCR calculation method can account for direct/indirect fixtures mounted on pendants.

Fixtures that cause less glare are deeper (to conceal the lamp) and have lower CU values, meaning more light will be needed to attain a given foot-candle level. More watts will also be needed, so care is essen-

tial in weighing the need to avoid/reduce glare in upgrade situation.

The above discussion pertains to cases involving uniform light levels. In some cases, non-uniform levels are better, even if existing levels are uniform. This typically occurs in merchandising, where one would want products to stand out.

### Tips for Energy Efficient Lighting

Any lighting system generates heat that needs to be dissipated. By designing an energy efficient lighting system that integrates daylighting and good controls, heat gains can be reduced significantly. This can reduce the size of the HVAC system resulting in first-cost savings.

### Daylighting Tips

Daylighting benefits go beyond energy savings and power reduction. Daylight spaces have been shown to improve people's ability to perform visual tasks, increase productivity and reduce absenteeism and illness. Building fenestration should be designed to optimize daylighting and reduce the need for electric lighting. Following tips can help in designing an integrated lighting system:

#### Coordinate with design of electric lights;

- Plan the layout of interior spaces—use the layout to allow daylight to penetrate far into the building (Fig. 11).
- Orient the building to minimize building exposure to the east and west and maximize glazing on the south and north exposures.
- Follow ECBC Visible Light Transmittance (VLT) requirements [ECBC 4.3.3.1] for windows—to maximize light and visual quality.

Effective daylighting strategy should include a combination of the following:

#### Address interior color schemes;

Interior surfaces, and especially the ceiling, must be light colored. Consider light colored furniture and room partitions to optimize light reflectance. Avoid furniture colors and placement that will interfere with light distribution. Keep ceilings and walls as bright as possible.

#### Avoid glare

Inability to control glare is the most

The schematic shows a mix of top-lighting, side-lighting, light shelves, high reflectance ceilings and wall diffusion to provide fairly uniform deep-plan daylighting without the glare of direct sunlight.

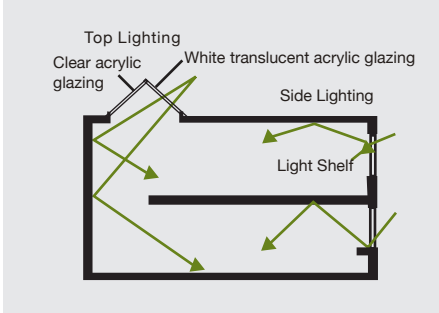

Fig 11: Simple daylighting Techniques (Source: E Source Lighting Atlas)

common failure in incorporating daylighting and especially important where computer use is extensive. Best practice glare control includes the use of adjustable blinds, interior light shelves, fixed translucent exterior shading devices, interior and exterior fins, and louvers.

#### Control

Daylight strategies do not save energy unless electric lights are turned off or dimmed appropriately. ECBC requires controls in daylit areas that are capable of reducing the light output from luminaires by at least half. It is important to have properly functioning controls that are placed in appropriate locations and are calibrated to provide a consistent level of lighting. Good lighting design is critical for an energy-efficient and comfortable building.

- Install effective placards at lighting controls;
- Install dimmers to take advantage of daylighting and where cost-effective;
- Replace rheostat dimmers with efficient electronic dimmers;
- Combine time switching with daylighting using astronomical timeclocks;
- Control exterior lighting with photo-controls where lighting can be turned off after a fixed interval.

#### Design Tips

Many offices that were designed to handle typing and similar horizontal office tasks earlier are now filled with desktop computers and workstations (often having reflective surfaces), which require careful consideration of both horizontal and vertical illumination in the offices.

- Deal with each activity area and each fixture individually;

- Eliminate excessive lighting by reducing the total lamp wattage in each activity area;
- Lighting layout should use task lighting principle. Install focussing lamps or flexible extensions wherever needed;
- Plan for future changes in activities and space layout. Install fixtures and combinations of fixtures that provide efficient lighting for all modes of space usage.
- While selecting recessed lighting fixtures, one must evaluate the reduction in lamp life as a result of higher junction temperature (Fig. 12).

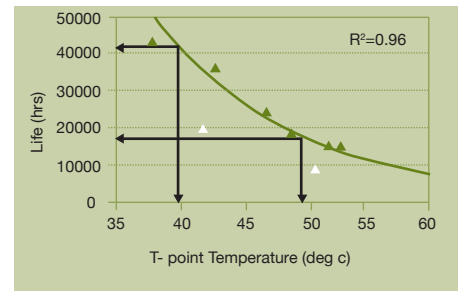

Fig 12: Effect of Junction Temperature on Life of LED Lamp (Source: Lighting Research Institute)

#### Simulation Tips in Lighting Design

Simulation using a variety of computer software tools is not only the way a design professional or team determines compliance with the ECBC, but it may be the best method for guiding a design using a system-based approach. Lighting software helps users compare lighting alternatives and make sure that the ultimate design choice will provide quality light. A wide range of variables—different light sources, fixtures of varying efficiency and photometric, daylighting, and rooms with a wide range of geometries and surface finishes—all make lighting design a challenge worthy of computer modeling.

In order to be useful, the most sophisticated software tools require training and experience on the part of the user, but numerous simpler programs are also available for the designer who does not need all the functionality of the most complex products. A number of lighting software tools are also available free of charge. They come from government agencies and private companies, and they offer a wide range of capabilities. More information about lighting software is available from the Building Energy Software Tools Directory maintained on the U.S. Department of Energy Web site. In addition, The Illuminating Engineering Society of North America

periodically conducts a survey of lighting software tools and publishes the results in its magazine *Lighting Design and Application (LD+A)*.

Table 5 provides an overview of lighting design tools used by the lighting professionals.

### Lighting Retrofit Tips

- Replace incandescent and other inefficient lamps with lamps with higher lighting efficacy;

- Eliminate excessive lighting; disconnect the ballast or remove the fixture where they are not needed;
- Replace ballasts with high efficiency or reduced wattage types, or upgrade ballasts and lamp together;
- Relocate or reorient fixtures to improve visual quality;

- Modify existing fixtures to reduce/eliminate light trapping and/or improve light distribution. In fixtures having shades that absorb light, modify or eliminate the shade;

### Maintenance Tips

There are important considerations that need to be made to optimize a design for energy efficiency in lighting: reduction

**Table 5: Commonly Used Lighting Design Software**

Software	Description	Contact Information
AGI32	Lighting calculation and visualization program. Latest release, 1.7, adds daylight factor calculations, unified glare-rating calculations for discomfort glare in interiors. Company also offers a simplified version, AGI-Light.	Lighting Analysts Inc. Littleton, Colorado, USA Phone: +1-303-972-8852 E-mail: info@agi32.com URL: www.lightinganalystsinc.com
Autodesk VIZ	Three-dimensional modeling, rendering, and presentation capabilities. Includes daylighting calculations.	Autodesk Inc. San Rafael, California, USA Phone: +1-800-440-4198 URL: www.autodesk.com
Building Design Advisor	A data manager and process controller that allows building designers to use several analysis and visualization tools throughout the building design process. The current version includes links to a simplified Daylighting Computation Module (DCM), a simplified Electric lighting Computation Module (ECM), and the DOE-2.1E Building Energy Simulation software.	Konstantinos Papamichael Lawrence Berkeley National Laboratory Berkeley, California Phone: +1-510-486-6854 E-mail: k_papamichael@lbl.gov URL: http://gaia.lbl.gov/
DAYSIM	Daylighting analysis software that predicts the annual daylight availability and electric lighting use in buildings that use manual and automated lighting and blind controls. Based on Radiance software and available for free.	Christoph Reinhart National Research Council Canada Institute for Research in Construction Ottawa, Ontario Canada Phone: +1-613-993-9703 E-mail christoph.reinhart@nrc-cnrc.ca URL: www.daysim.com
DIALux	Lighting calculations and modeling from DIAL, a European lighting services organization that is supported by manufacturers. Useful for simple calculations and available for free.	DIAL GmbH Lüdenscheid Germany Phone: +49-0-2351-10-64-360 E-mail: dialog@dial.de URL: www.dial.de
LITE-PRO	Lighting design tool from Hubbell Lighting Co. Includes indoor and outdoor lighting capabilities and rendering.	Columbia Lighting, Spokane, Washington, USA Phone: +1-509-924-7000 E-mail lvigue@columbialighting.com URL: www.columbialighting.com/litepro/features.htm
Lumen Designer	The latest upgrade of the popular Lumen Micro product. Adds internal modeling and daylighting capabilities. A highly interactive interface features a Design Wizard for setting up complex projects. Product also includes plug-ins for roadway lighting and advanced rendering. Company offers a simplified version: Simply Lighting 2002.	Lighting Technologies Inc. Denver, Colorado, USA Phone: +1-720-891-0030 URL: www.lighting-technologies.com
ProjectKalc	Helps the user compare the energy and operating cost impacts of alternative lighting upgrade solutions. It can handle lighting upgrades involving controls, relamping, delamping, tandem wiring, and more. It includes user-modifiable databases of costs, labor time, and performance for over 8,000 common hardware applications. The software is available free of charge through the U.S. Environmental Protection Agency (EPA) Energy Star program.	EPA Energy Star Program, Washington, D.C., USA URL: www.energystar.gov/index.cfm?c=business.bus_projectkalc
Radiance	An advanced lighting simulation and rendering package that calculates spectral radiance values and spectral irradiance for interior and exterior spaces considering electric lighting, daylight, and inter reflection. Used by architects and designers to predict illumination, visual quality, and appearance of design spaces. Used by researchers to evaluate new lighting and daylighting technologies and study visual comfort and similar qualities related to the visual environment. It is available for free. There is a project underway to develop a nice interface to this extremely powerful application to improve its usability.	Charles Ehrlich Lawrence Berkeley National Laboratory Berkeley, California, USA Phone: 510-486-7916 E-mail: ckehrlich@lbl.gov URL: http://radsite.lbl.gov/radiance/HOME.htmlFree
Visual	Lighting analysis software for interior and exterior applications. Integrates an advanced 3-D modeling environment with an intuitive interface. Professional presentation capabilities enable user to quickly develop, analyze, and modify advanced lighting designs. Basic version is available free of charge.	Acuity Brands Lighting Visual Support Center, Conyers, Georgia, USA Phone: 800-279-8043 E-mail: support@visuallightingsoftware.com URL: www.visuallightsoftware.com

in first costs, reduced operation and maintenance, and increased occupant productivity and comfort. Consider the following:

- Good lighting also effects the operation and maintenance of a building. A simpler and easy to control lighting system will lower the “first cost” of the system.
- Fluorescent lamps last an average of 10 times longer than incandescent and reduce re-lamping labor costs.
- Clean fixtures and lamps at appropriate intervals to maintain optimum lighting output.

### Lighting Controls Tips

Purpose of Lighting Controls: In many applications, the overall purpose of the lighting control system is to eliminate waste while providing a productive visual environment. This may entail:

1. providing the right amount of light;
2. providing light where it’s needed.

A few issues to keep in mind while designing controls are:

- Install a separate control circuit for each lighting element that operates on a distinct schedule;
- Where light fixtures are needed in a predictable variety of patterns, install programmable switches;
- Install lighting controls at visible, accessible locations;
- Where lighting is needed on a repetitive schedule, use timeclock control;
- Install occupancy sensors in bathrooms, conference rooms, and other spaces not in constant use.

Controls, switches, shades, timers, and other lighting strategies can get complicated. It is likely that adjustments will occur after occupancy. The easier the lighting system is to understand and adjust to accommodate the occupants and building function, the less likely it is that sensors will be disabled, disconnected, or bypassed. The following provides a strategy for selecting the right controls for your building.

### Define Application Goals

The first step in determining the right control strategy is to thoroughly define and understand the application goals.

Lighting designers should be asked to provide iso-lux charts which discuss the illumination level in the space (Fig. 12).

### Switching or Dimming

The first primary decision after defining the load and the application goals is whether to switch or dim the load.

Switching and dimming are stand-alone strategies but are often used in the same facility, and may be integrated in the same control system. Dimming capability should always be incorporated into areas where daylighting is the primary lighting approach. When using photo sensors in a dimming strategy, it is important to properly commission and calibrate it. Failure to do so can sometimes result in more energy use.

### Degree of Automation Needed

It is worthwhile to determine the amount of local vs. central control that is needed from the lighting control system. Manual lighting controls range from a single switch to a bank of switches and dimmers that are actuated by toggles, rotary knobs, push buttons, remote control, and other means. Manual controls can be cost-effective options for small-scale situations. However, as the lighting system grows, automated

systems become more cost-effective and are better at controlling light. Manual controls often waste energy because the decision to shut off the lights when they are not needed is based entirely on human initiative.

### References:

#### Book References:

1. E Source (2005): E Source Technology Atlas Series - Volume I: Lighting, Boulder, CO, USA
2. Energy Efficiency Manual, by Donald R. Wulfingoff, Energy Institute Press.
3. Energy Conservation Building Code, Ministry of Power, May 2007.

#### Web References:

1. Illuminating Engineering Society of North America (IESNA), <http://www.iesna.org>
2. Advanced Buildings: Technologies and Practices, <http://www.advancedbuildings.org/>
3. The Lighting Research Center at Rensselaer Polytechnic Institute, <http://www.lrc.rpi.edu/>
4. Heshong-Maone Group <http://www.h-m-g.com/>
5. The New Buildings Institute, <http://www.newbuildings.org/lighting.htm>
6. Windows and Daylighting, Lawrence Berkeley National Laboratory, <http://windows.lbl.gov/>

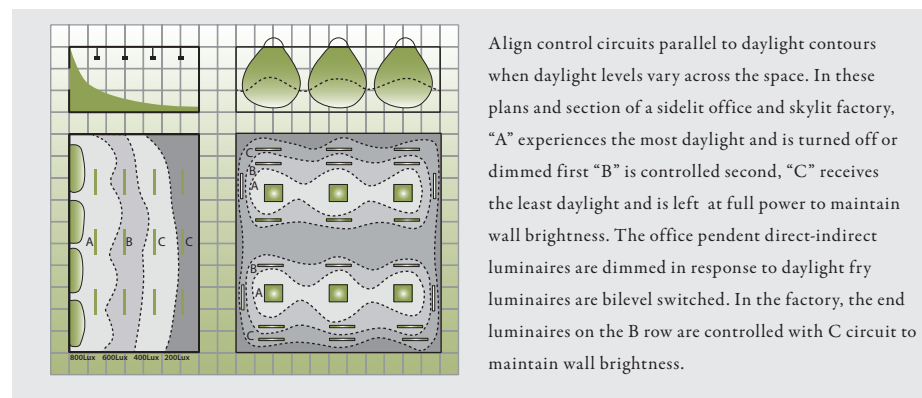

Align control circuits parallel to daylight contours when daylight levels vary across the space. In these plans and section of a sidelit office and skylit factory, “A” experiences the most daylight and is turned off or dimmed first “B” is controlled second, “C” receives the least daylight and is left at full power to maintain wall brightness. The office pendant direct-indirect luminaires are dimmed in response to daylight fry luminaires are bilevel switched. In the factory, the end luminaires on the B row are controlled with C circuit to maintain wall brightness.

Fig. 12: Plan Views of Daylight Isolux Contours (Source: Advanced Lighting Guidelines, New Buildings Institute)



For more information:  
 Dr. Ajay Mathur, BEE ([dg-bee@nic.in](mailto:dg-bee@nic.in))  
 Dr. Archana Walia, USAID ([awalia@usaid.gov](mailto:awalia@usaid.gov))  
 Dr. Satish Kumar, IRG ([skumar@irg ltd.com](mailto:skumar@irg ltd.com))

USAID ECO-III Project  
 Phone: +91-11-2685-3110  
 Email: [eco3@irgssa.com](mailto:eco3@irgssa.com)  
 Web Site: [www.eco3.org](http://www.eco3.org)